

# EC axial fan

sickle-shaped blades (S series)

with guard grille for full nozzle

S3G910-KH02-51 ebmpapst Datasheet

sales@fansco.com

www.fansco.com

Limited partnership · Headquarters Mulfingen

Amtsgericht (court of registration) Stuttgart · HRA 590344

General partner Elektrobau Mulfingen GmbH · Headquarters Mulfingen

Amtsgericht (court of registration) Stuttgart · HRB 590142

## Nominal data

Type	S3G910-KH02-51	
Motor	M3G112-IA	
Phase		3~
Nominal voltage	VAC	400
Nominal voltage range	VAC	380 .. 480
Frequency	Hz	50/60
Method of obtaining data		ml
Speed (rpm)	min <sup>-1</sup>	610
Power consumption	W	630
Current draw	A	1.0
Max. back pressure	Pa	75
Max. back pressure	in. wg	0.3
Min. ambient temperature	°C	-25
Max. ambient temperature	°C	60

ml = Max. load · me = Max. efficiency · fa = Free air · cs = Customer specification · ce = Customer equipment  
Subject to change

## Data according to Commission Regulation (EU) 327/2011 (EN 17166)

		Actual	Req. 2015			
01 Overall efficiency $\eta_{es}$	%	52.4	32.3	09 Power consumption $P_{ed}$	kW	0.6
02 Measurement category		A		09 Air flow $q_v$	m <sup>3</sup> /h	14740
03 Efficiency category		Static		09 Pressure increase $p_{fs}$	Pa	73
04 Efficiency grade N		60.1	40	10 Speed (rpm) n	min <sup>-1</sup>	615
05 Variable speed drive		Yes		11 Specific ratio*		1.00

Data obtained at optimum efficiency level.

The ErP data is determined using a motor-impeller combination in a standardized measurement setup.

\* Specific ratio =  $1 + p_s / 100\,000\text{ Pa}$

LU-185921



## Technical description

Weight	20 kg
Size	910 mm
Motor size	112
Rotor surface	Painted black
Terminal box material	PP plastic
Electronics housing material	Die-cast aluminum, painted black
Blade material	PP plastic
Guard grille material	Steel, coated with black plastic (RAL 9005)
Blade pitch	0°
Airflow direction	V
Direction of rotation	Clockwise, viewed toward rotor
Degree of protection	IP55
Insulation class	"F"
Moisture (F) / Environmental (H) protection class	H2
Max. permitted ambient temp. for motor (transport/storage)	+80 °C
Min. permitted ambient temp. for motor (transport/storage)	-40 °C
Installation position	Shaft horizontal or rotor on bottom; rotor on top on request
Condensation drainage holes	On rotor side
Mode	S1
Motor bearing	Ball bearing
Technical features	<ul style="list-style-type: none"> <li>- Output 10 VDC, max. 10 mA</li> <li>- Operation and alarm display</li> <li>- External 24 V input (parameter setting)</li> <li>- Alarm relay</li> <li>- Integrated PID controller</li> <li>- Motor current limitation</li> <li>- PFC, passive</li> <li>- RS-485 MODBUS-RTU</li> <li>- Soft start</li> <li>- EEPROM write cycles: 100,000 maximum</li> <li>- Control input 0-10 VDC / PWM</li> <li>- Control interface with SELV potential safely disconnected from the mains</li> <li>- Thermal overload protection for electronics/motor</li> <li>- Line undervoltage / phase failure detection</li> </ul>
Touch current according to IEC 60990 (measuring circuit Fig. 4, TN system)	<= 3.5 mA
Electrical hookup	Terminal box
Motor protection	Thermal overload protector (TOP) internally connected
Protection class	I (with customer connection of protective earth)
Conformity with standards	EN 61800-5-1; CE
Approval	CSA C22.2 No. 77 + CAN/CSA-E60730-1; CCC; UL 1004-7 + 60730-1; EAC
Comment	Conformity with standard EN 60335-1 on request

# EC axial fan

sickle-shaped blades (S series)  
with guard grille for full nozzle

## Product drawing

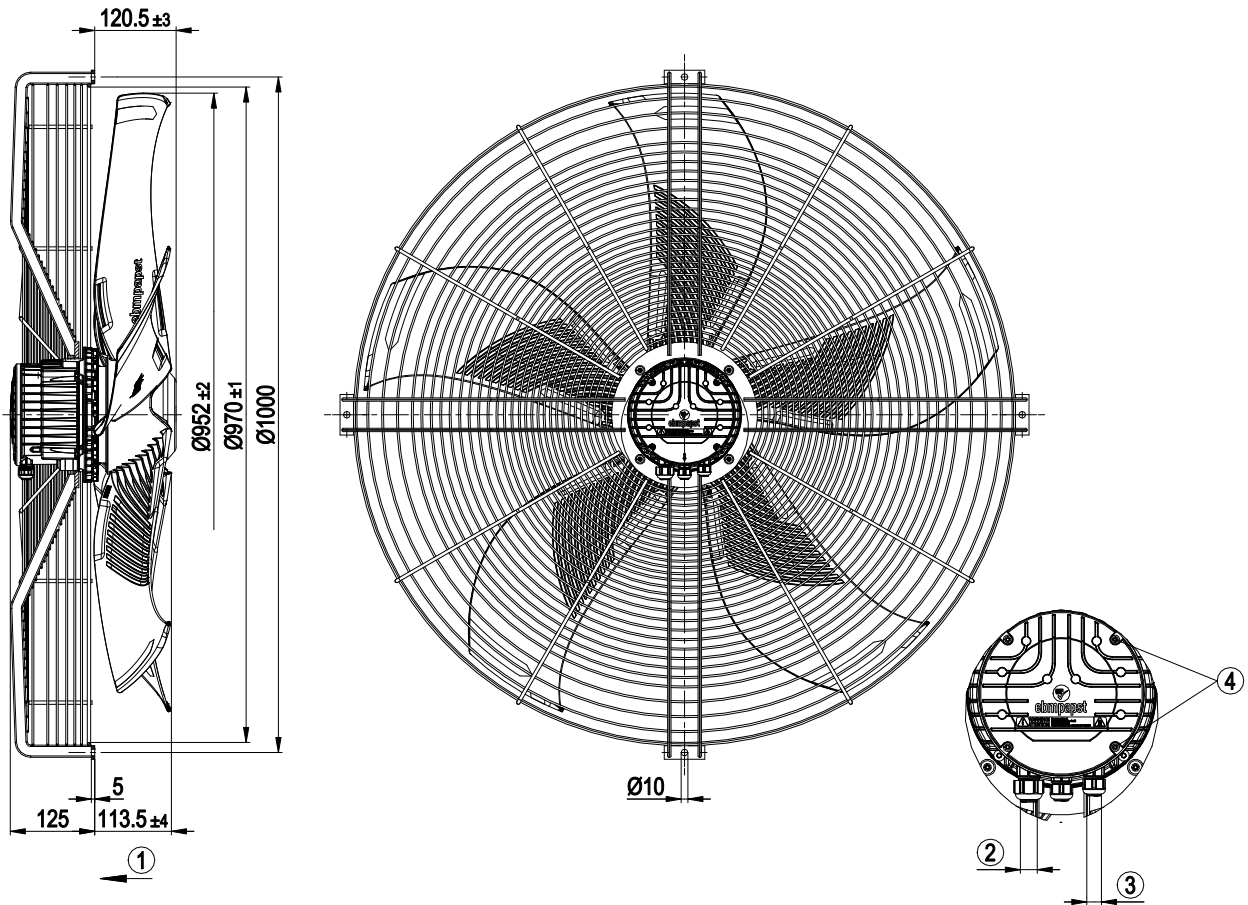

1	Airflow direction "V"
2	Cable diameter min. 8 mm, max. 12 mm, tightening torque 1.8±0.3 Nm (use must be made of seal provided) Cable diameter min. 4 mm, max. 10 mm, tightening torque 1.8±0.3 Nm
3	Cable diameter min. 6 mm, max. 10 mm, tightening torque 1.8±0.3 Nm (use must be made of seal provided) Cable diameter min. 4 mm, max. 7 mm, tightening torque 1.8±0.3 Nm
4	Tightening torque 3.5 ± 0.5 Nm



# EC axial fan

sickle-shaped blades (S series)

with guard grille for full nozzle

## Connection diagram

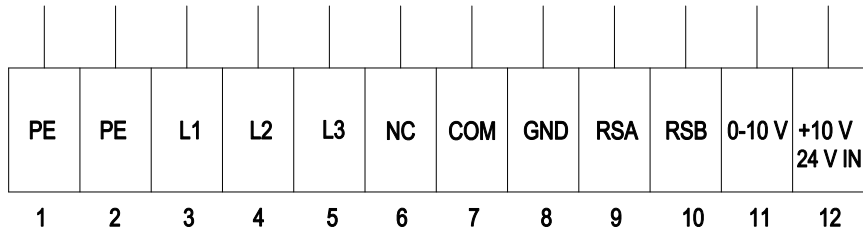

No.	Conn.	Designation	Function/assignment
1	PE	PE	Protective earth
2	PE	PE	Protective earth
3	L1	L1	Power supply
4	L2	L2	Power supply
5	L3	L3	Power supply
6	NC	NC	Status relay, floating status contact, break for failure, contact rating 250 VAC / 2 A (AC1) / min. 10 mA; reinforced insulation on supply side and basic insulation on control interface side
7	COM	COM	Status relay, floating status contact, break for failure, contact rating 250 VAC / 2 A (AC1) / min. 10 mA; reinforced insulation on supply side and basic insulation on control interface side
8	GND	GND	Reference ground for control interface, SELV
9	RSA	RSA	RS485 interface for MODBUS, RSA; SELV
10	RSB	RSB	RS485 interface for MODBUS, RSB; SELV
11	0-10 V	0-10 V	Analog input (set value) SELV, 0-10 V, Ri = 100 kΩ, adjustable curve
12	+10 V	+10 V	Fixed voltage output 10 VDC, SELV, +10 V ±3%, max. 10 mA, short-circuit-proof, power supply for external devices (e.g. pot); fixed voltage input 24 VDC for setting parameters via MODBUS without line voltage supply



# EC axial fan

sickle-shaped blades (S series)  
with guard grille for full nozzle

## Curves: Air performance 50 Hz

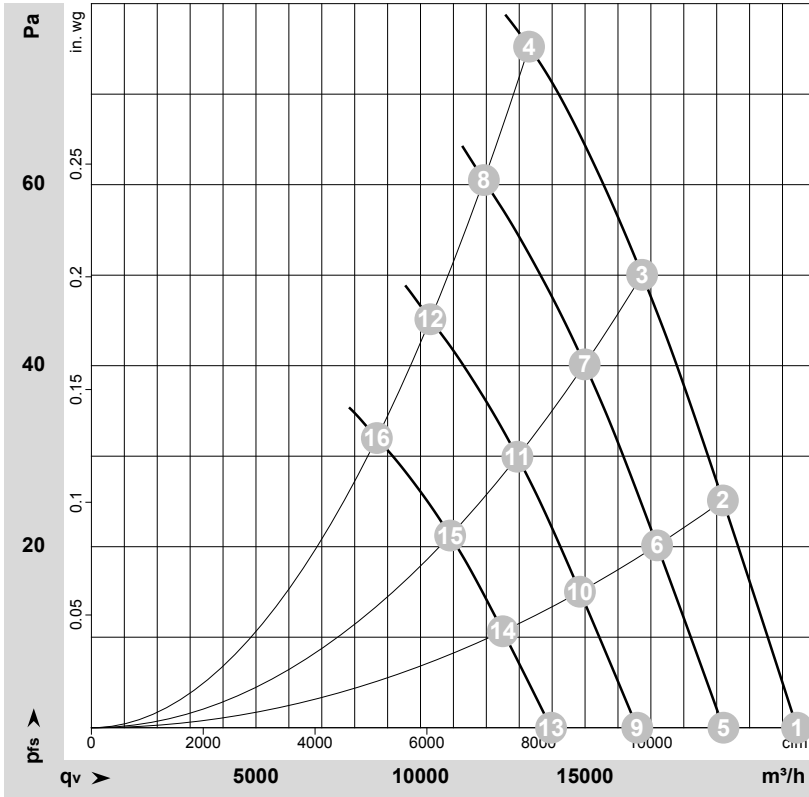

$\rho = 1.15 \text{ kg/m}^3 \pm 2 \%$

Measurement: LU-185907-1

Air performance measured according to ISO 5801 installation category A. For detailed information on the measurement setup, contact ebmpapst. Intake sound level: Sound power level according to ISO 13347 / sound pressure level measured at 1 m distance from fan axis. The values given are valid under the specified measuring conditions and may vary due to conditions of installation. For deviations from the standard configuration, the parameters have to be checked on the installed unit.

## Measured values

	Wired	U	f	n	P <sub>ed</sub>	I	LpA <sub>in</sub>	LwA <sub>in</sub>	LwA <sub>out</sub>	q <sub>v</sub>	P <sub>fs</sub>	q <sub>v</sub>	P <sub>fs</sub>
		V	Hz	min <sup>-1</sup>	W	A	dB(A)	dB(A)	dB(A)	m <sup>3</sup> /h	Pa	cfm	in. wg
1	3~	400	50	610	407	0.67	61	68	67	21440	0	12620	0.00
2	3~	400	50	610	485	0.78	59	65	65	19190	25	11295	0.10
3	3~	400	50	610	557	0.89	58	65	65	16735	50	9850	0.20
4	3~	400	50	610	630	1.00	62	69	69	13300	75	7825	0.30
5	3~	400	50	550	292	0.48	59	65	64	19205	0	11305	0.00
6	3~	400	50	550	349	0.56	56	63	63	17190	20	10115	0.08
7	3~	400	50	550	400	0.64	56	62	62	14990	40	8820	0.16
8	3~	400	50	550	457	0.72	59	66	66	11925	60	7020	0.24
9	3~	400	50	475	188	0.31	55	61	61	16585	0	9765	0.00
10	3~	400	50	475	225	0.36	52	59	59	14845	15	8735	0.06
11	3~	400	50	475	258	0.41	52	59	59	12945	30	7620	0.12
12	3~	400	50	475	294	0.46	55	62	62	10300	45	6060	0.18
13	3~	400	50	400	112	0.18	51	57	56	13970	0	8220	0.00
14	3~	400	50	400	134	0.22	48	55	54	12500	11	7360	0.04
15	3~	400	50	400	154	0.25	48	54	54	10900	21	6415	0.08
16	3~	400	50	400	176	0.28	51	58	58	8675	32	5105	0.13

Wired = Wiring · U = Voltage · f = Frequency · n = Speed (rpm) · P<sub>ed</sub> = Power consumption · I = Current draw · LpA<sub>in</sub> = Sound pressure level intake side · LwA<sub>in</sub> = Sound power level intake side  
LwA<sub>out</sub> = Sound power level outlet side · q<sub>v</sub> = Air flow · P<sub>fs</sub> = Pressure increase

