

S3G910-CV02-09

Güntner AG & Co. KG

VT03063U.1

EC axial fan

sickle-shaped blades (S series)

with guard grille for full nozzle

S3G910-CV02-09 ebmpapst Datasheet

sales@fansco.com

www.fansco.com

Limited partnership · Headquarters Muldingen

Amtsgericht (court of registration) Stuttgart · HRA 590344

General partner Elektrobau Muldingen GmbH · Headquarters Muldingen

Amtsgericht (court of registration) Stuttgart · HRB 590142

Nominal data

| | | |
|--------------------------|--------------------|------------|
| Type | S3G910-CV02-09 | |
| Motor | M3G150-NA | |
| Phase | | 3~ |
| Nominal voltage | VAC | 400 |
| Nominal voltage range | VAC | 380 .. 480 |
| Frequency | Hz | 50/60 |
| Method of obtaining data | | ml |
| Speed (rpm) | min ⁻¹ | 960 |
| Power consumption | W | 2370 |
| Current draw | A | 3.7 |
| Max. back pressure | Pa | 150 |
| Max. back pressure | inH ₂ O | 0.6 |
| Min. ambient temperature | °C | -25 |
| Max. ambient temperature | °C | 70 |

ml = Max. load · me = Max. efficiency · fa = Free air · cs = Customer specification · ce = Customer equipment
Subject to change

Data according to ErP Directive

| | | Actual | Req. 2015 | | | |
|-----------------------------------|---|--------|-----------|-------------------------------|-------------------|-------|
| 01 Overall efficiency η_{es} | % | 44.5 | 36.6 | 09 Power consumption P_{ed} | kW | 2.93 |
| 02 Measurement category | | A | | 09 Air flow q_v | m ³ /h | 22085 |
| 03 Efficiency category | | Static | | 09 Pressure increase p_{fs} | Pa | 202 |
| 04 Efficiency grade N | | 47.9 | 40 | 10 Speed (rpm) n | min ⁻¹ | 1005 |
| 05 Variable speed drive | | Yes | | 11 Specific ratio* | | 1.00 |

Data obtained at optimum efficiency level.

The ErP data is determined using a motor-impeller combination in a standardized measurement setup.

* Specific ratio = $1 + p_s / 100\,000\text{ Pa}$

LU-119173



S3G910-CV02-09

Güntner AG & Co. KG

VT03063U.1

EC axial fan

sickle-shaped blades (S series)

with guard grille for full nozzle

Technical description

| | |
|--|---|
| Weight | 42.6 kg |
| Fan size | 910 mm |
| Rotor surface | Painted black |
| Electronics housing material | Die-cast aluminum, painted black |
| Blade material | Die-cast aluminum |
| Guard grille material | Steel, coated with black plastic (RAL 9005) |
| Number of blades | 5 |
| Blade pitch | 0° |
| Airflow direction | "V" |
| Direction of rotation | Clockwise, viewed toward rotor |
| Degree of protection | IP55 |
| Insulation class | "F" |
| Moisture (F) / Environmental (H) protection class | F4-1 |
| Max. permitted ambient temp. for motor (transport/storage) | +80 °C |
| Min. permitted ambient temp. for motor (transport/storage) | -40 °C |
| Installation position | Shaft horizontal or rotor on bottom |
| Condensation drainage holes | On rotor side |
| Mode | S1 |
| Motor bearing | Ball bearing |
| Technical features | <ul style="list-style-type: none">- Output 10 VDC, max. 10 mA- Operation and alarm display- Bus terminating resistor 120 Ohm- External 24 V input (parameter setting)- Alarm relay- Integrated PID controller- Motor current limitation- PFC, passive- RS-485 MODBUS-RTU- Soft start- Control input 0-10 VDC / PWM- Control interface with SELV potential safely disconnected from the mains- Thermal overload protection for electronics/motor- Line undervoltage / phase failure detection |
| EMC immunity to interference | According to EN 61000-6-2 (industrial environment) |
| EMC interference emission | According to EN 61000-6-3 (household environment) |
| Touch current according to IEC 60990 (measuring circuit Fig. 4, TN system) | <= 3.5 mA |
| Electrical hookup | Via terminal box |
| Motor protection | Reverse polarity and locked-rotor protection |
| Protection class | I (with customer connection of protective earth) |
| Conformity with standards | EN 61800-5-1; CE |
| Approval | UL 1004-7 + 60730; EAC; C22.2 No.77 + CAN/CSA-E60730-1 |



S3G910-CV02-09

Güntner AG & Co. KG

VT03063U.1

EC axial fan

sickle-shaped blades (S series)

with guard grille for full nozzle

Product drawing

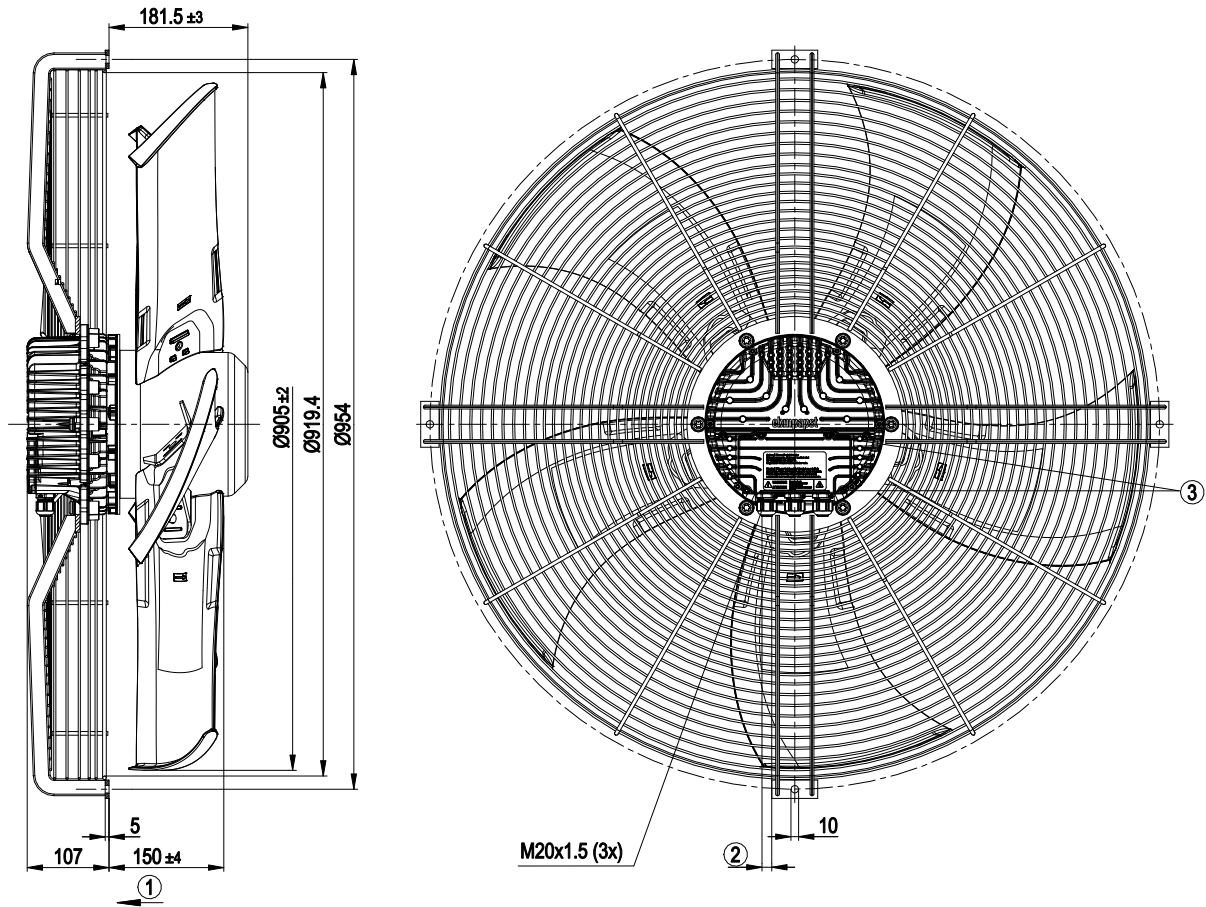

| | |
|---|--|
| 1 | Direction of air flow "V" |
| 2 | Cable diameter min. 4 mm, max. 10 mm; tightening torque 4 ± 0.6 Nm |
| 3 | Tightening torque 3.5 ± 0.5 Nm |



EC axial fan

sickle-shaped blades (S series)

with guard grille for full nozzle

Connection diagram

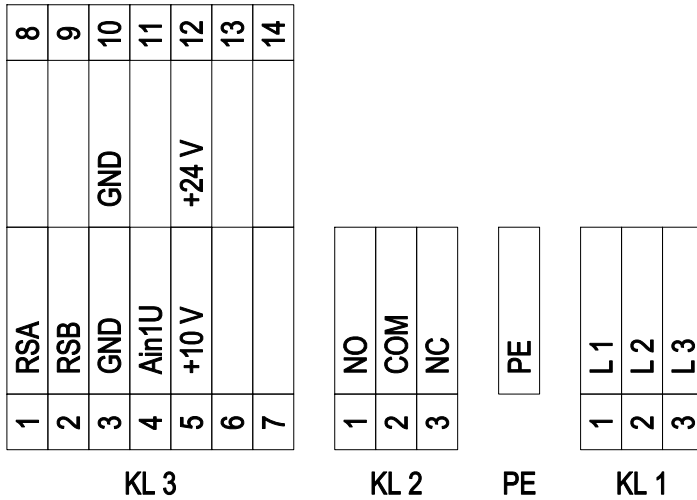

| No. | Conn. | Designation | Function/assignment |
|------|---------|-------------|--|
| KL 1 | 1, 2, 3 | L1, L2, L3 | Supply connection, power supply; for nominal voltage range see technical data |
| PE | | PE | Ground connection |
| KL2 | 1 | NO | Status relay, floating status contact, make for failure |
| KL2 | 2 | COM | Status relay, floating status contact, changeover contact, common connection, contact rating 250 VAC / max. 2 A (AC1) / min. 10 mA |
| KL 2 | 3 | NC | Status relay, floating status contact, break for failure |
| KL 3 | 1 | RSA | Bus connection RS485, RSA, MODBUS-RTU; SELV |
| KL 3 | 2 | RSB | Bus connection RS485, RSB, MODBUS-RTU; SELV |
| KL 3 | 3 | GND | Reference ground for control interface; SELV |
| KL 3 | 4 | Ain1 U | Analog input 1, set value: 0-10 V, Ri = 100 kΩ, adjustable curve, only usable as alternative to input Ain1 I; SELV |
| KL3 | 5 | +10 V | Fixed voltage output 10 VDC, +10 V ±3%, max. 10 mA, short-circuit-proof power supply for external devices (e.g. pot); SELV |
| KL3 | 6 | | not used |
| KL3 | 7 | | not used |
| KL3 | 8 | | not used |
| KL3 | 9 | | not used |
| KL 3 | 10 | GND | Reference ground for control interface; SELV |
| KL 3 | 11 | | not used |
| KL 3 | 12 | +24 V | Parameter-setting input 24 VDC, external feed +24 VDC for setting parameters |
| KL 3 | 13 | | not used |
| KL3 | 14 | | not used |



S3G910-CV02-09

Güntner AG & Co. KG

VT03063U.1

EC axial fan

sickle-shaped blades (S series)

with guard grille for full nozzle

Curves: Air performance 50 Hz

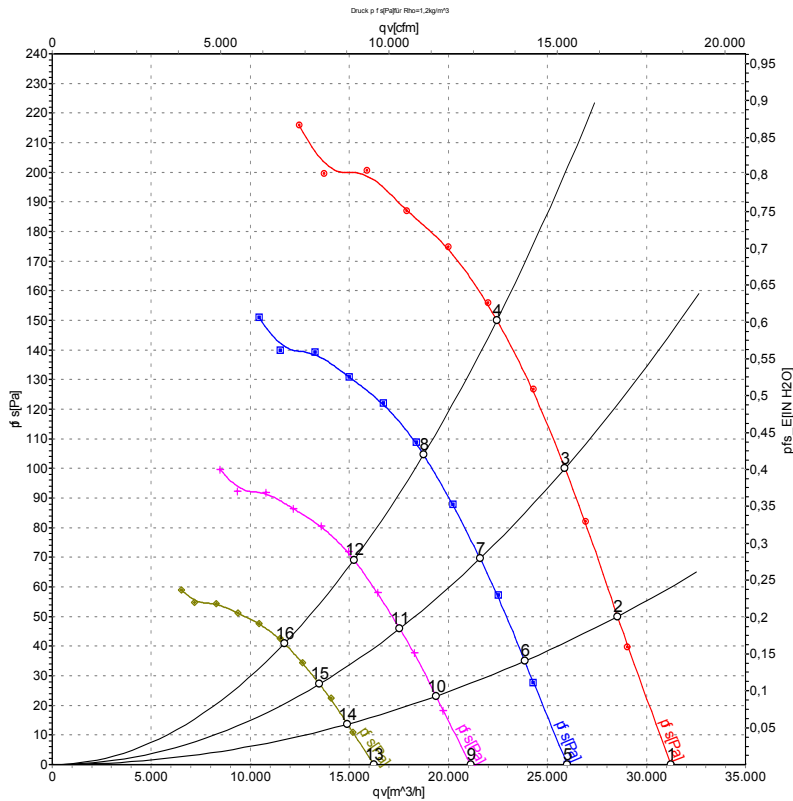

Measurement: LU-115717-1

Air performance measured according to ISO 5801 installation category A. For detailed information on the measurement setup, contact ebmpapst. Intake sound level: Sound power level according to ISO 13347 / sound pressure level measured at 1 m distance from fan axis. The values given are valid under the specified measuring conditions and may vary due to conditions of installation. For deviations from the standard configuration, the parameters have to be checked on the installed unit.

Measured values

| | U | f | n | P _{ed} | I | LpA _{in} | LwA _{in} | LwA _{out} | q _v | P _{fs} | q _v | P _{fs} |
|----|-----|----|-------------------|-----------------|------|-------------------|-------------------|--------------------|-------------------|-----------------|----------------|-----------------|
| | V | Hz | min ⁻¹ | W | A | dB(A) | dB(A) | dB(A) | m ³ /h | Pa | cfm | inH2O |
| 1 | 400 | 50 | 960 | 1793 | 2.74 | 74 | 82 | 83 | 31230 | 0 | 18380 | 0.00 |
| 2 | 400 | 50 | 960 | 1978 | 3.00 | 74 | 81 | 82 | 28540 | 50 | 16800 | 0.20 |
| 3 | 400 | 50 | 960 | 2176 | 3.31 | 74 | 81 | 82 | 25880 | 100 | 15230 | 0.40 |
| 4 | 400 | 50 | 960 | 2370 | 3.70 | 75 | 82 | 83 | 22440 | 150 | 13210 | 0.60 |
| 5 | 400 | 50 | 800 | 1034 | 1.58 | 70 | 78 | 79 | 26000 | 0 | 15305 | 0.00 |
| 6 | 400 | 50 | 800 | 1157 | 1.76 | 70 | 77 | 78 | 23860 | 35 | 14045 | 0.14 |
| 7 | 400 | 50 | 800 | 1264 | 1.92 | 70 | 77 | 78 | 21590 | 70 | 12705 | 0.28 |
| 8 | 400 | 50 | 800 | 1368 | 2.08 | 71 | 78 | 79 | 18740 | 105 | 11030 | 0.42 |
| 9 | 400 | 50 | 650 | 555 | 0.85 | 66 | 73 | 74 | 21130 | 0 | 12435 | 0.00 |
| 10 | 400 | 50 | 650 | 620 | 0.94 | 66 | 73 | 74 | 19380 | 23 | 11405 | 0.09 |
| 11 | 400 | 50 | 650 | 678 | 1.03 | 66 | 73 | 74 | 17540 | 46 | 10325 | 0.18 |
| 12 | 400 | 50 | 650 | 734 | 1.12 | 67 | 74 | 75 | 15230 | 69 | 8965 | 0.28 |
| 13 | 400 | 50 | 500 | 253 | 0.39 | 60 | 68 | 69 | 16250 | 0 | 9565 | 0.00 |
| 14 | 400 | 50 | 500 | 282 | 0.43 | 60 | 67 | 68 | 14910 | 14 | 8775 | 0.06 |
| 15 | 400 | 50 | 500 | 309 | 0.47 | 60 | 67 | 68 | 13500 | 27 | 7945 | 0.11 |
| 16 | 400 | 50 | 500 | 334 | 0.51 | 61 | 68 | 69 | 11710 | 41 | 6890 | 0.16 |

U = Power supply · f = Frequency · n = Speed (rpm) · P_{ed} = Power consumption · I = Current draw · LpA_{in} = Sound pressure level intake side · LwA_{in} = Sound power level intake side
 LwA_{out} = Sound power level outlet side · q_v = Air flow · P_{fs} = Pressure increase

