

S3G910-CO83-09 ebmpapst Datasheet  
 sales@fansco.com  
 www.fansco.com

Limited partnership · Headquarters Mulfingen  
 Amtsgericht (court of registration) Stuttgart · HRA 590344  
 General partner Elektrobau Mulfingen GmbH · Headquarters Mulfingen  
 Amtsgericht (court of registration) Stuttgart · HRB 590142

## Nominal data

Type	S3G910-CO83-09	
Motor	M3G112-IA	
Phase		3~
Nominal voltage	VAC	400
Nominal voltage range	VAC	380 .. 480
Frequency	Hz	50/60
Method of obtaining data		ml
Speed (rpm)	min <sup>-1</sup>	650
Power consumption	W	580
Current draw	A	1.1
Max. back pressure	Pa	31
Max. back pressure	inH <sub>2</sub> O	0.12
Min. ambient temperature	°C	-25
Max. ambient temperature	°C	70

ml = Max. load · me = Max. efficiency · fa = Free air · cs = Customer specification · ce = Customer equipment  
 Subject to change

## Data according to ErP Directive

		Actual	Req. 2015			
01 Overall efficiency $\eta_{es}$	%	45.5	32.2	09 Power consumption $P_{ed}$	kW	0.59
02 Measurement category		A		09 Air flow $q_v$	m <sup>3</sup> /h	11680
03 Efficiency category		Static		09 Pressure increase $p_{fs}$	Pa	76
04 Efficiency grade N		53.3	40	10 Speed (rpm) n	min <sup>-1</sup>	615
05 Variable speed drive		Yes		11 Specific ratio*		1.00

Data obtained at optimum efficiency level.  
 The ErP data is determined using a motor-impeller combination in a standardized measurement setup.

\* Specific ratio =  $1 + p_s / 100\,000\text{ Pa}$

LU-120677



## Technical description

Weight	20 kg
Fan size	910 mm
Rotor surface	Painted black
Electronics housing material	Die-cast aluminum, painted black
Blade material	Press-fitted sheet steel blank, sprayed with PP plastic
Support plate material	Sheet steel, sendzimir galvanized; aluminum spacer profiles
Guard grille material	Steel, coated with black plastic (RAL 9005)
Number of blades	5
Airflow direction	"V"
Direction of rotation	Clockwise, viewed toward rotor
Degree of protection	IP54
Insulation class	"F"
Moisture (F) / Environmental (H) protection class	F4-1
Max. permitted ambient temp. for motor (transport/storage)	+ 80 °C
Min. permitted ambient temp. for motor (transport/storage)	- 40 °C
Installation position	Shaft horizontal or rotor on bottom; rotor on top on request
Condensation drainage holes	On rotor side
Mode	S1
Motor bearing	Ball bearing
Technical features	<ul style="list-style-type: none"> <li>- External 24 V input (parameter setting)</li> <li>- Integrated PID controller</li> <li>- Motor current limitation</li> <li>- PFC, passive</li> <li>- RS-485 MODBUS-RTU</li> <li>- Soft start</li> <li>- Control input 0-10 VDC / PWM</li> <li>- Control interface with SELV potential safely disconnected from the mains</li> <li>- Thermal overload protection for electronics/motor</li> <li>- Line undervoltage / phase failure detection</li> </ul>
EMC immunity to interference	According to EN 61000-6-2 (industrial environment)
EMC circuit feedback	According to EN 61000-3-2/3
Touch current according to IEC 60990 (measuring circuit Fig. 4, TN system)	≤ 3.5 mA
Electrical hookup	Via terminal box
Motor protection	Thermal overload protector (TOP) internally connected
Protection class	I (with customer connection of protective earth)
Conformity with standards	EN 61800-5-1; CE
Approval	UL 1004-7 + 60730; EAC



Product drawing

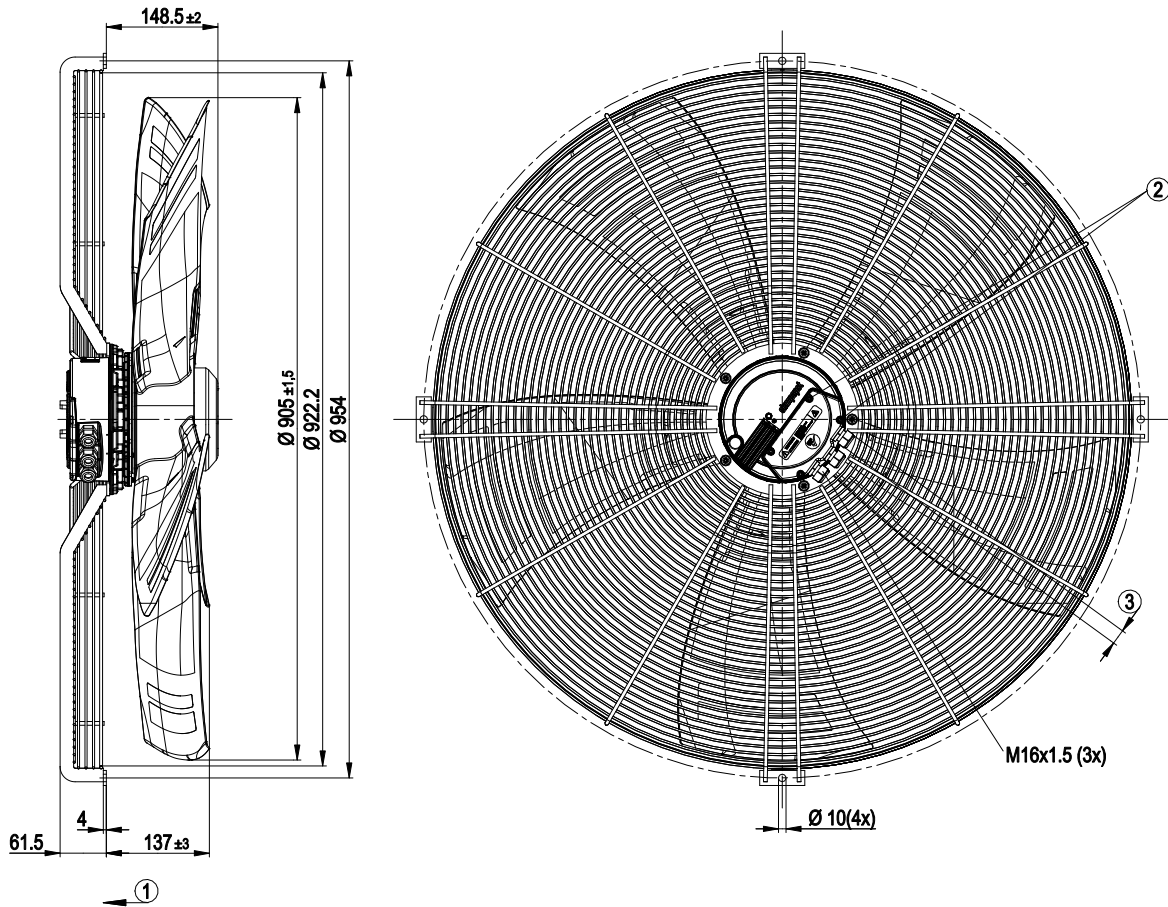

1	Direction of air flow "V"
2	Tightening torque 3.5 ± 0.5 Nm
3	Cable diameter min. 4 mm; max. 10 mm; tightening torque 2.5±0.4 Nm



## Connection diagram

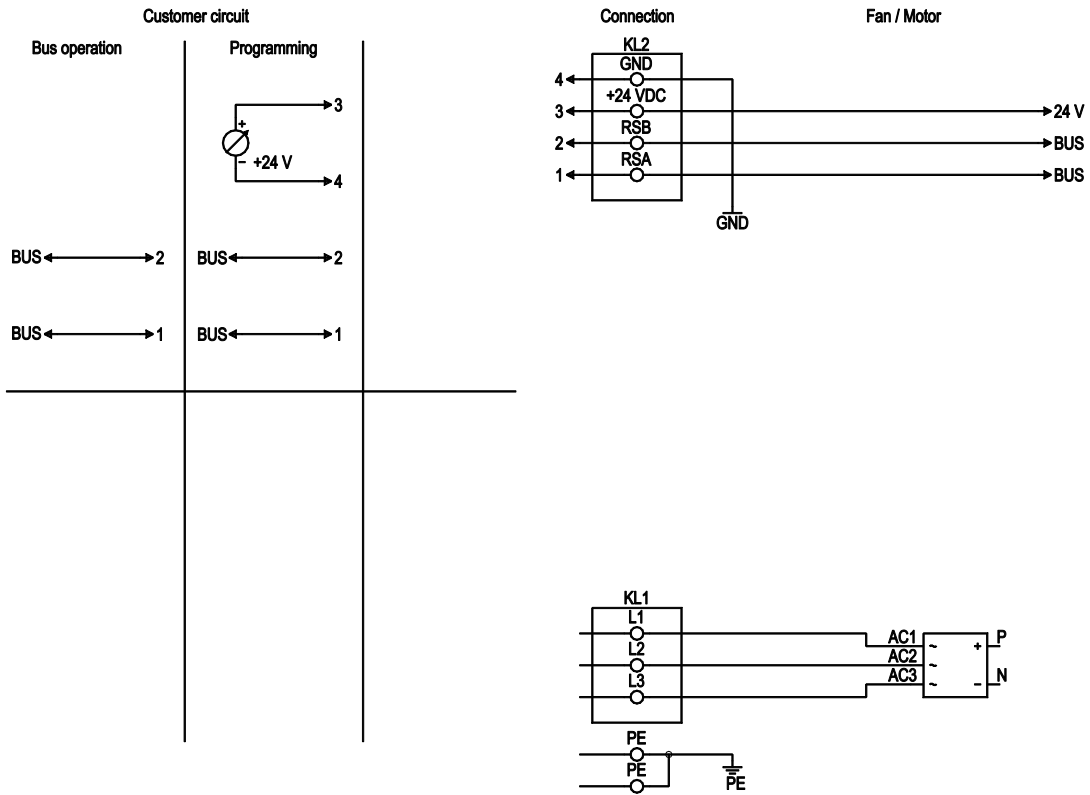

No.	Conn.	Designation	Function/assignment
PE	-	PE	Protective earth terminal
KL1	1, 2, 3	L1, L2, L3	Power supply 50/60 Hz
KL2	1	RSA	RS485 interface for MODBUS, RSA
KL2	2	RSB	RS485 interface for MODBUS, RSB
KL2	3	+24 VDC	Feed-in max. 24 VDC for setting electronics parameters
KL2	4	GND	Reference ground



## Curves: Air performance 50 Hz

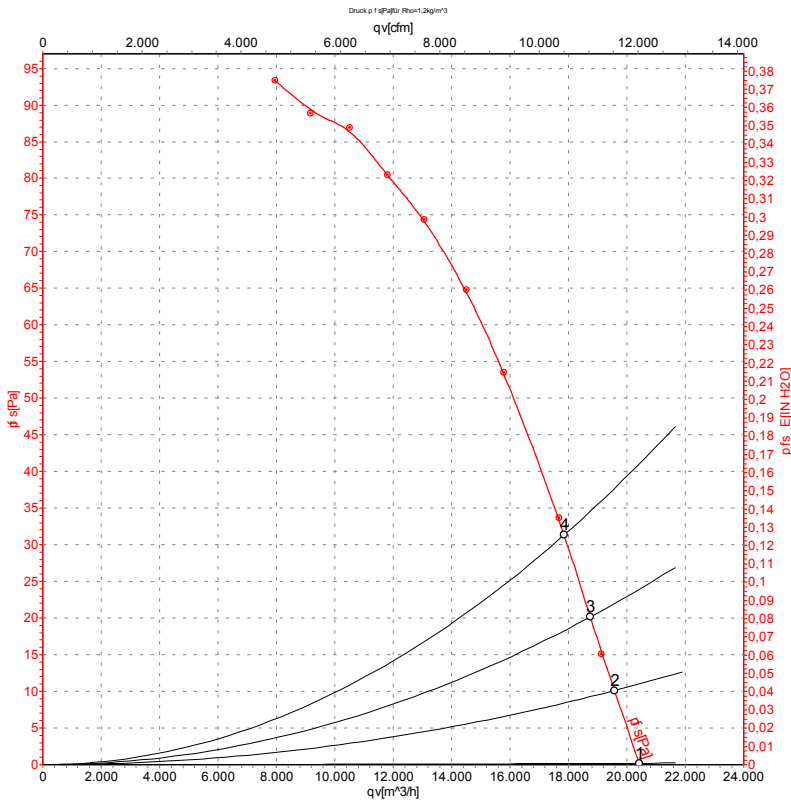

Measurement: LU-115751-1

Air performance measured according to ISO 5801 installation category A. For detailed information on the measurement setup, contact ebm-papst. Intake sound level: Sound power level according to ISO 13347 / sound pressure level measured at 1 m distance from fan axis. The values given are valid under the specified measuring conditions and may vary due to conditions of installation. For deviations from the standard configuration, the parameters have to be checked on the installed unit.

## Measured values

	U	f	n	P <sub>ed</sub>	I	q <sub>v</sub>	p <sub>fs</sub>	q <sub>v</sub>	p <sub>fs</sub>
	V	Hz	min <sup>-1</sup>	W	A	m <sup>3</sup> /h	Pa	cfm	inH <sub>2</sub> O
1	400	50	650	499	0.90	20420	0	12020	0.00
2	400	50	650	522	0.92	19580	10	11525	0.04
3	400	50	650	546	0.95	18750	20	11035	0.08
4	400	50	650	580	1.10	17850	31	10505	0.12

U = Power supply · f = Frequency · n = Speed (rpm) · P<sub>ed</sub> = Power consumption · I = Current draw · q<sub>v</sub> = Air flow · p<sub>fs</sub> = Pressure increase

