

S3G800-CN36-25 ebmpapst Datasheet

sales@fansco.com

www.fansco.com

Limited partnership · Headquarters Muldingen

Amtsgericht (court of registration) Stuttgart · HRA 590344

General partner Elektrobau Muldingen GmbH · Headquarters Muldingen

Amtsgericht (court of registration) Stuttgart · HRB 590142



Nominal data

| | | |
|--------------------------|--------------------|------------|
| Type | S3G800-CN36-25 | |
| Motor | M3G112-GA | |
| Phase | | 1~ |
| Nominal voltage | VAC | 230 |
| Nominal voltage range | VAC | 200 .. 277 |
| Frequency | Hz | 50/60 |
| Method of obtaining data | | ml/ce |
| Speed (rpm) | min ⁻¹ | 600 |
| Power consumption | W | 340 |
| Current draw | A | 1.5 |
| Max. back pressure | Pa | 37 |
| Max. back pressure | inH ₂ O | 0.15 |
| Min. ambient temperature | °C | -25 |
| Max. ambient temperature | °C | 65 |

ml = Max. load · me = Max. efficiency · fa = Free air · cs = Customer specification · ce = Customer equipment
Subject to change

Data according to ErP Directive

| | | Actual | Req. 2015 | | |
|-----------------------------------|---|--------|-----------|-------------------------------|-------------------|
| 01 Overall efficiency η_{es} | % | 42.6 | 31.1 | 09 Power consumption P_{ed} | kW |
| 02 Measurement category | | A | | 09 Air flow q_v | m ³ /h |
| 03 Efficiency category | | Static | | 09 Pressure increase p_{fs} | Pa |
| 04 Efficiency grade N | | 51.5 | 40 | 10 Speed (rpm) n | min ⁻¹ |
| 05 Variable speed drive | | Yes | | 11 Specific ratio* | |
| | | | | | 1.00 |

Data obtained at optimum efficiency level.

The ErP data is determined using a motor-impeller combination in a standardized measurement setup.

* Specific ratio = $1 + p_s / 100\,000\text{ Pa}$

LU-126143



Technical description

| | |
|--|--|
| Weight | 16.4 kg |
| Fan size | 800 mm |
| Rotor surface | Painted black |
| Electronics housing material | Die-cast aluminum, painted black |
| Blade material | Press-fitted sheet steel blank, sprayed with PP plastic |
| Guard grille material | Steel, coated with black plastic (RAL 9005) |
| Number of blades | 5 |
| Airflow direction | "V" |
| Direction of rotation | Clockwise, viewed toward rotor |
| Degree of protection | IP54 |
| Insulation class | "B" |
| Moisture (F) / Environmental (H) protection class | F4-1 |
| Max. permitted ambient temp. for motor (transport/storage) | +80 °C |
| Min. permitted ambient temp. for motor (transport/storage) | -40 °C |
| Installation position | Shaft horizontal or rotor on bottom; rotor on top on request |
| Condensation drainage holes | On rotor side |
| Mode | S1 |
| Motor bearing | Ball bearing |
| Technical features | <ul style="list-style-type: none"> - Output 10 VDC, max. 10 mA - Output 20 VDC, max. 50 mA - Output for slave 0-10 V - Input for sensor 0-10 V or 4-20 mA - Alarm relay - Integrated PID controller - Motor current limitation - PFC, active - RS-485 ebmBUS - Soft start - Control input 0-10 VDC / PWM - Control interface with SELV potential safely disconnected from supply - Thermal overload protection for electronics/motor - Line undervoltage / phase failure detection |
| EMC immunity to interference | According to EN 61000-6-2 (industrial environment) |
| EMC circuit feedback | According to EN 61000-3-2/3 |
| EMC interference emission | According to EN 61000-6-4 (industrial environment) |
| Touch current according to IEC 60990 (measuring circuit Fig. 4, TN system) | <= 3.5 mA |
| Motor protection | Thermal overload protector (TOP) internally connected |
| With cable | Variable |
| Protection class | I (with customer connection of protective earth) |
| Conformity with standards | CE |

EC axial fan - HyBlade

sickle-shaped blades (S series)

with guard grille for full nozzle

Product drawing

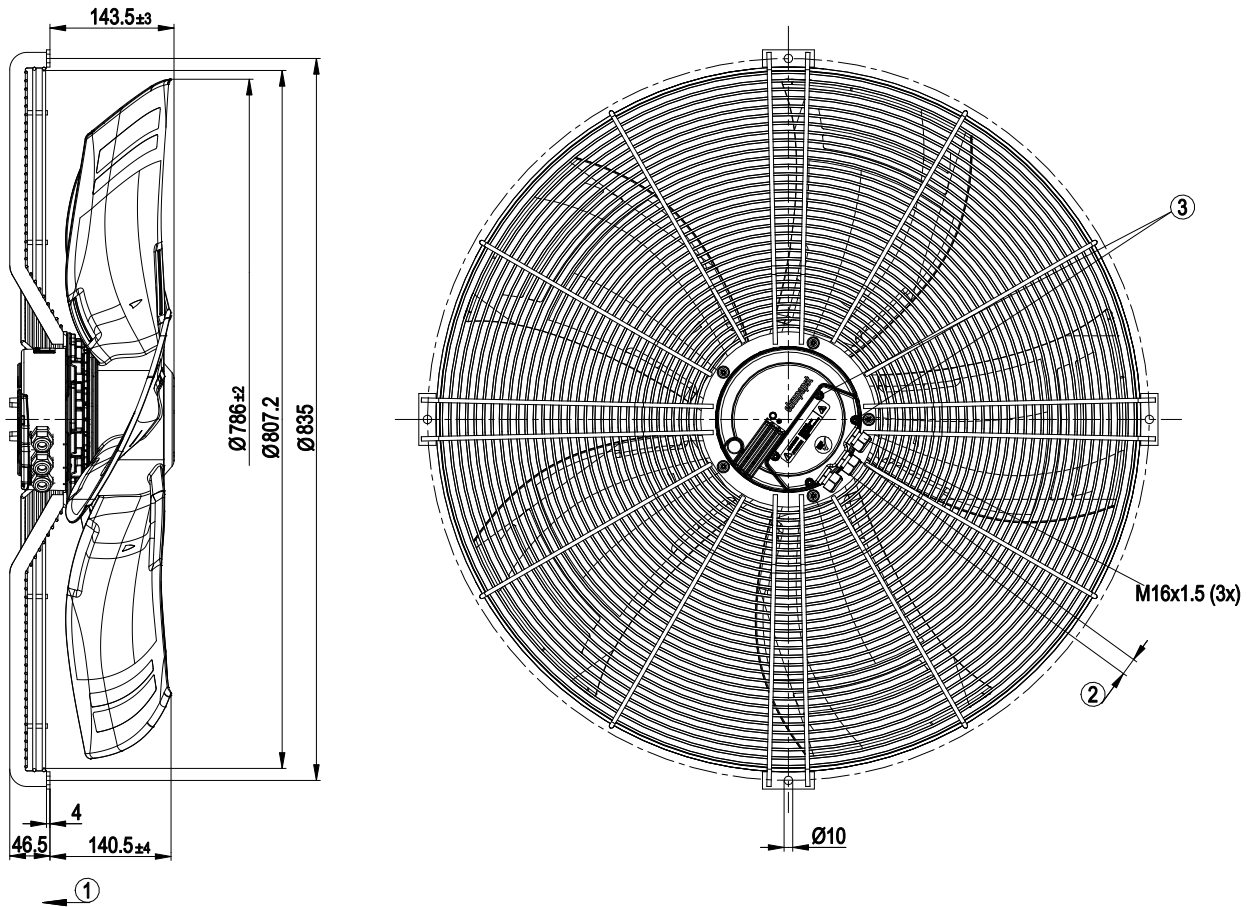

| | |
|---|--|
| 1 | Direction of air flow "V" |
| 2 | Cable diameter min. 4 mm; max. 10 mm; tightening torque 4±0.6 Nm |
| 3 | Tightening torque 3.5 ± 0.5 Nm |



EC axial fan - HyBlade

sickle-shaped blades (S series)

with guard grille for full nozzle

Connection diagram

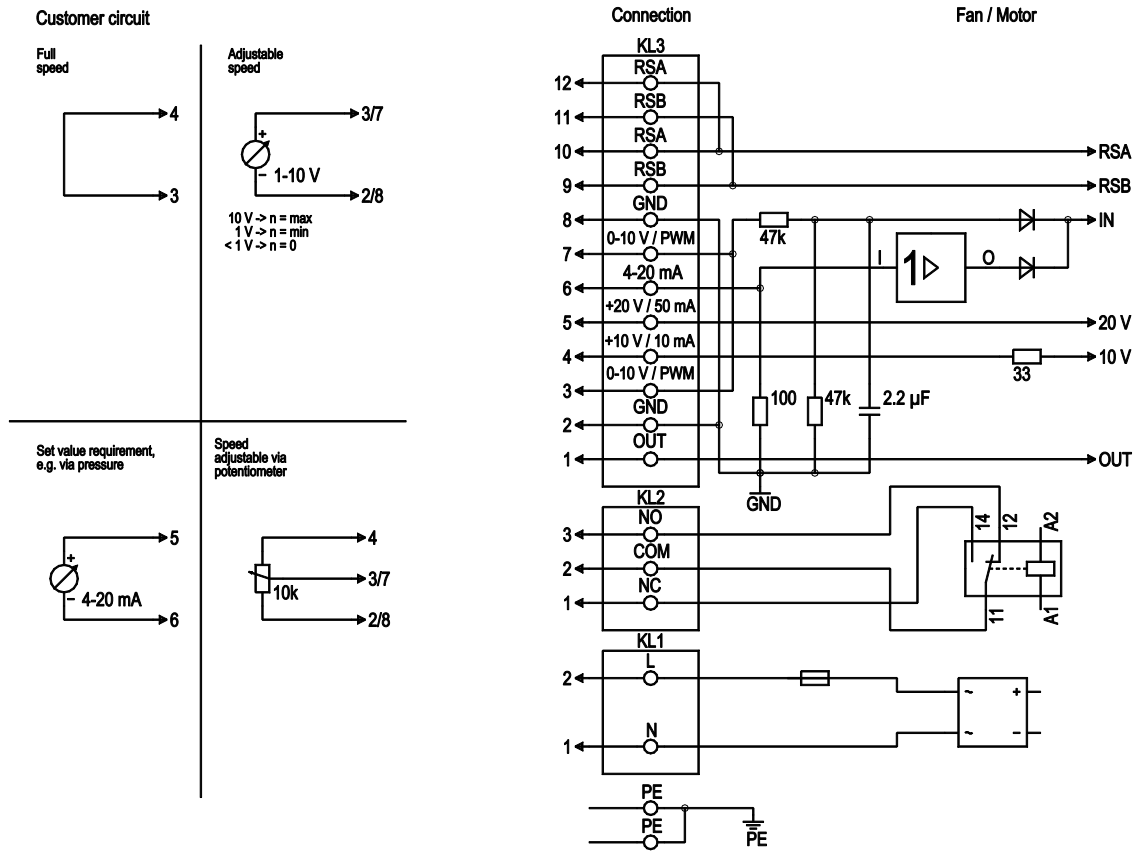

| No. | Conn. | Designation | Function/assignment |
|-----|--------|-------------|---|
| PE | | PE | Protective earth terminal |
| KL1 | 1, 2 | N, L | Power supply 50/60 Hz |
| KL2 | 1 | NC | Floating status contact, break for failure |
| KL2 | 2 | COM | Floating status contact, changeover contact, common connection (2 A, max. 250 VAC, min. 10 mA, AC1) |
| KL2 | 3 | NO | Floating status contact, make for failure |
| KL3 | 1 | OUT | Analog output, 0-10 VDC, max. 3 mA, SELV, output of current motor modulation level: 1 V corresponds to 10% modulation level. 10 V corresponds to 100% modulation level. |
| KL3 | 2, 8 | GND | Reference ground for control interface, SELV |
| KL3 | 3, 7 | 0-10 V | Use control / current sensor value input 0-10 VDC, impedance 100 kΩ only as alternative to 4-20 mA input, SELV |
| KL3 | 4 | +10 V | Voltage output 10 VDC (±3 %), max. 10 mA, power supply for external devices (e.g. potentiometer), SELV |
| KL3 | 5 | +20 V | Voltage output 20 VDC (+25% / -10%), max. 50 mA, power supply for external devices (e.g. sensors); SELV |
| KL3 | 6 | 4-20 mA | Use control / current sensor value input 4-20 mA, impedance 100 Ω only as alternative to 0-10 V input, SELV |
| KL3 | 9, 11 | RSB | RS485 interface for ebmBUS, RSB, SELV |
| KL3 | 10, 12 | RSA | RS485 interface for ebmBUS, RSA, SELV |



Curves: Air performance 50 Hz

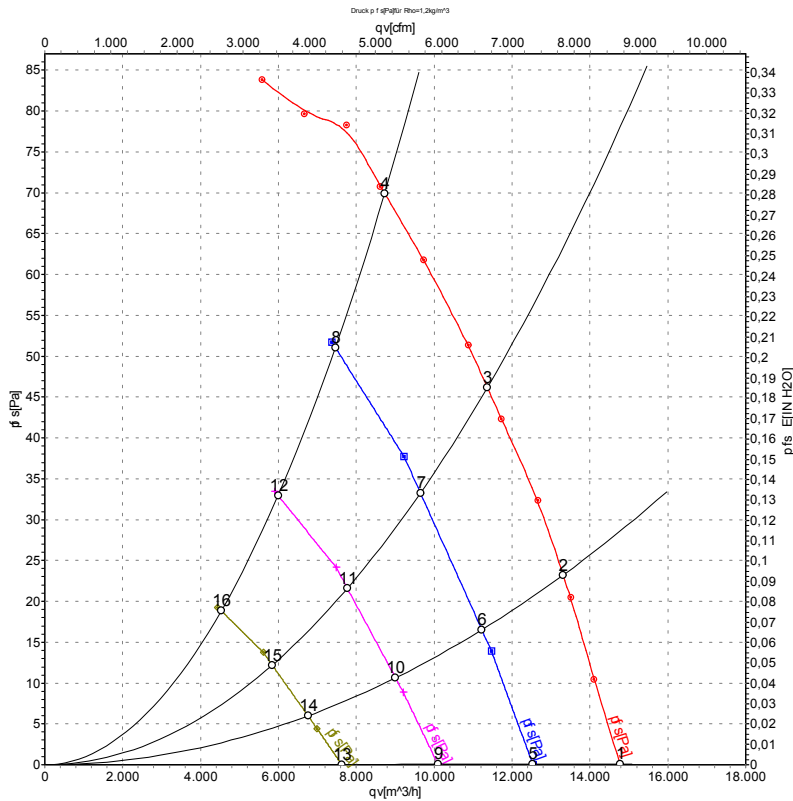

Measurement: LU-119388-1
 Measurement: LU-120591-1
 Measurement: LU-120592-1
 Measurement: LU-120593-1

Air performance measured according to ISO 5801 installation category A. For detailed information on the measurement setup, contact ebm-papst. Intake sound level: Sound power level according to ISO 13347 / sound pressure level measured at 1 m distance from fan axis. The values given are valid under the specified measuring conditions and may vary due to conditions of installation. For deviations from the standard configuration, the parameters have to be checked on the installed unit.

Measured values

| | U | f | n | P _{ed} | I | LpA _{in} | LwA _{in} | LwA _{out} | qv | P _{fs} | qv | P _{fs} |
|----|-----|----|-------------------|-----------------|------|-------------------|-------------------|--------------------|-------------------|-----------------|------|-----------------|
| | V | Hz | min ⁻¹ | W | A | dB(A) | dB(A) | dB(A) | m ³ /h | Pa | CFM | inH2O |
| 1 | 230 | 50 | 600 | 288 | 1.27 | 57 | 64 | 63 | 14770 | 0 | 8695 | 0.00 |
| 2 | 230 | 50 | 600 | 342 | 1.50 | 55 | 61 | 61 | 13310 | 23 | 7835 | 0.09 |
| 3 | 230 | 50 | 600 | 382 | 1.68 | 53 | 59 | 59 | 11370 | 46 | 6690 | 0.18 |
| 4 | 230 | 50 | 600 | 440 | 1.90 | 56 | 64 | 64 | 8730 | 70 | 5140 | 0.28 |
| 5 | 230 | 50 | 500 | 171 | 0.77 | 53 | 60 | 59 | 12530 | 0 | 7375 | 0.00 |
| 6 | 230 | 50 | 500 | 200 | 0.90 | 52 | 58 | 57 | 11230 | 16 | 6610 | 0.06 |
| 7 | 230 | 50 | 500 | 228 | 1.01 | 49 | 56 | 55 | 9645 | 33 | 5680 | 0.13 |
| 8 | 230 | 50 | 500 | 257 | 1.14 | 52 | 60 | 59 | 7460 | 51 | 4390 | 0.20 |
| 9 | 230 | 50 | 400 | 95 | 0.47 | 49 | 55 | 54 | 10100 | 0 | 5945 | 0.00 |
| 10 | 230 | 50 | 400 | 109 | 0.53 | 47 | 53 | 53 | 9005 | 11 | 5300 | 0.04 |
| 11 | 230 | 50 | 400 | 123 | 0.58 | 44 | 51 | 51 | 7770 | 22 | 4575 | 0.09 |
| 12 | 230 | 50 | 400 | 137 | 0.64 | 46 | 53 | 54 | 5990 | 33 | 3525 | 0.13 |
| 13 | 230 | 50 | 300 | 48 | 0.30 | 41 | 48 | 49 | 7625 | 0 | 4485 | 0.00 |
| 14 | 230 | 50 | 300 | 53 | 0.32 | 39 | 47 | 48 | 6760 | 6 | 3980 | 0.02 |
| 15 | 230 | 50 | 300 | 60 | 0.34 | 39 | 45 | 47 | 5840 | 12 | 3440 | 0.05 |
| 16 | 230 | 50 | 300 | 67 | 0.36 | 38 | 46 | 47 | 4530 | 19 | 2665 | 0.08 |

U = Power supply · f = Frequency · n = Speed (rpm) · P_{ed} = Power consumption · I = Current draw · LpA_{in} = Sound pressure level intake side · LwA_{in} = Sound power level intake side
 LwA_{out} = Sound power level outlet side · qv = Air flow · P_{fs} = Pressure increase

