

EC axial fan - HyBlade

sickled blades (S series)

with guard grille for full nozzle

S3G800-CA77-41 ebmpapst Datasheet

sales@fansco.com

www.fansco.com

Nominal data

| | | |
|--------------------------|-------------------|------------|
| Type | S3G800-CA77-41 | |
| Motor | M3G112-EA | |
| Phase | | 1~ |
| Nominal voltage | VAC | 230 |
| Nominal voltage range | VAC | 200 .. 277 |
| Frequency | Hz | 50/60 |
| Type of data definition | | ml |
| Speed (rpm) | min ⁻¹ | 490 |
| Power input | W | 240 |
| Current draw | A | 1.1 |
| Max. back pressure | Pa | 50 |
| Min. ambient temperature | °C | -25 |
| Max. ambient temperature | °C | 60 |

ml = Max. load · me = Max. efficiency · fa = Running at free air · cs = Customer specs · cu = Customer unit
Subject to alterations

Data in accordance with ecodesign regulation EU 327/2011 (EN 17166)

| | | Actual | Request 2015 | | |
|-----------------------------------|---|--------|--------------|-------------------------------|-------------------|
| 01 Overall efficiency η_{es} | % | 41.9 | 29.5 | 09 Power input P_{ed} | kW |
| 02 Measurement category | | A | | 09 Air flow q_v | m ³ /h |
| 03 Efficiency category | | Static | | 09 Pressure increase p_{fs} | Pa |
| 04 Efficiency grade N | | 52.4 | 40 | 10 Speed (rpm) n | min ⁻¹ |
| 05 Variable speed drive | | Yes | | 11 Specific ratio* | 1.00 |

Data definition with optimum efficiency.
The ErP data is determined using a motor-impeller combination in a standardised measurement configuration.

* Specific ratio = $1 + p_{fs} / 100\,000\text{ Pa}$

LU-157602



S3G800-CA77-41

EC axial fan - HyBlade

sickled blades (S series)

with guard grille for full nozzle

Technical features

| | |
|--------------------------------------------------------------------|---------------------------------------------------------------------------------------------------------------------------------------------------------------------------------------------------------------------------------------------------------------------------------------------------------------------------------------------------------------------------------------------------------------------------------------------------------------------------------------------------------------------------------------------------------------|
| Mass | 15.3 kg |
| Size | 800 mm |
| Motor size | 112 |
| Surface of rotor | Coated in black |
| Material of terminal box | PP plastic |
| Material of electronics housing | Die-cast aluminium, coated in black |
| Material of blades | Press-fitted sheet steel blank, sprayed with PP plastic |
| Material of guard grille | Steel, coated in black plastic (RAL9005) |
| Number of blades | 5 |
| Direction of air flow | V |
| Direction of rotation | Clockwise, seen on rotor |
| Type of protection | IP55 |
| Insulation class | "F" |
| Humidity (F) / environmental protection class (H) | H2 |
| Max. permissible ambient motor temp. (transp./ storage) | +80 °C |
| Min. permissible ambient motor temp. (transp./storage) | -40 °C |
| Mounting position | Shaft horizontal or rotor on bottom; rotor on top on request |
| Condensation drainage holes | Rotor-side |
| Operation mode | S1 |
| Motor bearing | Ball bearing; (sealed) |
| Technical features | <ul style="list-style-type: none"> - Output 10 VDC, max. 10 mA - Operation and alarm display - Alarm relay - Integrated PID controller - Output limit - Motor current limit - PFC, active - RS485 MODBUS RTU - Soft start - Control input 0-10 VDC / PWM - Control interface with SELV potential safely disconnected from the mains - Over-temperature protected electronics / motor - Line undervoltage / phase failure detection |
| EMC interference immunity | Acc. to EN 61000-6-2 (industrial environment) |
| EMC harmonics | Acc. to EN 61000-3-2/3 |
| EMC interference emission | Acc. to EN 61000-6-3 (household environment) |
| Touch current acc. IEC 60990 (measuring network Fig. 4, TN system) | <= 3.5 mA |
| Electrical connection | Terminal box |
| Motor protection | Thermal overload protector (TOP) wired internally |
| Protection class | I (if protective earth is connected by customer) |
| Product conforming to standard | EN 61800-5-1; CE |
| Approval | CSA C22.2 no. 77 + CAN/CSA-E60730-1; EAC; UL 1004-7 + 60730-1 |
| Remark | Standard conformity as per EN 60335-1 in preparation |



ebmpapst

EC axial fan - HyBlade

sickled blades (S series)

with guard grille for full nozzle

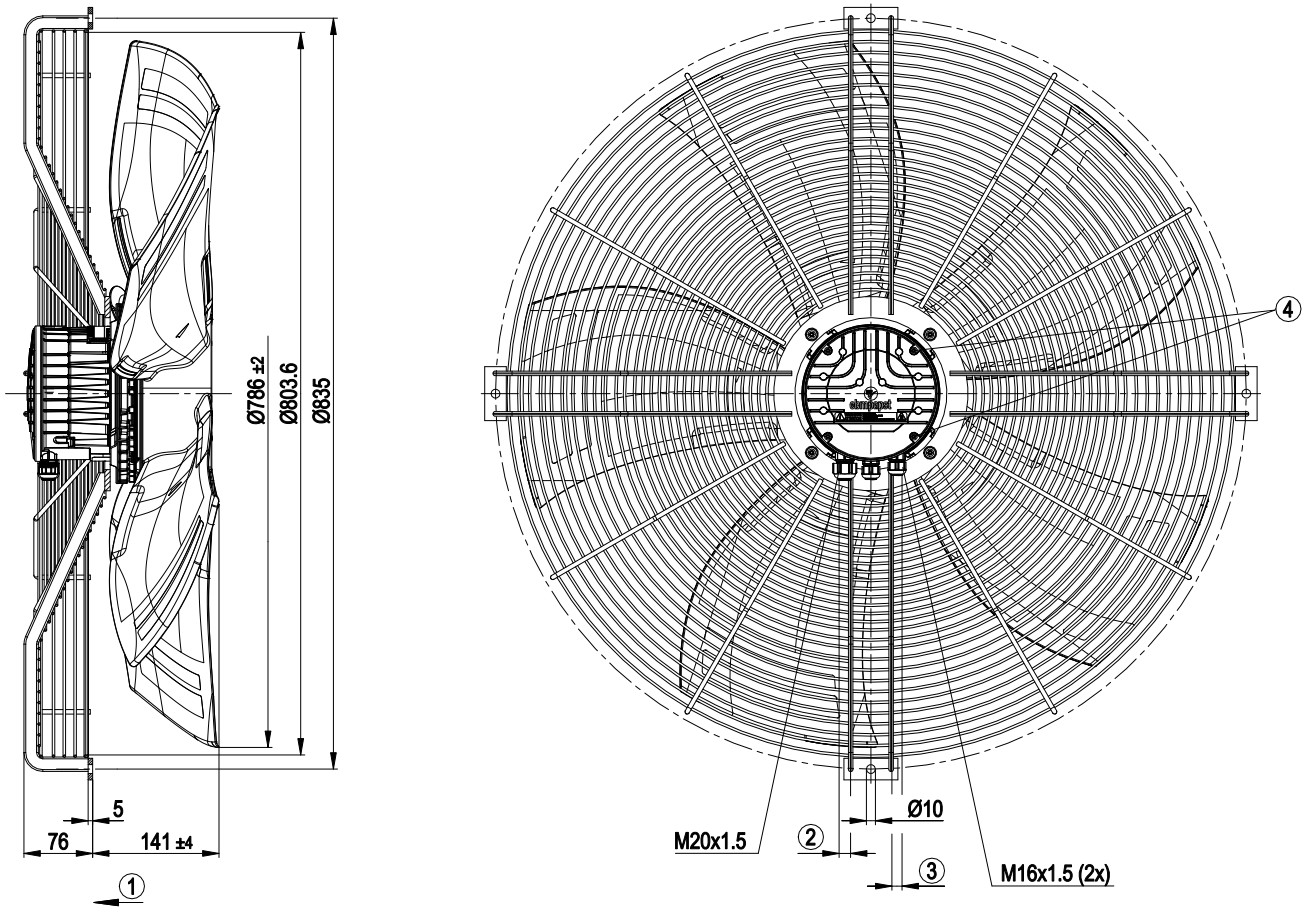
Product drawing



| | |
|---|------------------------------------------------------------------------------------------------------------------------------------------------------------------|
| 1 | Direction of air flow "V" |
| 2 | Cable diameter min. 8 mm, max. 12 mm, tightening torque 1.8±0.3 Nm (use the provided seal) Cable diameter min. 4 mm, max. 10 mm, tightening torque 1.8±0.3 Nm |
| 3 | Cable diameter min. 6 mm, max. 10 mm, tightening torque 1.8±0.3 Nm (use the provided seal) Cable diameter min. 4 mm, max. 7 mm, tightening torque 1.8±0.3 Nm |
| 4 | Tightening torque 1.5±0.2 Nm |



EC axial fan - HyBlade

sickled blades (S series)

with guard grille for full nozzle

Connection screen

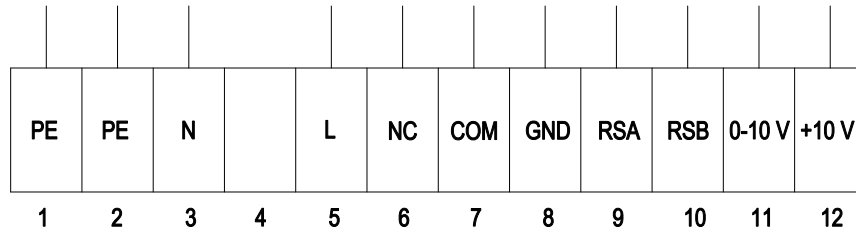

| No. | Conn. | Designation | Function / assignment |
|-----|--------|-------------|-----------------------------------------------------------------------------------------------------------------------------------------------------------------------------------------------|
| 1 | PE | PE | Protective earth |
| 2 | PE | PE | Protective earth |
| 3 | N | N | Power supply, neutral conductor |
| 4 | - | - | not used |
| 5 | L | L | Power supply, phase |
| 6 | NC | NC | Status relay, floating status contact, break for failure, contact rating 250 VAC / 2 A (AC1) min. 10 mA, basic insulation on mains side and reinforced insulation on control interface side |
| 7 | COM | COM | Status relay, floating status contact, common connection, contact rating 250 VAC / 2 A (AC1) / min. 10 mA, basic insulation on mains side and reinforced insulation on control interface side |
| 8 | GND | GND | Signal ground for control interface, SELV |
| 9 | RSA | RSA | RS-485 interface for MODBUS, RSA; SELV |
| 10 | RSB | RSB | RS-485 interface for MODBUS, RSB; SELV |
| 11 | 0-10 V | 0-10 V | Analogue input (set value) SELV, 0-10 V, Ri=100kΩ, parametrisable curve |
| 12 | +10 V | +10 V | Fixed voltage output 10 VDC, SELV, +10 V ±3%, max. 10 mA, short-circuit-proof, power supply for external devices (e.g. potentiometer) |

EC axial fan - HyBlade

sickled blades (S series)
with guard grille for full nozzle

Charts: Air flow 50 Hz

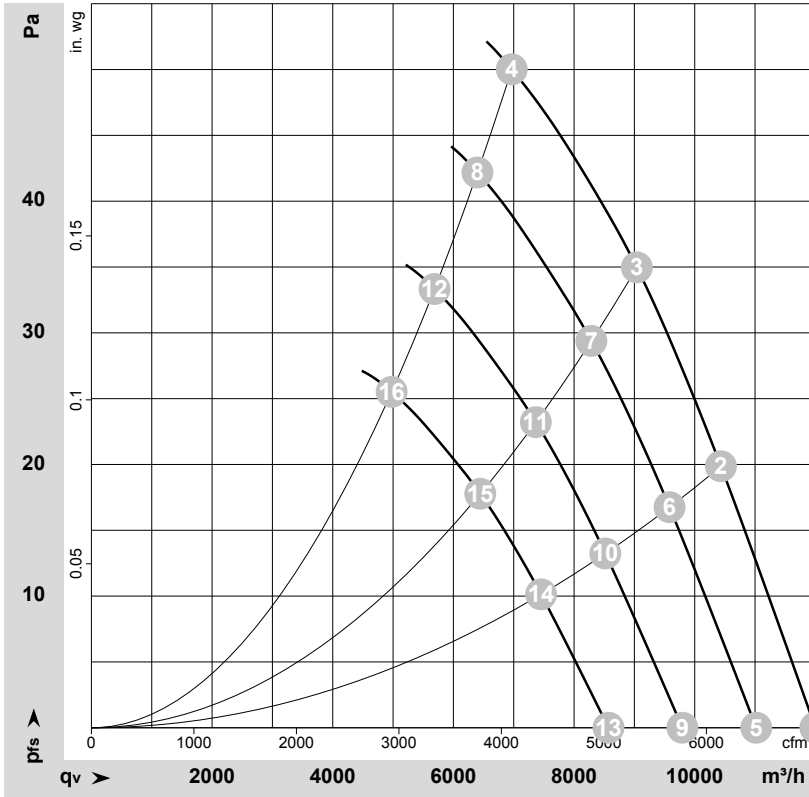

$\rho = 1.15 \text{ kg/m}^3 \pm 2 \%$

Measurement: LU-188695-1

Air performance measured as per ISO 5801 Installation category A. For detailed information on the measuring set-up, please contact ebmpapst. Suction-side noise levels: LwA measured as per ISO 13347 / LpA measured with 1m distance to fan axis. The values given are valid under the measuring conditions mentioned above and may vary according to the actual installation situation. With any deviation from the standard set-up, the specific values have to be checked and reviewed with the unit installed.

Measured values

| | Conn. | U | f | n | P _{ed} | I | LpA _{in} | LwA _{in} | LwA _{out} | q _v | p _{fs} | q _v | p _{fs} |
|----|-------|-----|----|-------------------|-----------------|------|-------------------|-------------------|--------------------|-------------------|-----------------|----------------|-----------------|
| | | V | Hz | min ⁻¹ | W | A | dB(A) | dB(A) | dB(A) | m ³ /h | Pa | cfm | in. wg |
| 1 | 1~ | 230 | 50 | 490 | 155 | 0.69 | 53 | 59 | 58 | 12000 | 0 | 7065 | 0.00 |
| 2 | 1~ | 230 | 50 | 490 | 190 | 0.84 | 51 | 57 | 56 | 10435 | 20 | 6140 | 0.08 |
| 3 | 1~ | 230 | 50 | 490 | 212 | 0.93 | 49 | 55 | 54 | 9040 | 35 | 5320 | 0.14 |
| 4 | 1~ | 230 | 50 | 490 | 240 | 1.10 | 51 | 59 | 58 | 6965 | 50 | 4100 | 0.20 |
| 5 | 1~ | 230 | 50 | 450 | 120 | 0.54 | 51 | 57 | 56 | 11020 | 0 | 6485 | 0.00 |
| 6 | 1~ | 230 | 50 | 450 | 147 | 0.65 | 49 | 54 | 54 | 9585 | 17 | 5640 | 0.07 |
| 7 | 1~ | 230 | 50 | 450 | 163 | 0.72 | 47 | 53 | 52 | 8285 | 30 | 4880 | 0.12 |
| 8 | 1~ | 230 | 50 | 450 | 183 | 0.80 | 49 | 57 | 56 | 6400 | 42 | 3765 | 0.17 |
| 9 | 1~ | 230 | 50 | 400 | 84 | 0.38 | 48 | 54 | 53 | 9795 | 0 | 5765 | 0.00 |
| 10 | 1~ | 230 | 50 | 400 | 103 | 0.46 | 46 | 51 | 51 | 8520 | 13 | 5015 | 0.05 |
| 11 | 1~ | 230 | 50 | 400 | 114 | 0.50 | 44 | 50 | 49 | 7365 | 23 | 4335 | 0.09 |
| 12 | 1~ | 230 | 50 | 400 | 129 | 0.56 | 46 | 54 | 53 | 5685 | 33 | 3345 | 0.13 |
| 13 | 1~ | 230 | 50 | 350 | 57 | 0.25 | 45 | 51 | 50 | 8570 | 0 | 5045 | 0.00 |
| 14 | 1~ | 230 | 50 | 350 | 69 | 0.31 | 42 | 48 | 47 | 7455 | 10 | 4385 | 0.04 |
| 15 | 1~ | 230 | 50 | 350 | 77 | 0.34 | 40 | 46 | 45 | 6445 | 18 | 3795 | 0.07 |
| 16 | 1~ | 230 | 50 | 350 | 86 | 0.38 | 43 | 50 | 50 | 4975 | 26 | 2930 | 0.10 |

Conn. = Connection · U = Supply voltage · f = Frequency · n = Speed (rpm) · P_{ed} = Power input · I = Current draw · LpA_{in} = Sound pressure level inlet side · LwA_{in} = Sound power level inlet side
LwA_{out} = Sound power level outlet side · q_v = Air flow · p_{fs} = Pressure increase