

S3G800-BS39-61

TRANE

EC axial fan - HyBlade

sickle-shaped blades (S series)

with guard grille for full nozzle

S3G800-BS39-61 ebmpapst Datasheet

sales@fansco.com

www.fansco.com

Limited partnership · Headquarters Mulfingen

Amtsgericht (court of registration) Stuttgart · HRA 590344

General partner Elektrobau Mulfingen GmbH · Headquarters Mulfingen

Amtsgericht (court of registration) Stuttgart · HRB 590142

Nominal data

Type	S3G800-BS39-61	
Motor	M3G150-FF	
Phase		3~
Nominal voltage	VAC	400
Nominal voltage range	VAC	380 .. 480
Frequency	Hz	50/60
Method of obtaining data		ml
Speed (rpm)	min ⁻¹	1020
Power consumption	W	1950
Current draw	A	3.0
Max. back pressure	Pa	80
Max. back pressure	in. wg	0.32
Min. ambient temperature	°C	-25
Max. ambient temperature	°C	70

ml = Max. load · me = Max. efficiency · fa = Free air · cs = Customer specification · ce = Customer equipment
Subject to change

Data according to Commission Regulation (EU) 327/2011 (EN 17166)

		Actual	Req. 2015			
01 Overall efficiency η_{es}	%	42.2	35.9	09 Power consumption P_{ed}	kW	2.28
02 Measurement category		A		09 Air flow q_v	m ³ /h	17150
03 Efficiency category		Static		09 Pressure increase p_{fs}	Pa	191
04 Efficiency grade N		46.3	40	10 Speed (rpm) n	min ⁻¹	1025
05 Variable speed drive		Yes		11 Specific ratio*		1.00

Data obtained at optimum efficiency level.
The ErP data is determined using a motor-impeller combination in a standardized measurement setup.

* Specific ratio = $1 + p_s / 100\,000\text{ Pa}$

LU-200297



S3G800-BS39-61

TRANE

EC axial fan - HyBlade

sickle-shaped blades (S series)

with guard grille for full nozzle

Technical description

Weight	30 kg
Size	800 mm
Motor size	150
Rotor surface	Painted black
Electronics housing material	Die-cast aluminum, painted black
Blade material	Sheet aluminum insert, sprayed with PP plastic
Guard grille material	Steel, coated with black plastic (RAL 9005)
Number of blades	5
Blade pitch	0°
Airflow direction	V
Direction of rotation	Clockwise, viewed toward rotor
Degree of protection	IP55
Insulation class	"F"
Moisture (F) / Environmental (H) protection class	H2
Max. permitted ambient temp. for motor (transport/storage)	+80 °C
Min. permitted ambient temp. for motor (transport/storage)	-40 °C
Installation position	Shaft horizontal or rotor on bottom
Condensation drainage holes	On rotor side
Mode	S1
Motor bearing	Ball bearing
Technical features	<ul style="list-style-type: none">- Output 10 VDC, max. 10 mA- Output 20 VDC, max. 50 mA- Output for slave 0-10 V- Operation and alarm display- Input for sensor 0-10 V or 4-20 mA- External 24 V input (parameter setting)- External release input- Alarm relay- Integrated PID controller- Motor current limitation- PFC, passive- RS-485 MODBUS-RTU- Soft start- EEPROM write cycles: 100,000 maximum- Control input 0-10 VDC / PWM- Control interface with SELV potential safely disconnected from the mains- Thermal overload protection for electronics/motor- Line undervoltage / phase failure detection
Touch current according to IEC 60990 (measuring circuit Fig. 4, TN system)	<= 3.5 mA
Electrical hookup	Connector with cable
Motor protection	Reverse polarity and locked-rotor protection
Protection class	I (with customer connection of protective earth)
Conformity with standards	EN 61800-5-1; CE
Approval	EAC



S3G800-BS39-61

TRANE

EC axial fan - HyBlade

sickle-shaped blades (S series)

with guard grille for full nozzle

Product drawing

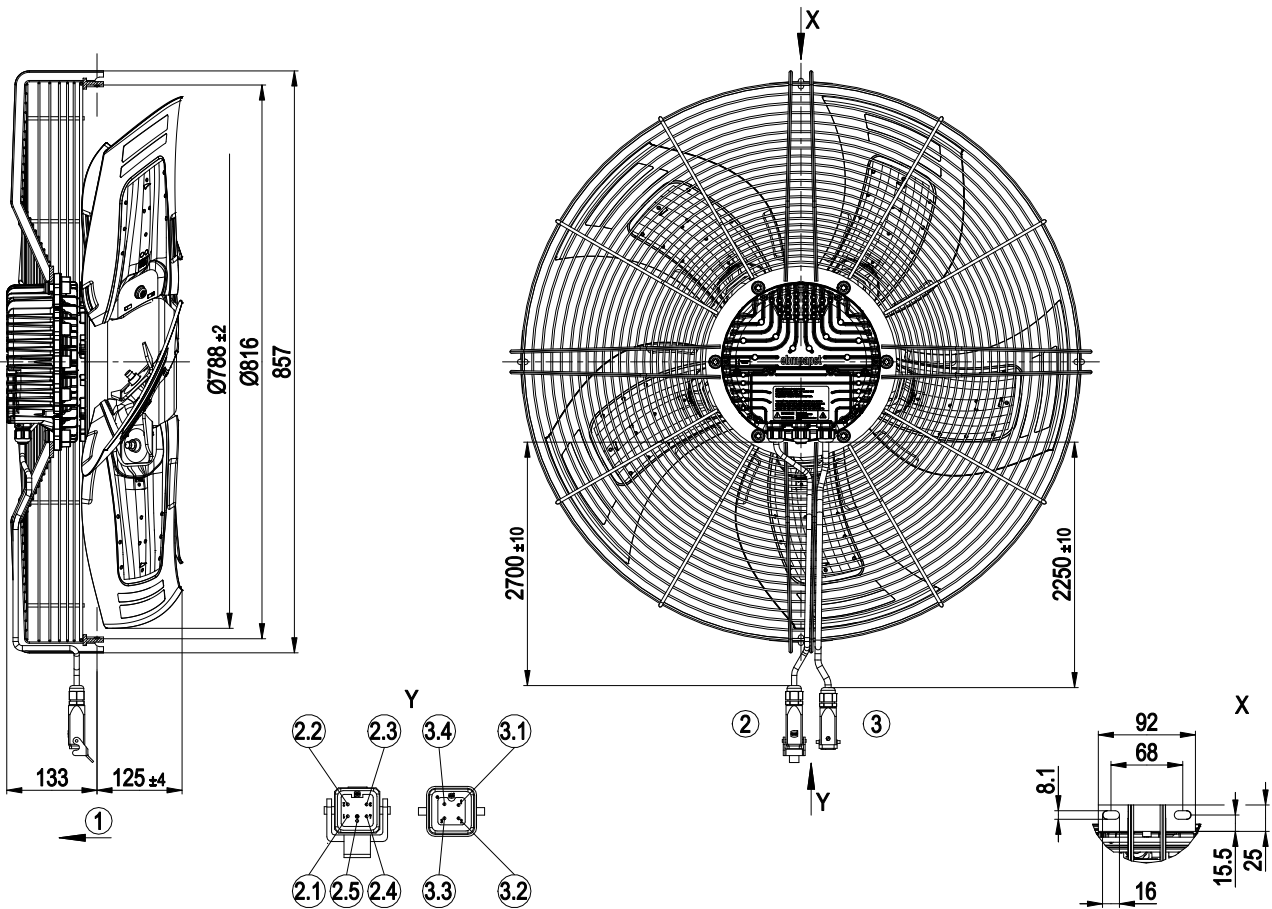

1	Airflow direction "V"
2	Cable Ölflex Heat 105 MC 4G 1.0 mm ² Connector housing WESTEC 7803.6231.1, 5-pole pin insert WESTEC 7204.6102.4
2.1	not used
2.2	Din1
2.3	Ain 1 U
2.4	GND
2.5	not used
3	Cable Ölflex Heat 105 MC 4G 1.5 mm ² Connector housing WESTEC 7803.6227.1, 4-pole pin insert WESTEC 7203.6101.0
3.1	L1
3.2	L2
3.3	L3
3.4	PE



EC axial fan - HyBlade

sickle-shaped blades (S series)

with guard grille for full nozzle

Connection diagram

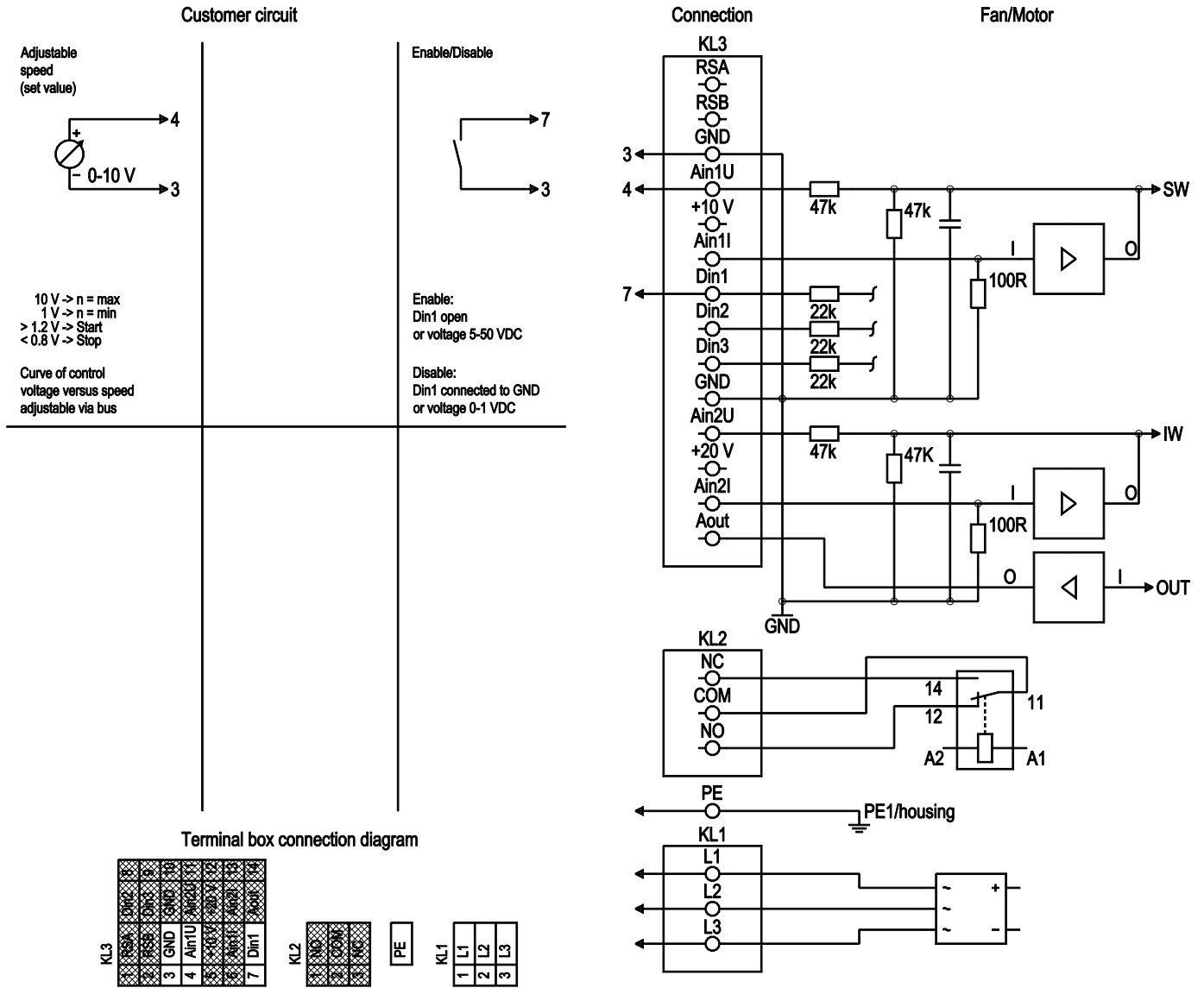

shaded gray => not brought out via leads

No.	Conn.	Designation	Function/assignment
KL 1	1	L1	Supply connection, power supply, phase, see nameplate for voltage range
KL 1	2	L2	Supply connection, power supply, phase, see nameplate for voltage range
KL 1	3	L3	Supply connection, power supply, phase, see nameplate for voltage range
PE		PE	Ground connection, PE connection
KL 2	1	NO	Status relay, floating status contact, make for failure
KL 2	2	COM	Status relay, floating status contact, changeover contact, common connection, contact rating, max. 250 VAC/2 A (AC1)/min. 10 mA
KL 2	3	NC	Status relay, floating status contact, break for failure
KL 3	1	RSA	Bus connection RS485, RSA, MODBUS-RTU; SELV
KL 3	2	RSB	Bus connection RS485, RSB, MODBUS-RTU; SELV
KL 3	3 / 10	GND	Reference ground for control interface, SELV



EC axial fan - HyBlade

sickle-shaped blades (S series)

with guard grille for full nozzle

No.	Conn.	Designation	Function/assignment
KL 3	4	Ain1 U	Analog input 1, set value: 0-10 V, $R_i = 100\text{ k}\Omega$, adjustable curve, only usable as alternative to input Ain1 I; SELV
KL 3	5	+ 10 V	Fixed voltage output 10 VDC, $+10\text{ V} \pm 3\%$, max. 10 mA, short-circuit-proof, power supply for external devices (e.g. pot); SELV
KL 3	6	Ain1 I	Analog input 1, set value: 4-20 mA, $R_i = 100\ \Omega$, adjustable curve, only usable as alternative to input Ain1 U; SELV
KL 3	7	Din1	Digital input 1: enable electronics, enable: pin open or applied voltage 5-50 VDC disable: bridge to GND or applied voltage $< 1\text{ VDC}$ reset function: triggers software reset after a level change to $< 1\text{ VDC}$; SELV
KL 3	8	Din2	Digital input 2: Switching parameter sets 1/2, according to EEPROM setting, the valid or used parameter set can be selected via bus or via digital input DIN2. Parameter set 1: pin open or applied voltage 5-50 VDC Parameter set 2: bridge to GND or applied voltage $< 1\text{ VDC}$; SELV
KL 3	9	Din3	Digital input 3: Direction of action of integrated controller, according to EEPROM setting, the direction of action of the integrated controller can be selected as normal/inverse via bus or digital input Normal: Pin open or applied voltage 5-50 VDC Inverse: Bridge to GND or applied voltage $< 1\text{ VDC}$; SELV
KL 3	11	Ain2 U	Analog input 2, measured value: 0-10 V, $R_i = 100\text{ k}\Omega$, adjustable curve, only usable as alternative to input Ain2 I; SELV
KL 3	12	+ 20 V	Fixed voltage output 20 VDC, $+20\text{ V} +25\%/ -10\%$, max. 50 mA, short-circuit-proof, power supply for external devices (e.g. sensors); SELV Alternatively: +24 VDC input for parameterization without line voltage
KL 3	13	Ain2 I	Analog input 2, measured value: 4-20 mA, $R_i = 100\ \Omega$, adjustable curve, only usable as alternative to input Ain2 U; SELV
KL 3	14	Aout	Analog output 0-10 V, max. 5 mA, output of current motor modulation level; adjustable curve; SELV



EC axial fan - HyBlade

sickle-shaped blades (S series)

with guard grille for full nozzle

Curves: Air performance 50 Hz

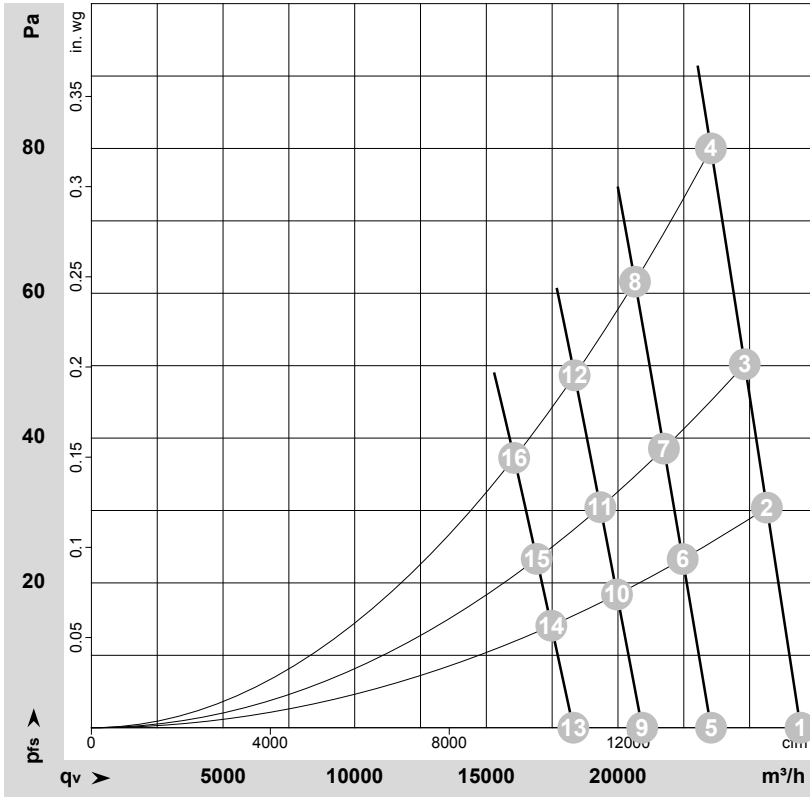

$\rho = 1.15 \text{ kg/m}^3 \pm 2 \%$

Measurement: LU-163024-1

Air performance measured according to ISO 5801 installation category A. For detailed information on the measurement setup, contact ebmpapst. Intake sound level: Sound power level according to ISO 13347 / sound pressure level measured at 1 m distance from fan axis. The values given are valid under the specified measuring conditions and may vary due to conditions of installation. For deviations from the standard configuration, the parameters have to be checked on the installed unit.

Measured values

	Wired	U	f	n	P _{ed}	I	LpA _{in}	LwA _{in}	LwA _{out}	q _v	P _{fs}	q _v	P _{fs}
		V	Hz	min ⁻¹	W	A	dB(A)	dB(A)	dB(A)	m ³ /h	Pa	cfm	in. wg
1	3~	400	50	1020	1694	2.64	68	76	76	26935	0	15855	0.00
2	3~	400	50	1020	1803	2.80	68	75	76	25655	30	15100	0.12
3	3~	400	50	1020	1875	2.91	68	75	75	24815	50	14605	0.20
4	3~	400	50	1020	1950	3.00	68	75	75	23530	80	13850	0.32
5	3~	400	50	900	1130	1.76	65	72	73	23535	0	13850	0.00
6	3~	400	50	900	1210	1.88	65	72	72	22460	23	13220	0.09
7	3~	400	50	900	1263	1.96	65	72	72	21745	39	12800	0.16
8	3~	400	50	900	1340	2.07	65	72	72	20645	62	12150	0.25
9	3~	400	50	800	794	1.24	62	69	70	20920	0	12315	0.00
10	3~	400	50	800	850	1.32	62	69	69	19965	18	11750	0.07
11	3~	400	50	800	887	1.37	62	69	69	19330	31	11375	0.12
12	3~	400	50	800	941	1.46	62	69	69	18350	49	10800	0.20
13	3~	400	50	700	532	0.83	59	66	67	18305	0	10775	0.00
14	3~	400	50	700	569	0.88	59	66	66	17470	14	10280	0.06
15	3~	400	50	700	594	0.92	59	66	66	16915	24	9955	0.10
16	3~	400	50	700	631	0.98	59	66	65	16060	37	9450	0.15

Wired = Wiring · U = Voltage · f = Frequency · n = Speed (rpm) · P_{ed} = Power consumption · I = Current draw · LpA_{in} = Sound pressure level intake side · LwA_{in} = Sound power level intake side
LwA_{out} = Sound power level outlet side · q_v = Air flow · P_{fs} = Pressure increase

