

S3G800-BO84-01/F02 ebmpapst Datasheet

sales@fansco.com

www.fansco.com

Limited partnership · Headquarters Muldingen
County court Stuttgart · HRA 590344General partner Elektrobau Muldingen GmbH · Headquarters Muldingen
County court Stuttgart · HRB 590142

Nominal data

Type	S3G800-BO84-01/F02	
Motor	M3G112-IA	
Phase		3~
Nominal voltage	VAC	400
Nominal voltage range	VAC	380 .. 480
Frequency	Hz	50/60
Type of data definition		ml
Speed	min ⁻¹	735
Power input	W	835
Current draw	A	1.4
Min. ambient temperature	°C	-25
Max. ambient temperature	°C	60

ml = Max. load · me = Max. efficiency · fa = Running at free air · cs = Customer specs · cu = Customer unit
Subject to alterations

Data according to ErP directive

Installation category	A
Efficiency category	Static
Variable speed drive	Yes
Specific ratio*	1.00

* Specific ratio = $1 + p_{fs} / 100\,000\text{ Pa}$

		Actual	Request 2013	Request 2015
Overall efficiency η_{es}	%	44.2	29	33
Efficiency grade N		51.2	36	40
Power input P_{ed}	kW	0.78		
Air flow q_v	m ³ /h	12095		
Pressure increase p_{fs}	Pa	95		
Speed n	min ⁻¹	740		

Data definition with optimum efficiency. LU-117968
The ErP data is determined using a motor-impeller combination in a standardised measurement configuration.



Technical features

Mass	18.2 kg
Size	800 mm
Surface of rotor	Coated in black
Material of electronics housing	Die-cast aluminium
Material of blades	Press-fitted sheet steel blank, sprayed with PP plastic
Material of guard grille	Steel, coated in black plastic (RAL9005)
Number of blades	5
Direction of air flow	"V"
Direction of rotation	Clockwise, seen on rotor
Type of protection	IP 54
Insulation class	"B"
Humidity class	F4-1
Max. permissible ambient motor temp. (transp./ storage)	Max. +80 °C
Min. permissible ambient motor temp. (transp./storage)	Min. -40 °C
Mounting position	Shaft horizontal or rotor on bottom
Condensate discharge holes	Rotor-side
Operation mode	S1
Motor bearing	Ball bearing
Technical features	<ul style="list-style-type: none"> - Output 10 VDC, max. 10 mA - Alarm relay - Integrated PID controller - Motor current limit - PFC, passive - Soft start - Control input 0-10 VDC / PWM - Control interface with SELV potential safely disconnected from the mains - Over-temperature protected electronics / motor - Line undervoltage / phase failure detection
EMC interference immunity	Acc. to EN 61000-6-2 (industrial environment)
EMC harmonics	Acc. to EN 61000-3-2/3
EMC interference emission	Acc. to EN 61000-6-4 (industrial environment)
Touch current acc. IEC 60990 (measuring network Fig. 4, TN system)	<= 3.5 mA
Motor protection	Thermal overload protector (TOP) wired internally
Cable exit	Variable
Protection class	I (if protective earth is connected by customer)
Product conforming to standard	EN 61800-5-1; CE
Approval	CCC; EAC

EC axial fan - HyBlade®

sickled blades (S series), single inlet
with guard grille for full nozzle

Product drawing

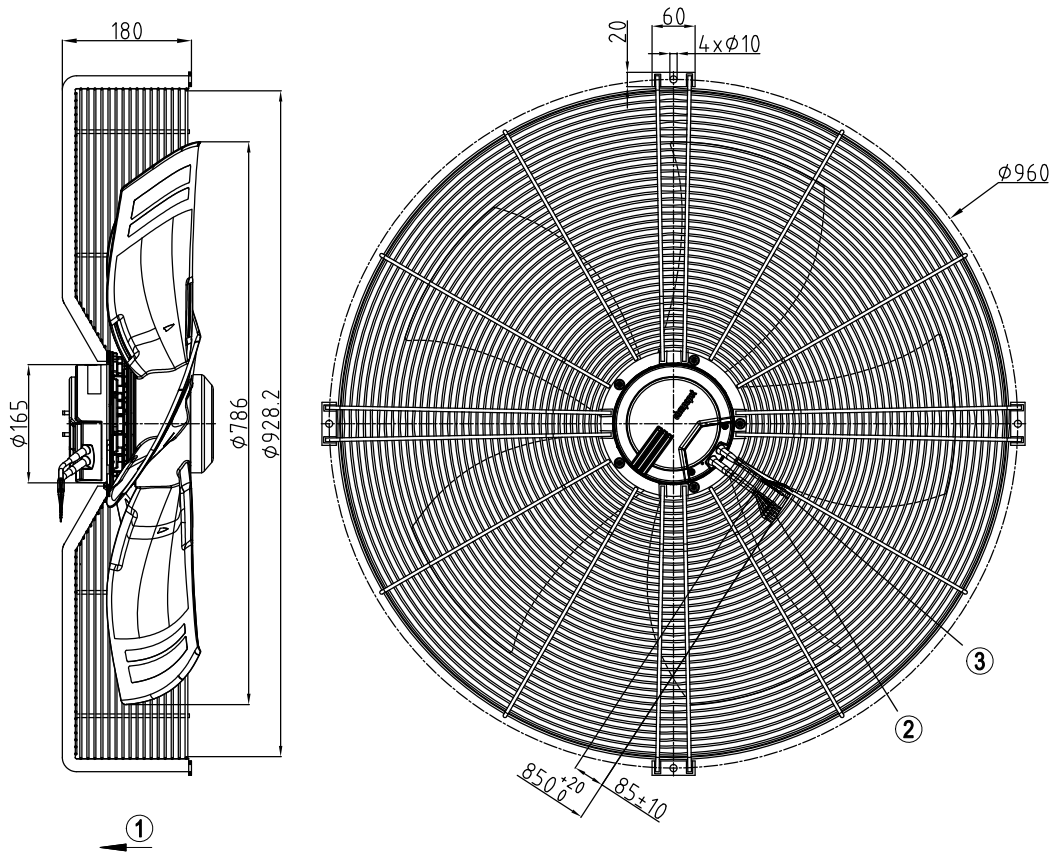

1	Direction of air flow "V"
2	Connection line PVC AWG18, 6x crimped core-end sleeves
3	Connection line PVC AWG22, 3x crimped core-end sleeves



EC axial fan - HyBlade®

sickled blades (S series), single inlet
with guard grille for full nozzle

Connection screen

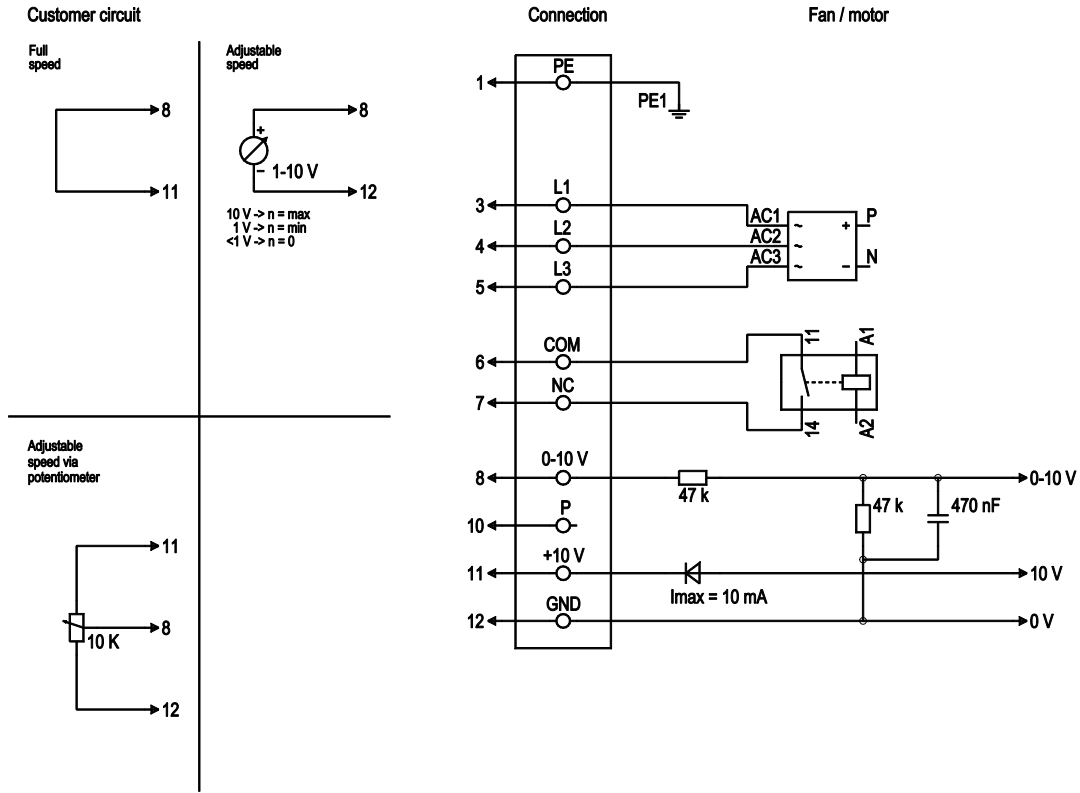

No.	Conn.	Designation	Colour	Function / assignment
1	1	PE	green/yellow	Ground wire
1	3	L1	black	Supply voltage, 50/60 Hz
1	4	L2	black	Supply voltage, 50/60 Hz
1	5	L3	black	Supply voltage, 50/60 Hz
1	6	COM	white 1	Floating status message contact, normally closed connection (2 A, max. 250 VAC, min. 10 mA, AC1)
1	7	NC	white 2	Floating status message contact, normally closed connection
2	8	0-10 V	yellow	Control input, set value 0-10 VDC, impedance 100 kΩ, SELV
2	10	P	orange	Do not use
2	11	+10 V	red	Voltage output 10 VDC (+/-3%), max. 10 mA, supply voltage for external devices (e.g. potentiometer), SELV
2	12	GND	blue	Reference mass for control interface, SELV



Charts: Air flow 50 Hz

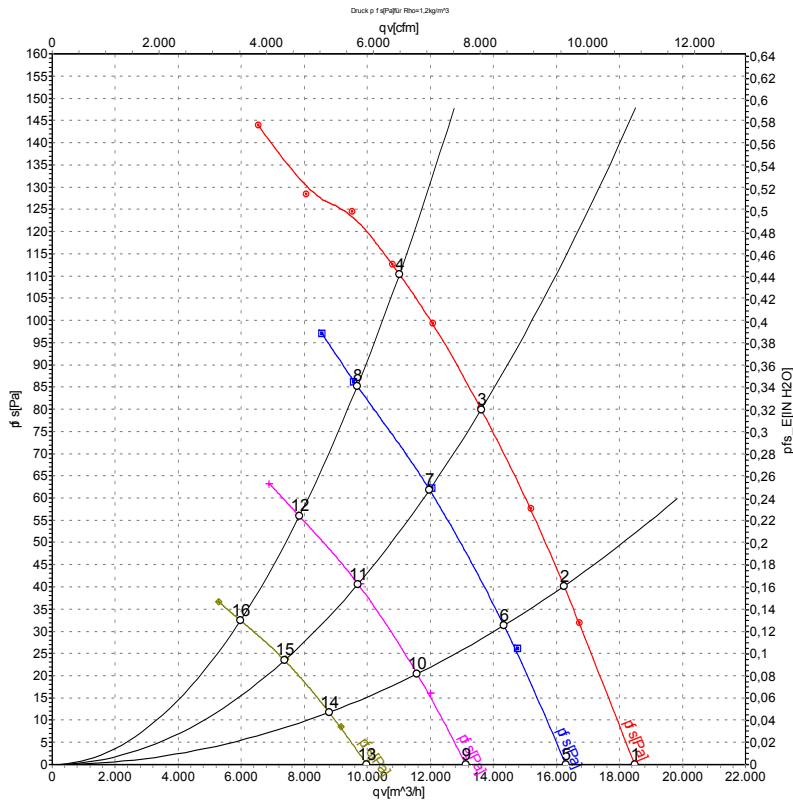

Air performance measured as per ISO 5801 Installation category A. For detailed information on the measuring set-up, please contact ebm-papst. Suction-side noise levels: LwA measured as per ISO 13347 / LpA measured with 1m distance to fan axis. The values given are valid under the measuring conditions mentioned above and may vary according to the actual installation situation. With any deviation from the standard set-up, the specific values have to be checked and reviewed with the unit installed.

Measured values

	U	f	n	P _{ed}	I	LpA _{in}	LwA _{in}	LwA _{out}	qv	p _{fs}
	V	Hz	min ⁻¹	W	A	dB(A)	dB(A)	dB(A)	m ³ /h	Pa
1	400	50	735	514	0.87	63	70	70	18480	0
2	400	50	735	632	1.04	59	66	65	16240	40
3	400	50	735	732	1.20	57	64	64	13610	80
4	400	50	735	835	1.40	62	70	69	11020	110
5	400	50	650	338	0.66	59	66	66	16290	0
6	400	50	650	398	0.77	57	63	63	14330	32
7	400	50	650	476	0.86	54	61	60	11970	63
8	400	50	650	521	0.89	58	66	66	9685	85
9	400	50	525	185	0.39	54	61	60	13120	0
10	400	50	525	223	0.46	52	58	58	11580	21
11	400	50	525	253	0.51	49	56	55	9705	41
12	400	50	525	276	0.55	53	60	60	7845	56
13	400	50	400	90	0.23	48	54	54	9985	0
14	400	50	400	107	0.26	46	52	52	8785	12
15	400	50	400	120	0.28	43	50	50	7375	24
16	400	50	400	127	0.29	45	52	52	5975	32

U = Supply voltage · f = Frequency · n = Speed · P_{ed} = Power input · I = Current draw · LpA_{in} = Sound pressure level inlet side · LwA_{in} = Sound power level inlet side · LwA_{out} = Sound power level outlet side
qv = Air flow · p_{fs} = Pressure increase

