

EC axial fan - HyBlade

sickle-shaped blades (S series)

with guard grille for full nozzle

S3G710-CZ04-08 ebmpapst Datasheet

sales@fansco.com

www.fansco.com

Limited partnership · Headquarters Muldingen

Amtsgericht (court of registration) Stuttgart · HRA 590344

General partner Elektrobau Muldingen GmbH · Headquarters Muldingen

Amtsgericht (court of registration) Stuttgart · HRB 590142

Nominal data

Type	S3G710-CZ04-08	
Motor	M3G150-NA	
Phase		3~
Nominal voltage	VAC	400
Nominal voltage range	VAC	380 .. 480
Frequency	Hz	50/60
Method of obtaining data		ml
Speed (rpm)	min ⁻¹	1630
Power consumption	W	4900
Current draw	A	7.5
Max. back pressure	Pa	406
Max. back pressure	in. wg	1.63
Min. ambient temperature	°C	-40
Max. ambient temperature	°C	40

ml = Max. load · me = Max. efficiency · fa = Free air · cs = Customer specification · ce = Customer equipment
Subject to change

Data according to Commission Regulation (EU) 327/2011

		Actual	Req. 2015		
01 Overall efficiency η_{es}	%	44.3	38	09 Power consumption P_{ed}	kW
02 Measurement category		A		09 Air flow q_v	m ³ /h
03 Efficiency category		Static		09 Pressure increase p_{fs}	Pa
04 Efficiency grade N		46.3	40	10 Speed (rpm) n	min ⁻¹
05 Variable speed drive		Yes		11 Specific ratio*	
					1.01

Data obtained at optimum efficiency level.

The ErP data is determined using a motor-impeller combination in a standardized measurement setup.

* Specific ratio = $1 + p_s / 100\,000\text{ Pa}$

LU-131215



EC axial fan - HyBlade

sickle-shaped blades (S series)

with guard grille for full nozzle

Technical description

Weight	37 kg
Size	710 mm
Motor size	150
Rotor surface	Painted black
Electronics housing material	Die-cast aluminum, painted black
Blade material	Sheet aluminum insert, sprayed with PP plastic
Guard grille material	Steel, coated with black plastic (RAL 9005)
Number of blades	5
Blade pitch	-5°
Airflow direction	V
Direction of rotation	Clockwise, viewed toward rotor
Degree of protection	IP55
Insulation class	"F"
Moisture (F) / Environmental (H) protection class	H2
Ambient temperature note	As fan only suitable for use with industrial evaporators
Max. permitted ambient temp. for motor (transport/storage)	+80 °C
Min. permitted ambient temp. for motor (transport/storage)	-40 °C
Installation position	Shaft horizontal or rotor on bottom; rotor on top on request
Condensation drainage holes	On rotor side
Mode	S1
Motor mounting	Ball bearing
Technical features	<ul style="list-style-type: none"> - Output 10 VDC, max. 10 mA - Output for slave 0-10 V - External 24 V input (parameter setting) - External release input - Alarm relay - Integrated PID controller - Power limiter - Motor current limitation - PFC, passive - RS-485 MODBUS-RTU - Soft start - Control input 0-10 VDC - Control interface with SELV potential safely disconnected from the mains - Thermal overload protection for electronics/motor - Line undervoltage / phase failure detection
Touch current according to IEC 60990 (measuring circuit Fig. 4, TN system)	<= 3.5 mA
Electrical hookup	Terminal box
Motor protection	Reverse polarity and locked-rotor protection
Protection class	I (with customer connection of protective earth)
Conformity with standards	EN 61800-5-1; CE
Approval	EAC; UL 1004-7 + 60730; CSA C22.2 No. 77 + CAN/CSA-E60730-1



EC axial fan - HyBlade

sickle-shaped blades (S series)

with guard grille for full nozzle

Product drawing

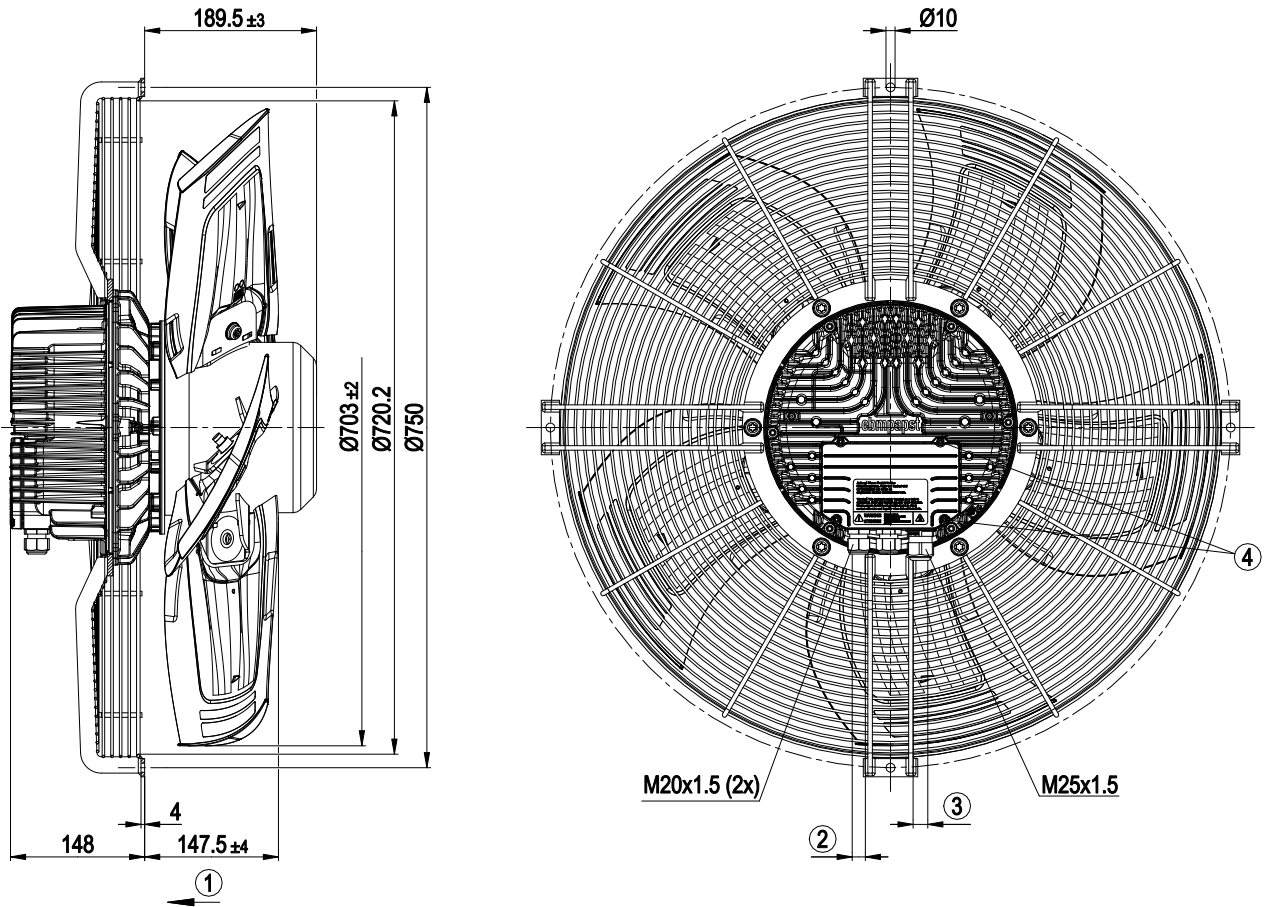

1	Airflow direction "V"
2	Cable diameter min. 4 mm, max. 10 mm, tightening torque 4 ± 0.6 Nm
3	Cable diameter min. 9 mm, max. 16 mm, tightening torque 6 ± 0.9 Nm
4	Tightening torque 3.5 ± 0.5 Nm



EC axial fan - HyBlade

sickle-shaped blades (S series)

with guard grille for full nozzle

Connection diagram

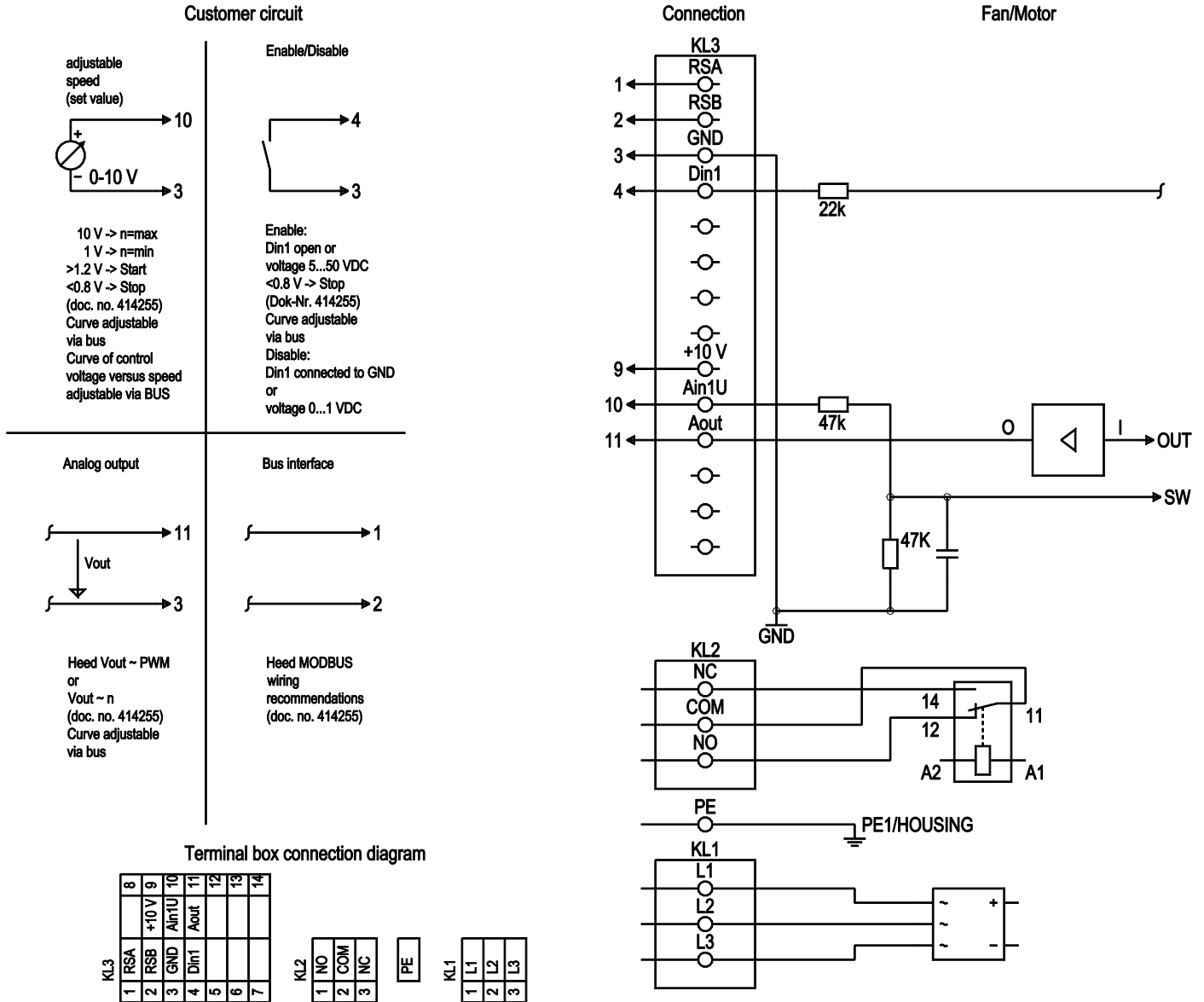

No.	Conn.	Designation	Function/assignment
KL 1	1, 2, 3	L1, L2, L3	Power supply, phase, see nameplate for voltage range
PE	PE	PE	Protective earth
KL2	1	NO	Status relay, floating status contact, option 1: make for failure, option 2: make for error for run monitor
KL2	2	COM	Status relay, floating status contact, common connection, contact rating 250 VAC / 2 A (AC1) / min. 10 mA; basic insulation on supply side and reinforced insulation on control interface side
KL2	3	NC	Status relay, floating status contact, option 1: break for failure, option 2: break for error message for run monitor
KL 3	1	RSA	RS485 interface for MODBUS, RSA; SELV
KL 3	2	RSB	RS485 interface for MODBUS, RSB; SELV
KL 3	3	GND	Reference ground for control interface; SELV
KL 3	4	Din1	Digital input 1: enable electronics, enable: pin open or applied voltage 5-50 VDC d voltage < 1 VDC reset after 1 s level change to < 1 VDC; SELV



EC axial fan - HyBlade

sickle-shaped blades (S series)

with guard grille for full nozzle

No.	Conn.	Designation	Function/assignment
KL 3	-	-	-
KL 3	-	-	-
KL3	-	-	-
KL3	-	-	-
KL 3	9	10 V / max. 10 mA	Voltage output, power supply for external devices (e.g. potentiometers), SELV
KL 3	10	Ain1 U	Analog input 1, set value: 0-10 V, Ri = 100 kΩ, adjustable curve; SELV
KL 3	11	Aout	Analog output 0-10 VDC, max. 5 mA, output of current motor modulation level / motor speed adjustable curve; SELV
KL 3	-	-	-
KL 3	-	-	-
KL 3	-	-	-



EC axial fan - HyBlade

sickle-shaped blades (S series)

with guard grille for full nozzle

Curves: Air performance 50 Hz

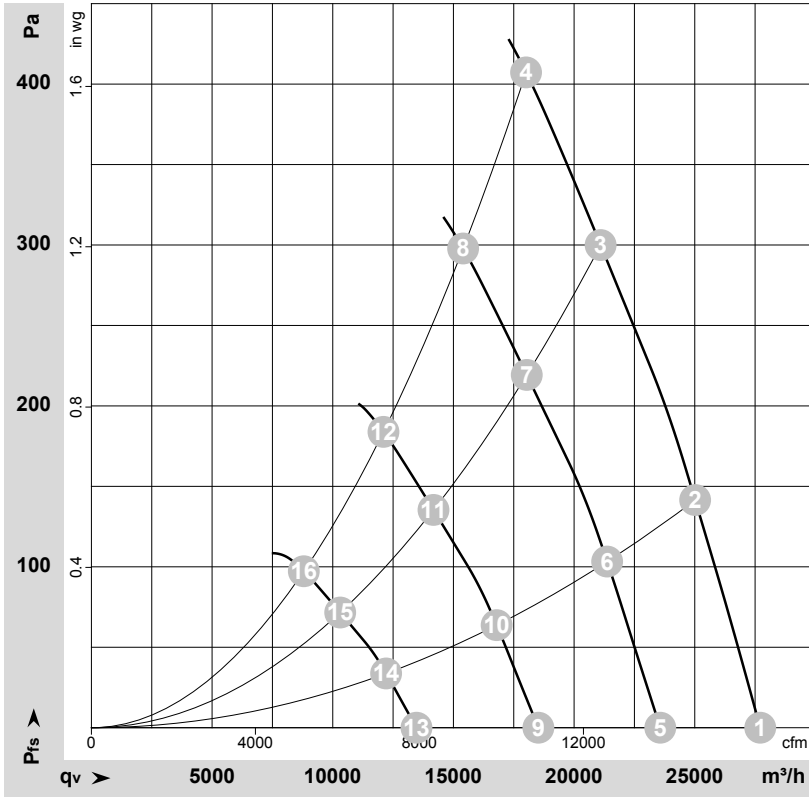

$\rho = 1.15 \text{ kg/m}^3 \pm 2 \%$

Measurement: LU-131215-1

Air performance measured according to ISO 5801 installation category A. For detailed information on the measurement setup, contact ebmpapst. Intake sound level: Sound power level according to ISO 13347 / sound pressure level measured at 1 m distance from fan axis. The values given are valid under the specified measuring conditions and may vary due to conditions of installation. For deviations from the standard configuration, the parameters have to be checked on the installed unit.

Measured values

	U	f	n	P _{ed}	I	LpA _{in}	LwA _{in}	LwA _{out}	q _v	P _{fs}	q _v	P _{fs}
	V	Hz	min ⁻¹	W	A	dB(A)	dB(A)	dB(A)	m ³ /h	Pa	cfm	in. wg
1	400	50	1630	3565	5.55	77	85	86	27715	0	16310	0.00
2	400	50	1630	4095	6.33	77	84	85	25015	140	14725	0.56
3	400	50	1630	4625	7.12	82	89	88	21100	300	12420	1.20
4	400	50	1630	4900	7.50	85	92	91	18010	406	10600	1.63
5	400	50	1400	2194	3.41	73	81	82	23570	0	13875	0.00
6	400	50	1400	2555	3.95	73	80	81	21370	103	12580	0.41
7	400	50	1400	2890	4.45	78	85	84	18040	219	10615	0.88
8	400	50	1400	3016	4.63	81	88	87	15400	299	9065	1.20
9	400	50	1100	1064	1.66	67	75	76	18520	0	10900	0.00
10	400	50	1100	1239	1.91	67	74	75	16790	64	9885	0.26
11	400	50	1100	1402	2.16	72	79	78	14175	135	8345	0.54
12	400	50	1100	1463	2.24	75	82	81	12100	185	7120	0.74
13	400	50	800	409	0.64	59	67	68	13470	0	7930	0.00
14	400	50	800	477	0.74	59	66	67	12210	34	7185	0.14
15	400	50	800	539	0.83	64	70	70	10310	72	6065	0.29
16	400	50	800	563	0.86	67	74	73	8800	98	5180	0.39

U = Power supply · f = Frequency · n = Speed (rpm) · P_{ed} = Power consumption · I = Current draw · LpA_{in} = Sound pressure level intake side · LwA_{in} = Sound power level intake side
 LwA_{out} = Sound power level outlet side · q_v = Air flow · P_{fs} = Pressure increase

