

# EC axial fan - HyBlade

sickle-shaped blades (S series)

with guard grille for full nozzle

S3G630-CU29-11 ebmpapst Datasheet

[sales@fansco.com](mailto:sales@fansco.com)

[www.fansco.com](http://www.fansco.com)

Limited partnership · Headquarters Mulfingen

Amtsgericht (court of registration) Stuttgart · HRA 590344

General partner Elektrobau Mulfingen GmbH · Headquarters Mulfingen

Amtsgericht (court of registration) Stuttgart · HRB 590142

## Nominal data

Type	S3G630-CU29-11	
Motor	M3G150-IF	
Phase		3~
Nominal voltage	VAC	200
Nominal voltage range	VAC	200 .. 240
Frequency	Hz	50/60
Method of obtaining data		ml
Speed (rpm)	min <sup>-1</sup>	1450
Power consumption	W	2950
Current draw	A	8.9
Max. back pressure	Pa	270
Max. back pressure	inH <sub>2</sub> O	1.08
Min. ambient temperature	°C	-25
Max. ambient temperature	°C	60

ml = Max. load · me = Max. efficiency · fa = Free air · cs = Customer specification · ce = Customer equipment  
Subject to change



# EC axial fan - HyBlade

sickle-shaped blades (S series)

with guard grille for full nozzle

## Technical description

Weight	31 kg
Fan size	630 mm
Rotor surface	Painted black
Electronics housing material	Die-cast aluminum, painted black
Blade material	Sheet aluminum insert, sprayed with PP plastic
Guard grille material	Steel, coated with black plastic (RAL 9005)
Number of blades	5
Blade pitch	0°
Airflow direction	"V"
Direction of rotation	Clockwise, viewed toward rotor
Degree of protection	IP55
Insulation class	"F"
Moisture (F) / Environmental (H) protection class	F4-1
Max. permitted ambient temp. for motor (transport/storage)	+ 80 °C
Min. permitted ambient temp. for motor (transport/storage)	- 40 °C
Installation position	Shaft horizontal or rotor on bottom; rotor on top on request
Condensation drainage holes	On rotor side
Mode	S1
Motor bearing	Ball bearing
Technical features	<ul style="list-style-type: none"> <li>- Output 10 VDC, max. 10 mA</li> <li>- Output 20 VDC, max. 50 mA</li> <li>- Output for slave 0-10 V</li> <li>- Input for sensor 0-10 V or 4-20 mA</li> <li>- External 24 V input (parameter setting)</li> <li>- External release input</li> <li>- Alarm relay</li> <li>- Integrated PID controller</li> <li>- Motor current limitation</li> <li>- PFC, passive</li> <li>- RS-485 MODBUS-RTU</li> <li>- Soft start</li> <li>- Control input 0-10 VDC / PWM</li> <li>- Control interface with SELV potential safely disconnected from the mains</li> <li>- Thermal overload protection for electronics/motor</li> <li>- Line undervoltage / phase failure detection</li> </ul>
EMC immunity to interference	According to EN 61000-6-2 (industrial environment)
EMC interference emission	According to EN 61000-6-4 (industrial environment)
Touch current according to IEC 60990 (measuring circuit Fig. 4, TN system)	<= 3.5 mA
Electrical hookup	Via terminal box
Motor protection	Reverse polarity and locked-rotor protection
Protection class	I (with customer connection of protective earth)
Conformity with standards	EN 61800-5-1; CE
Approval	C22.2 No.77 + CAN/CSA-E60730-1; UL 1004-7 + 60730



# EC axial fan - HyBlade

sickle-shaped blades (S series)

with guard grille for full nozzle

## Product drawing

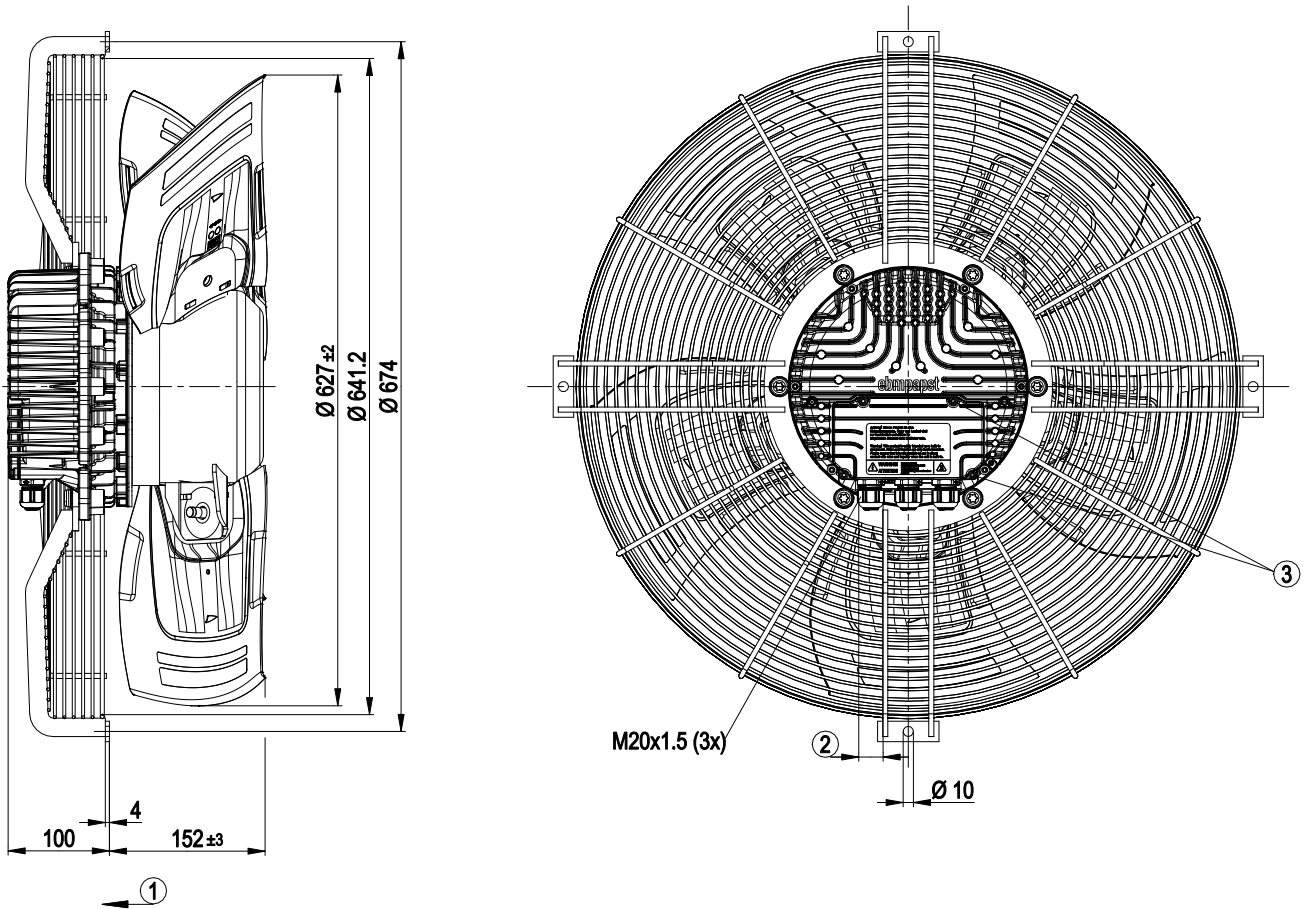

1	Direction of air flow "V"
2	Cable diameter min. 4 mm; max. 10 mm; tightening torque 4±0.6 Nm
3	Tightening torque 3.5±0.5 Nm



# EC axial fan - HyBlade

sickle-shaped blades (S series)

with guard grille for full nozzle

## Connection diagram

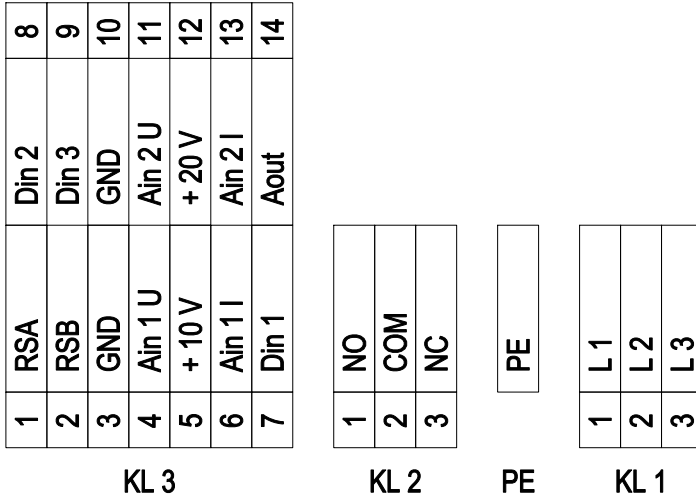

No.	Conn.	Designation	Function/assignment
KL 1	1	L1	Supply connection, power supply 3-phase 200-240 VAC, 50/60 Hz
KL 1	2	L2	Supply connection, power supply 3-phase 200-240 VAC, 50/60 Hz
KL 1	3	L3	Supply connection, power supply 3-phase 200-240 VAC, 50/60 Hz
PE		PE	Ground connection, PE connection
KL 2	1	NO	Status relay, floating status contact, make for failure
KL2	2	COM	Status relay, floating status contact; changeover contact; common connection; contact rating 250 VAC / max. 2 A (AC1) / min. 10 mA
KL2	3	NC	Status relay, floating status contact, break for failure
KL 3	1	RSA	Bus connection RS485, RSA, MODBUS-RTU; SELV
KL 3	2	RSB	Bus connection RS485, RSB, MODBUS-RTU; SELV
KL 3	3 / 10	GND	Reference ground for control interface; SELV
KL 3	4	Ain1 U	Analog input 1, set value: 0-10 V, Ri = 100 kΩ, adjustable curve, only usable as alternative to input Ain1I; SELV
KL 3	5	+ 10 V	Fixed voltage output 10 VDC, +10 V ±3%, max. 10 mA, short-circuit-proof power supply for external devices (e.g. pot); SELV
KL 3	6	Ain1 I	Analog input 1, set value: 4-20 mA, Ri = 100 Ω, adjustable curve, only usable as alternative to input Ain1U; SELV
KL 3	7	Din1	Digital input 1: enable electronics, enable: pin open or applied voltage 5-50 VDC disable: bridge to GND or applied voltage < 1 VDC reset function: triggers software reset after a level change to < 1 VDC; SELV
KL 3	8	Din2	Digital input 2: Switching parameter sets 1/2, according to EEPROM setting, the valid or used parameter set can be selected via bus or via digital input DIN2. Parameter set 1: pin open or applied voltage 5-50 VDC Parameter set 2: bridge to GND or applied voltage < 1 VDC; SELV
KL 3	9	Din3	Digital input 3: according to EEPROM setting, the integrated controller's direction of action can be selected as normal/inverse via bus or digital input normal: pin open or applied voltage 5-50 VDC inverse: bridge to GND or applied voltage < 1 VDC; SELV
KL 3	11	Ain2 U	Analog input 2, measured value: 0-10 V, Ri = 100 kΩ, adjustable curve, only usable as alternative to input Ain2I; SELV
KL 3	12	+ 20 V	Fixed voltage output 20 VDC, +20 V ±5/-10%, max. 50 mA, short-circuit-proof power supply for external devices (e.g. sensors); SELV



## EC axial fan - HyBlade

sickle-shaped blades (S series)

with guard grille for full nozzle

No.	Conn.	Designation	Function/assignment
KL 3	13	Ain2 I	Analog input 2, measured value: 4-20 mA, Ri = 100 Ω, adjustable curve, only usable as alternative to input Ain2U; SELV
KL 3	14	Aout	Analog output 0-10 VDC, max. 5 mA, output of current motor modulation level / motor speed adjustable curve; SELV



# EC axial fan - HyBlade

sickle-shaped blades (S series)

with guard grille for full nozzle

## Curves: Air performance 50 Hz

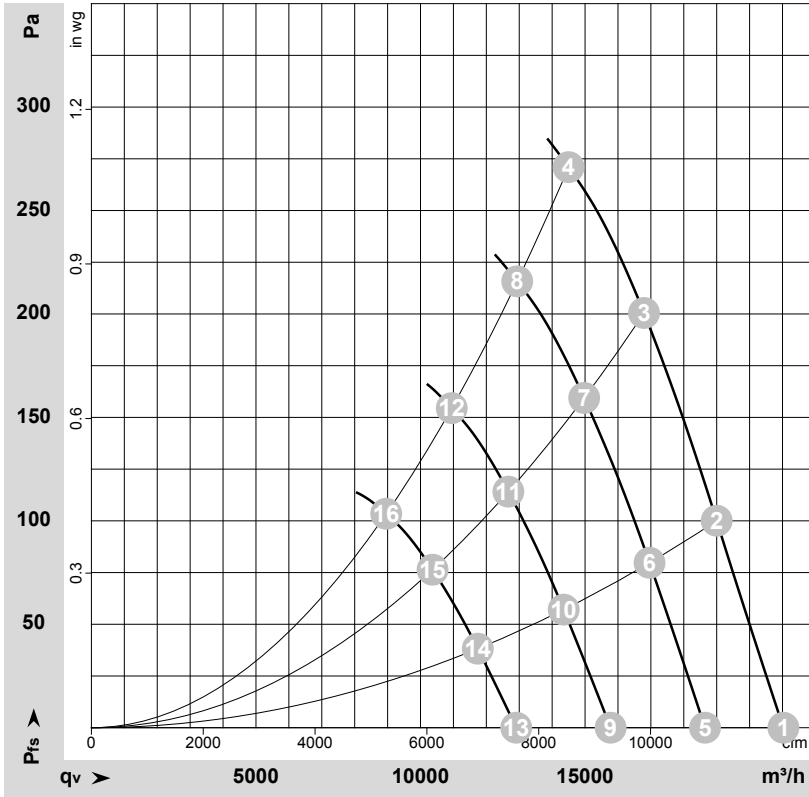

$\rho = 1.173 \text{ kg/m}^3 \pm 2 \%$

Measurement: LU-176534-1

Air performance measured according to ISO 5801 installation category A. For detailed information on the measurement setup, contact ebmpapst. Intake sound level: Sound power level according to ISO 13347 / sound pressure level measured at 1 m distance from fan axis. The values given are valid under the specified measuring conditions and may vary due to conditions of installation. For deviations from the standard configuration, the parameters have to be checked on the installed unit.

## Measured values

	Wired	U	f	n	P <sub>ed</sub>	I	LpA <sub>in</sub>	LwA <sub>in</sub>	LwA <sub>out</sub>	qv	p <sub>fs</sub>	qv	p <sub>fs</sub>
		V	Hz	min <sup>-1</sup>	W	A	dB(A)	dB(A)	dB(A)	m <sup>3</sup> /h	Pa	CFM	inH <sub>2</sub> O
1	Y	200	50	1450	2385	7.26	73	81	82	21025	0	12375	0.00
2	Y	200	50	1450	2556	7.78	73	80	81	19000	100	11185	0.40
3	Y	200	50	1450	2779	8.46	73	80	80	16790	200	9885	0.80
4	Y	200	50	1450	2950	8.90	75	82	81	14500	270	8535	1.08
5	Y	200	50	1300	1663	5.06	70	78	79	18645	0	10975	0.00
6	Y	200	50	1300	1818	5.53	70	77	78	16960	80	9980	0.32
7	Y	200	50	1300	1970	6.00	70	77	77	14975	160	8815	0.64
8	Y	200	50	1300	2082	6.34	72	79	78	12940	216	7615	0.87
9	Y	200	50	1100	1007	3.07	66	74	75	15775	0	9285	0.00
10	Y	200	50	1100	1101	3.35	66	73	74	14350	57	8445	0.23
11	Y	200	50	1100	1193	3.63	66	73	73	12670	114	7455	0.46
12	Y	200	50	1100	1261	3.84	68	75	74	10950	155	6445	0.62
13	Y	200	50	900	552	1.68	61	69	69	12910	0	7600	0.00
14	Y	200	50	900	603	1.84	60	68	69	11740	38	6910	0.15
15	Y	200	50	900	654	1.99	61	68	68	10365	77	6100	0.31
16	Y	200	50	900	691	2.10	63	70	69	8960	104	5270	0.42

Wired = Wiring · U = Power supply · f = Frequency · n = Speed (rpm) · P<sub>ed</sub> = Power consumption · I = Current draw · LpA<sub>in</sub> = Sound pressure level intake side · LwA<sub>in</sub> = Sound power level intake side  
 LwA<sub>out</sub> = Sound power level outlet side · qv = Air flow · p<sub>fs</sub> = Pressure increase

