

EC axial fan - HyBlade

sickle-shaped blades (S series)

with guard grille for full nozzle

S3G630-CR85-09 ebmpapst Datasheet

sales@fansco.com

www.fansco.com

Limited partnership · Headquarters Muldingen

Amtsgericht (court of registration) Stuttgart · HRA 590344

General partner Elektrobau Muldingen GmbH · Headquarters Muldingen

Amtsgericht (court of registration) Stuttgart · HRB 590142

Nominal data

Type	S3G630-CR85-09	
Motor	M3G112-IA	
Phase		3~
Nominal voltage	VAC	400
Nominal voltage range	VAC	380 .. 480
Frequency	Hz	50/60
Method of obtaining data		ml
Speed (rpm)	min ⁻¹	1140
Power consumption	W	970
Current draw	A	1.6
Max. back pressure	Pa	170
Max. back pressure	in. wg	0.68
Min. ambient temperature	°C	-25
Max. ambient temperature	°C	60

ml = Max. load · me = Max. efficiency · fa = Free air · cs = Customer specification · ce = Customer equipment
Subject to change

Data according to Commission Regulation (EU) 327/2011 (EN 17166)

		Actual	Req. 2015			
01 Overall efficiency η_{es}	%	43.8	33.6	09 Power consumption P_{ed}	kW	0.97
02 Measurement category		A		09 Air flow q_v	m ³ /h	8935
03 Efficiency category		Static		09 Pressure increase p_{fs}	Pa	163
04 Efficiency grade N		50.2	40	10 Speed (rpm) n	min ⁻¹	1155
05 Variable speed drive		Yes		11 Specific ratio*		1.00

Data obtained at optimum efficiency level.

* Specific ratio = $1 + p_s / 100\,000\text{ Pa}$

LU-115687

The efficiency values displayed for achieving conformity with the Ecodesign Regulation EU 327/2011 has been reached with defined air duct components (e.g. inlet rings).
The dimensions must be requested from ebm-papst. If other air conduction geometries are used on the installation side, the ebm-papst evaluation loses its validity/the conformity must be confirmed again.
The product does not fall within the scope of Regulation (EU) 2019/1781 due to the exception specified in Article 2 (2a) (motors completely integrated into a product).



EC axial fan - HyBlade

sickle-shaped blades (S series)

with guard grille for full nozzle

Technical description

Weight	15.5 kg
Size	630 mm
Motor size	112
Rotor surface	Painted black
Electronics housing material	Die-cast aluminum, painted black
Blade material	Press-fitted, painted sheet steel blank, sprayed with PP plastic
Guard grille material	Stainless steel
Number of blades	5
Airflow direction	A
Direction of rotation	Clockwise, viewed toward rotor
Degree of protection	IP54
Insulation class	"B"
Moisture (F) / Environmental (H) protection class	H2+
Max. permitted ambient temp. for motor (transport/storage)	+80 °C
Min. permitted ambient temp. for motor (transport/storage)	-40 °C
Installation position	Shaft horizontal or rotor on top; rotor on bottom on request
Condensation drainage holes	On stator side
Mode	S1
Motor bearing	Ball bearing
Technical features	<ul style="list-style-type: none"> - Output 10 VDC, max. 10 mA - Output 20 VDC, max. 50 mA - Output for slave 0-10 V - Input for sensor 0-10 V or 4-20 mA - External 24 V input (parameter setting) - Alarm relay - Integrated PID controller - Motor current limitation - PFC, passive - RS-485 MODBUS-RTU - Soft start - Control input 0-10 VDC / PWM - Control interface with SELV potential safely disconnected from the mains - Thermal overload protection for electronics/motor - Line undervoltage / phase failure detection
Touch current according to IEC 60990 (measuring circuit Fig. 4, TN system)	<= 3.5 mA
Electrical hookup	Terminal box
Motor protection	Thermal overload protector (TOP) internally connected
With cable	Variable
Protection class	I (with customer connection of protective earth)
Conformity with standards	EN 61800-5-1; CE; UKCA
Approval	EAC



EC axial fan - HyBlade

sickle-shaped blades (S series)

with guard grille for full nozzle

Product drawing

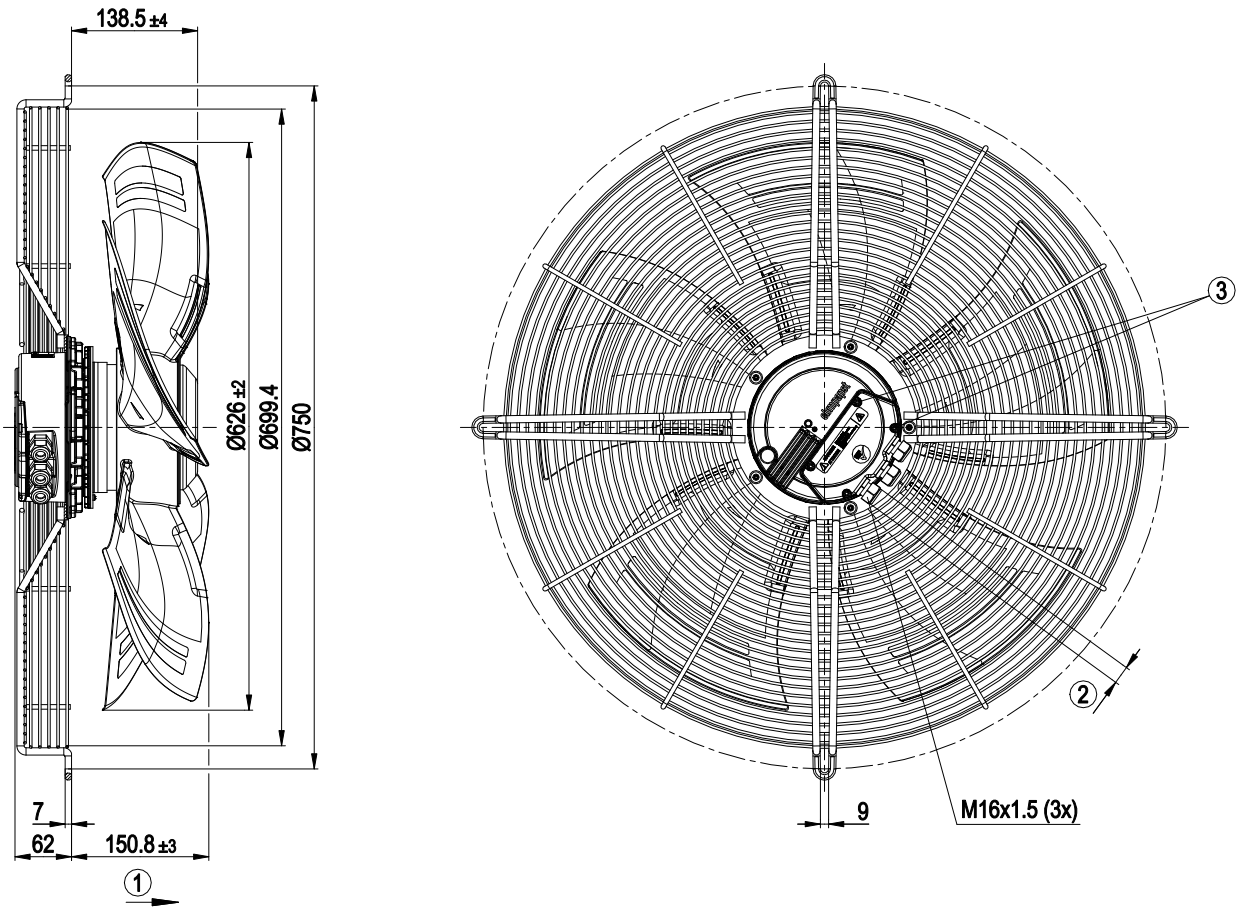

1	Direction of air flow "A"
2	Cable diameter min. 4 mm; max. 10 mm; tightening torque 2 ± 0.3 Nm
3	Tightening torque 3.5 ± 0.5 Nm



EC axial fan - HyBlade

sickle-shaped blades (S series)

with guard grille for full nozzle

Connection diagram

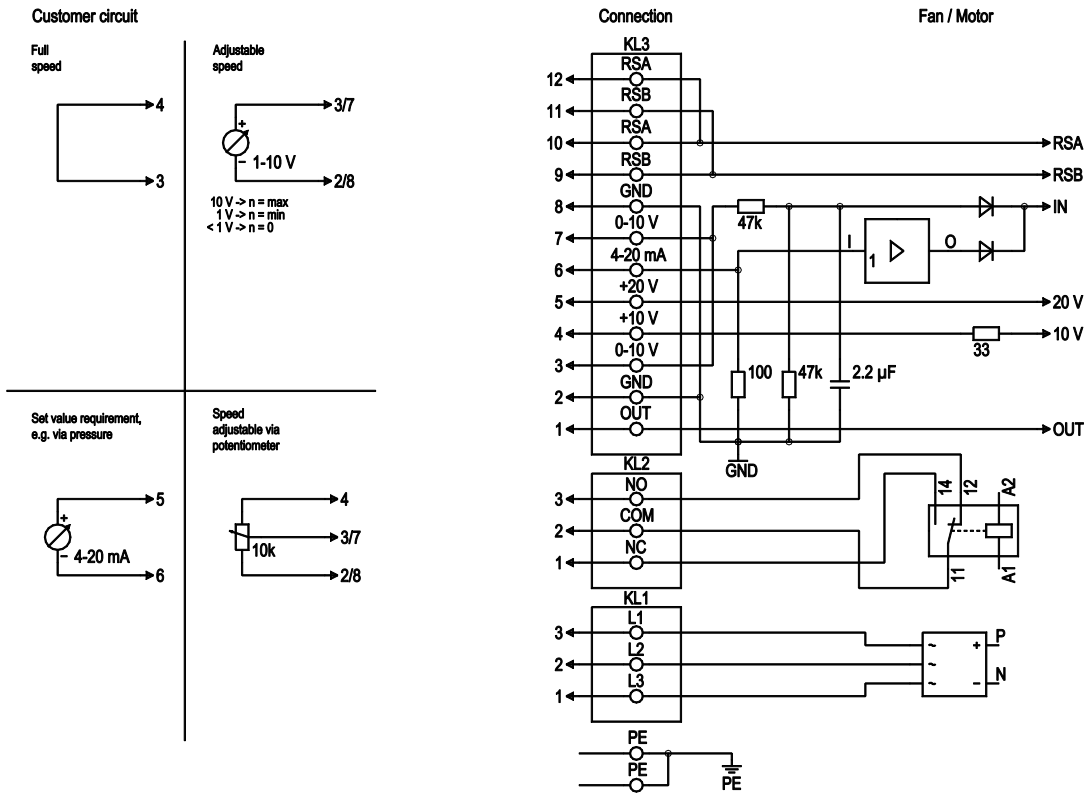

No.	Conn.	Designation	Function/assignment
PE		PE	Protective earth terminal
KL1	1, 2, 3	L1, L2, L3	Power supply, voltage range (see nameplate), 50/60 Hz
KL2	1	NC	Floating status contact, break for failure
KL2	2	COM	floating status contact, changeover contact, common connection (2 A, max. 250 VAC, min. 10 mA, AC1)
KL2	3	NO	Floating status contact, make for failure
KL3	1	OUT	Analog output, 0-10 VDC, max. 3 mA, SELV, output of current motor modulation level: 1 V corresponds to 10% modulation level. 10 V corresponds to 100% modulation level.
KL3	2, 8	GND	Reference ground for control interface, SELV
KL3	3, 7	0-10 V	Use control / current sensor value input 0-10 VDC, impedance 100 kΩ only as alternative to 4-20 mA input, SELV
KL3	4	+10 V	Voltage output 10 VDC (±3%), max. 10 mA, power supply for external devices (e.g. potentiometer), SELV
KL3	5	+20 V	Voltage output 20 VDC (+25%/-10%), max. 50 mA, power supply for external devices (e.g. sensors), SELV
KL3	6	4-20 mA	Use control / current sensor value input 4-20 mA, impedance 100 Ω only as alternative to 0-10 V input, SELV
KL3	9, 11	RSB	RS485 interface for MODBUS, RSB
KL3	10, 12	RSA	RS485 interface for MODBUS, RSA



EC axial fan - HyBlade

sickle-shaped blades (S series)

with guard grille for full nozzle

Curves: Air performance 50 Hz

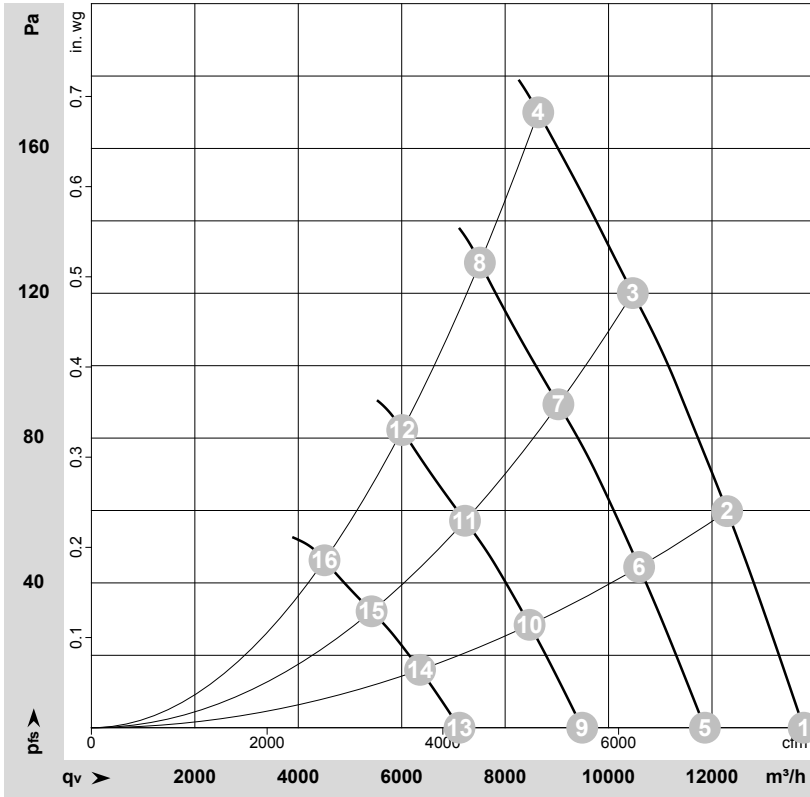

$\rho = 1.15 \text{ kg/m}^3 \pm 2 \%$

Measurement: LU-115687-1

Air performance measured according to ISO 5801 installation category A. For detailed information on the measurement setup, contact ebm-papst. Intake sound level: Sound power level according to ISO 13347 / sound pressure level measured at 1 m distance from fan axis. The values given are valid under the specified measuring conditions and may vary due to conditions of installation. For deviations from the standard configuration, the parameters have to be checked on the installed unit.

Measured values

	Wired	U	f	n	P _{ed}	I	LpA _{in}	LwA _{in}	LwA _{out}	q _v	P _{fs}	q _v	P _{fs}
		V	Hz	min ⁻¹	W	A	dB(A)	dB(A)	dB(A)	m ³ /h	Pa	cfm	in. wg
1	3~	400	50	1140	642	1.02	67	74	74	13775	0	8105	0.00
2	3~	400	50	1140	781	1.26	64	71	71	12295	60	7235	0.24
3	3~	400	50	1140	902	1.44	66	73	72	10470	120	6160	0.48
4	3~	400	50	1140	970	1.60	68	74	74	8640	170	5085	0.68
5	3~	400	50	1000	410	0.65	64	70	70	11865	0	6980	0.00
6	3~	400	50	1000	499	0.80	60	67	67	10590	45	6235	0.18
7	3~	400	50	1000	579	0.92	63	69	68	9030	89	5315	0.36
8	3~	400	50	1000	646	1.04	64	71	70	7510	128	4420	0.51
9	3~	400	50	800	210	0.33	58	65	65	9490	0	5585	0.00
10	3~	400	50	800	255	0.41	55	62	61	8475	29	4985	0.12
11	3~	400	50	800	297	0.47	57	63	62	7225	57	4250	0.23
12	3~	400	50	800	331	0.53	59	65	64	6010	82	3535	0.33
13	3~	400	50	600	89	0.14	51	57	57	7120	0	4190	0.00
14	3~	400	50	600	108	0.17	47	54	54	6355	16	3740	0.06
15	3~	400	50	600	125	0.20	50	56	55	5420	32	3190	0.13
16	3~	400	50	600	140	0.22	52	58	57	4505	46	2655	0.18

Wired = Wiring · U = Voltage · f = Frequency · n = Speed (rpm) · P_{ed} = Power consumption · I = Current draw · LpA_{in} = Sound pressure level intake side · LwA_{in} = Sound power level intake side
 LwA_{out} = Sound power level outlet side · q_v = Air flow · P_{fs} = Pressure increase

