

S3G630-CR85-02 ebmpapst Datasheet

sales@fansco.com

www.fansco.com

Limited partnership · Headquarters Muldingen

Amtsgericht (court of registration) Stuttgart · HRA 590344

General partner Elektrobau Muldingen GmbH · Headquarters Muldingen

Amtsgericht (court of registration) Stuttgart · HRB 590142



Nominal data

Type	S3G630-CR85-02	
Motor	M3G112-IA	
Phase		3~
Nominal voltage	VAC	400
Nominal voltage range	VAC	380 .. 480
Frequency	Hz	50/60
Method of obtaining data		ml
Speed (rpm)	min ⁻¹	1140
Power consumption	W	970
Current draw	A	1.6
Max. back pressure	Pa	170
Max. back pressure	inH ₂ O	0.68
Min. ambient temperature	°C	-25
Max. ambient temperature	°C	60

ml = Max. load · me = Max. efficiency · fa = Free air · cs = Customer specification · ce = Customer equipment
Subject to change

Data according to ErP Directive

		Actual	Req. 2015			
01 Overall efficiency η_{es}	%	45.1	33.6	09 Power consumption P_{ed}	kW	0.97
02 Measurement category		A		09 Air flow q_v	m ³ /h	8935
03 Efficiency category		Static		09 Pressure increase p_{fs}	Pa	163
04 Efficiency grade N		51.5	40	10 Speed (rpm) n	min ⁻¹	1155
05 Variable speed drive		Yes		11 Specific ratio*		1.00

Data obtained at optimum efficiency level.

The ErP data is determined using a motor-impeller combination in a standardized measurement setup.

* Specific ratio = $1 + p_s / 100\,000\text{ Pa}$

LU-115687



Technical description

Weight	15.4 kg
Fan size	630 mm
Rotor surface	Painted black
Electronics housing material	Die-cast aluminum, painted black
Blade material	Press-fitted sheet steel blank, sprayed with PP plastic
Guard grille material	Steel, coated with black plastic (RAL 9005)
Number of blades	5
Airflow direction	"A"
Direction of rotation	Clockwise, viewed toward rotor
Degree of protection	IP54
Insulation class	"B"
Moisture (F) / Environmental (H) protection class	F4-1
Max. permitted ambient temp. for motor (transport/storage)	+80 °C
Min. permitted ambient temp. for motor (transport/storage)	-40 °C
Installation position	Shaft horizontal or rotor on bottom; rotor on top on request
Condensation drainage holes	On rotor side
Mode	S1
Motor bearing	Ball bearing
Technical features	<ul style="list-style-type: none"> - Output 10 VDC, max. 10 mA - Alarm relay - Integrated PID controller - Motor current limitation - PFC, passive - Soft start - Control input 0-10 VDC / PWM - Control interface with SELV potential safely disconnected from the mains - Thermal overload protection for electronics/motor - Line undervoltage / phase failure detection
EMC immunity to interference	According to EN 61000-6-2 (industrial environment)
EMC circuit feedback	According to EN 61000-3-2/3
EMC interference emission	According to EN 61000-6-4 (industrial environment)
Touch current according to IEC 60990 (measuring circuit Fig. 4, TN system)	<= 3.5 mA
Motor protection	Thermal overload protector (TOP) internally connected
With cable	Variable
Protection class	I (with customer connection of protective earth)
Conformity with standards	CE
Approval	EAC

EC axial fan

sickle-shaped blades (S series)
with guard grille for full nozzle

Product drawing

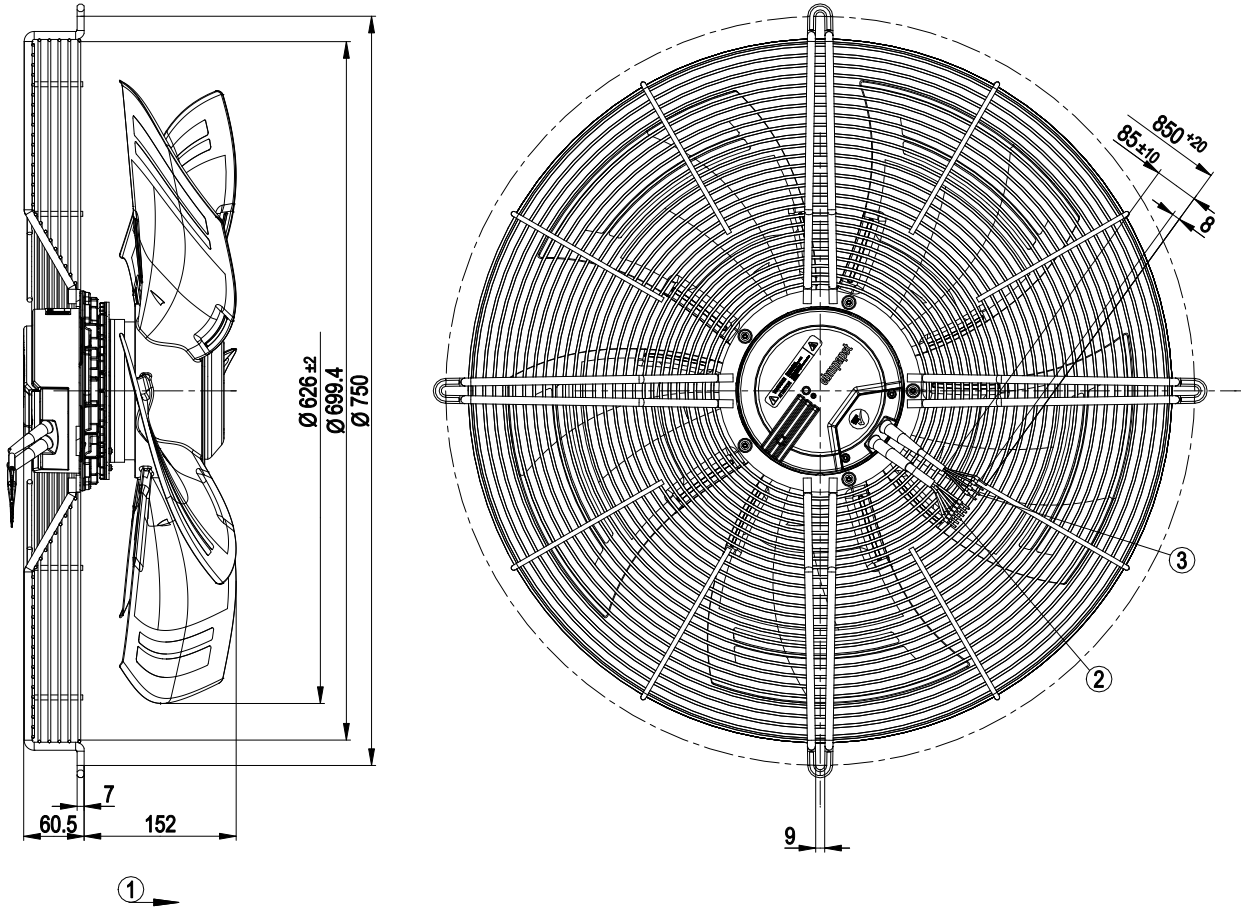

1	Direction of air flow "A"
2	Cable PVC AWG18, 6 x crimped ferrules
3	Cable PVC AWG22, 3 x crimped ferrules



EC axial fan

sickle-shaped blades (S series)
with guard grille for full nozzle

Connection diagram

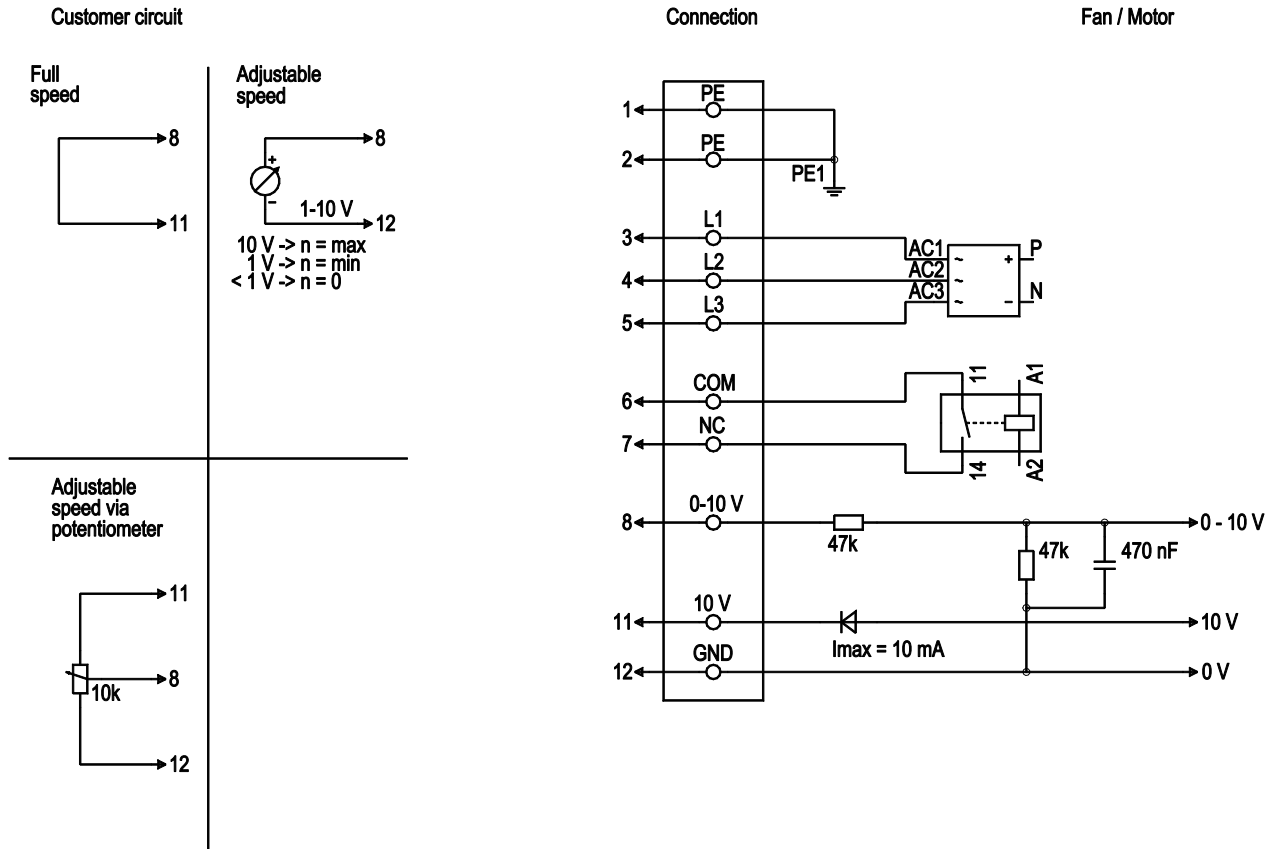

No.	Conn.	Designation	Color	Function/assignment
1	1, 2	PE	green/yellow	Protective earth
1	3, 4, 5	L1, L2, L3	black	Power supply 50 / 60 Hz
1	6	COM	white 1	Floating status contact, break for failure (2A, max. 250 VAC, min. 10 mA, AC1)
1	7	NC	white 2	Floating status contact, break for failure
2	8	0 - 10 V	yellow	Control input, set value 0-10 VDC, impedance 100 kOhm, SELV
2	11	+ 10 V	red	Voltage output 10 VDC ($\pm 3\%$), max. 10 mA, power supply for external devices (e.g. potentiometers), SELV
2	12	GND	blue	Reference ground for control interface, SELV



EC axial fan

sickle-shaped blades (S series)
with guard grille for full nozzle

Curves: Air performance 50 Hz

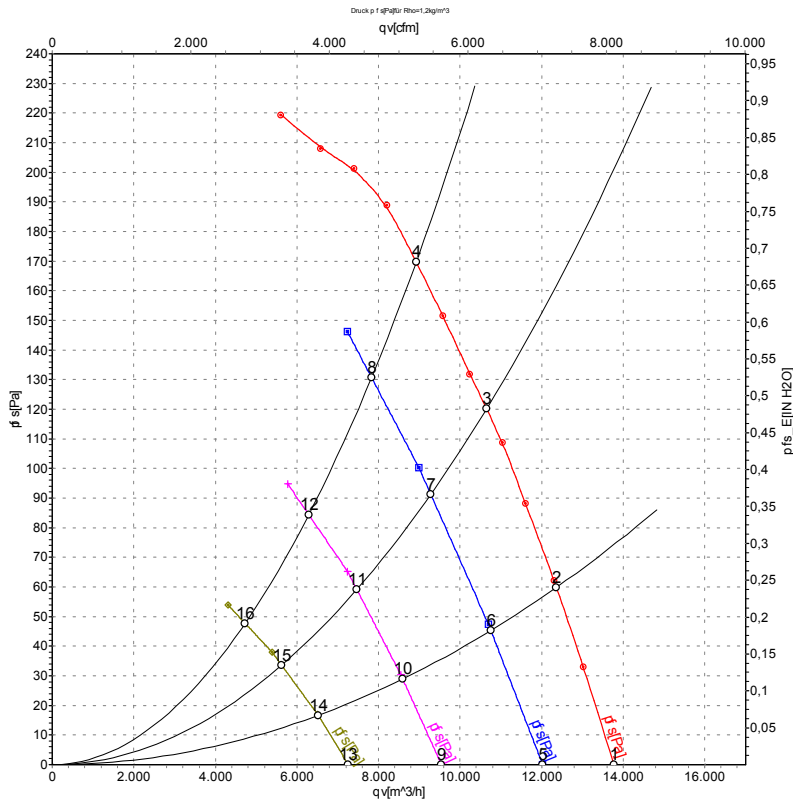

Measurement: LU-115687-1
Measurement: LU-118125-1
Measurement: LU-118126-1
Measurement: LU-118127-1

Air performance measured according to ISO 5801 installation category A. For detailed information on the measurement setup, contact ebm-papst. Intake sound level: Sound power level according to ISO 13347 / sound pressure level measured at 1 m distance from fan axis. The values given are valid under the specified measuring conditions and may vary due to conditions of installation. For deviations from the standard configuration, the parameters have to be checked on the installed unit.

Measured values

	U	f	n	P _{ed}	I	LpA _{in}	LwA _{in}	LwA _{out}	qv	P _{fs}	qv	P _{fs}
	V	Hz	min ⁻¹	W	A	dB(A)	dB(A)	dB(A)	m ³ /h	Pa	CFM	inH ₂ O
1	400	50	1140	642	1.02	67	74	74	13770	0	8105	0.00
2	400	50	1140	775	1.25	64	71	71	12360	60	7275	0.24
3	400	50	1140	892	1.42	66	72	71	10650	120	6270	0.48
4	400	50	1140	970	1.60	68	74	73	8920	170	5250	0.68
5	400	50	1000	406	0.75	64	71	70	12020	0	7075	0.00
6	400	50	1000	490	0.86	61	68	67	10750	45	6325	0.18
7	400	50	1000	564	0.95	62	69	68	9280	91	5460	0.37
8	400	50	1000	626	1.05	63	70	69	7830	131	4610	0.53
9	400	50	800	224	0.45	59	65	65	9540	0	5615	0.00
10	400	50	800	270	0.53	56	62	62	8595	29	5060	0.12
11	400	50	800	300	0.58	56	63	62	7470	59	4395	0.24
12	400	50	800	331	0.64	57	64	64	6290	84	3700	0.34
13	400	50	600	109	0.25	52	59	58	7255	0	4270	0.00
14	400	50	600	124	0.28	50	56	56	6520	17	3840	0.07
15	400	50	600	139	0.31	50	56	56	5625	34	3310	0.14
16	400	50	600	152	0.33	50	57	57	4730	48	2785	0.19

U = Power supply · f = Frequency · n = Speed (rpm) · P_{ed} = Power consumption · I = Current draw · LpA_{in} = Sound pressure level intake side · LwA_{in} = Sound power level intake side
LwA_{out} = Sound power level outlet side · qv = Air flow · p_{fs} = Pressure increase

