

S3G630-AQ37-21 ebmpapst Datasheet

sales@fansco.com

www.fansco.com

Limited partnership · Headquarters Mulfingen

Amtsgericht (court of registration) Stuttgart · HRA 590344

General partner Elektrobau Mulfingen GmbH · Headquarters Mulfingen

Amtsgericht (court of registration) Stuttgart · HRB 590142



## Nominal data

Type	S3G630-AQ37-21	
Motor	M3G112-GA	
Phase		1~
Nominal voltage	VAC	230
Nominal voltage range	VAC	200 .. 277
Frequency	Hz	50/60
Method of obtaining data		ml
Speed (rpm)	min <sup>-1</sup>	1000
Power consumption	W	720
Current draw	A	3.2
Max. back pressure	Pa	140
Max. back pressure	inH <sub>2</sub> O	0.56
Min. ambient temperature	°C	-25
Max. ambient temperature	°C	60

ml = Max. load · me = Max. efficiency · fa = Free air · cs = Customer specification · ce = Customer equipment  
Subject to change

## Data according to ErP Directive

		Actual	Req. 2015		
01 Overall efficiency $\eta_{es}$	%	44.1	32.7	09 Power consumption $P_{ed}$	kW
02 Measurement category		A		09 Air flow $q_v$	m <sup>3</sup> /h
03 Efficiency category		Static		09 Pressure increase $p_{fs}$	Pa
04 Efficiency grade N		51.4	40	10 Speed (rpm) n	min <sup>-1</sup>
05 Variable speed drive		Yes		11 Specific ratio*	

Data obtained at optimum efficiency level.

The ErP data is determined using a motor-impeller combination in a standardized measurement setup.

\* Specific ratio =  $1 + p_s / 100\,000\text{ Pa}$ 

LU-116825



### Technical description

Weight	15.3 kg
Fan size	630 mm
Rotor surface	Painted black
Blade material	Press-fitted sheet steel blank, sprayed with PP plastic
Guard grille material	Steel, coated with black plastic (RAL 9005)
Number of blades	5
Airflow direction	"V"
Direction of rotation	Counterclockwise, viewed toward rotor
Degree of protection	IP54
Insulation class	"B"
Moisture (F) / Environmental (H) protection class	F4-1
Max. permitted ambient temp. for motor (transport/storage)	+80 °C
Min. permitted ambient temp. for motor (transport/storage)	-40 °C
Installation position	Shaft horizontal or rotor on bottom; rotor on top on request
Condensation drainage holes	On rotor side
Mode	S1
Motor bearing	Ball bearing
Technical features	<ul style="list-style-type: none"> <li>- Output 10 VDC, max. 10 mA</li> <li>- Alarm relay</li> <li>- Motor current limitation</li> <li>- PFC, active</li> <li>- Soft start</li> <li>- Control input 0-10 VDC</li> <li>- Control interface with SELV potential safely disconnected from supply</li> <li>- Thermal overload protection for electronics/motor</li> <li>- Line undervoltage / phase failure detection</li> </ul>
EMC immunity to interference	According to EN 61000-6-2 (industrial environment)
EMC circuit feedback	According to EN 61000-3-2/3
EMC interference emission	According to EN 61000-6-4 (industrial environment)
Touch current according to IEC 60990 (measuring circuit Fig. 4, TN system)	<= 3.5 mA
Motor protection	Thermal overload protector (TOP) internally connected
With cable	Variable
Protection class	I (with customer connection of protective earth)
Conformity with standards	EN 61800-5-1; CE
Approval	CCC; EAC

# EC axial fan - HyBlade

sickle-shaped blades (S series)  
with guard grille for short nozzle

## Product drawing

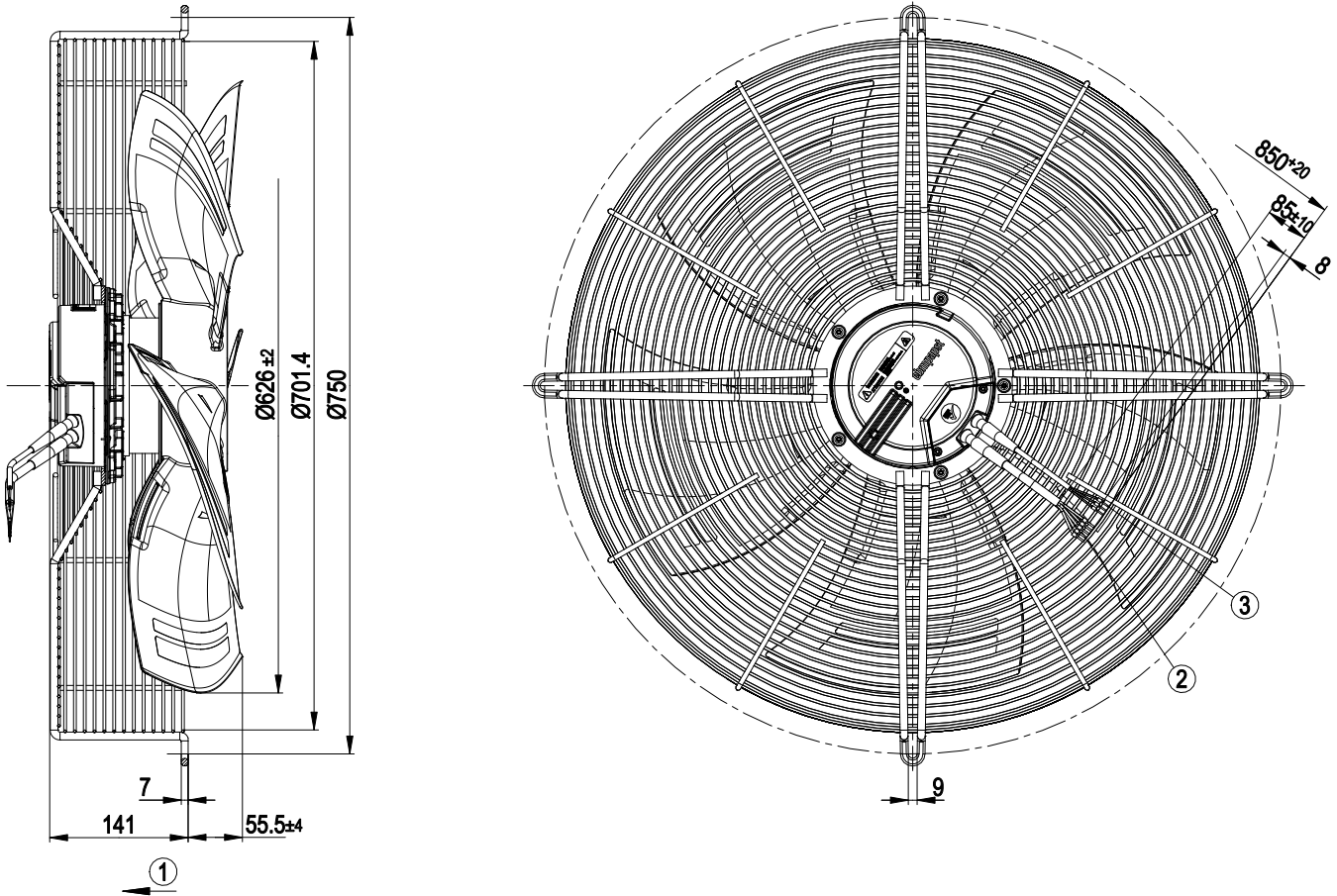

1	Direction of air flow "V"
2	Cable PVC AWG18, 5x crimped ferrules
3	Cable PVC AWG22, 3x crimped ferrules



# EC axial fan - HyBlade

sickle-shaped blades (S series)  
with guard grille for short nozzle

## Connection diagram

### Customer circuit

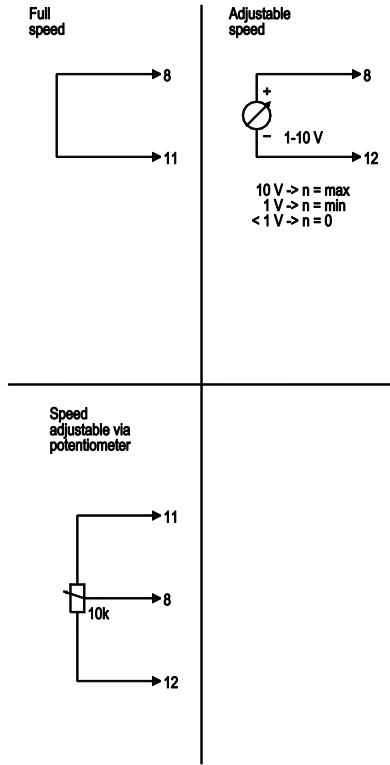

### Connection

### Fan / Motor

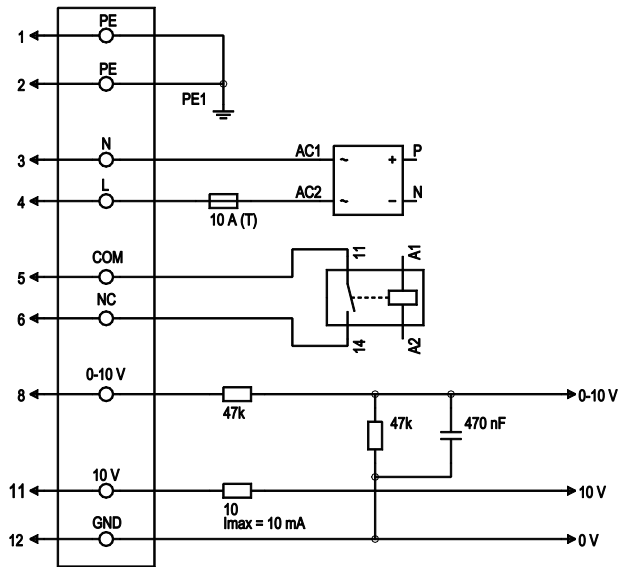

No.	Conn.	Designation	Color	Function/assignment
1	1,2	PE	green/yellow	Protective earth
1	3	N	blue	Power supply, neutral conductor, 50/60 Hz
1	4	L	black	Power supply, phase, 50/60 Hz
1	5	COM	white 1	Floating status contact, break for failure (2 A, max. 250 VAC, min. 10 mA, AC1)
1	6	NC	white 2	Floating status contact, break for failure
2	8	0-10 V	yellow	Control input, set value 0-10 VDC, impedance 100 kΩ, SELV
2	11	10 VDC	red	Voltage output 10 VDC (±3%), max. 10 mA, power supply for external devices (e.g. potentiometer), SELV
2	12	GND	blue	Reference ground for control interface, SELV



## Curves: Air performance 50 Hz

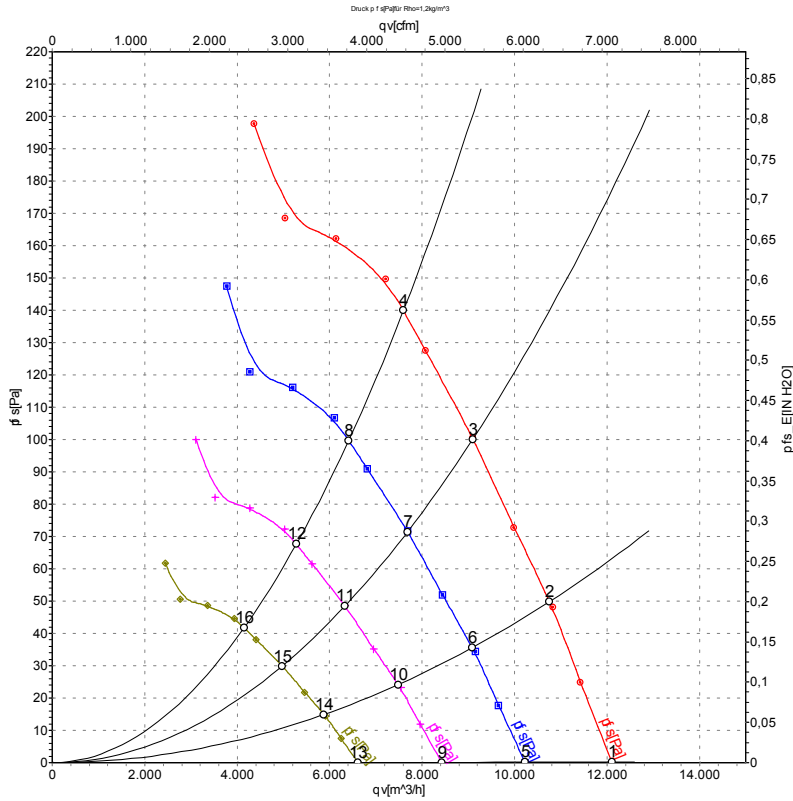

Measurement: LU-116825-1

Air performance measured according to ISO 5801 installation category A. For detailed information on the measurement setup, contact ebm-papst. Intake sound level: Sound power level according to ISO 13347 / sound pressure level measured at 1 m distance from fan axis. The values given are valid under the specified measuring conditions and may vary due to conditions of installation. For deviations from the standard configuration, the parameters have to be checked on the installed unit.

## Measured values

	U	f	n	P <sub>ed</sub>	I	LpA <sub>in</sub>	LwA <sub>in</sub>	LwA <sub>out</sub>	qv	P <sub>fs</sub>	qv	P <sub>fs</sub>
	V	Hz	min <sup>-1</sup>	W	A	dB(A)	dB(A)	dB(A)	m <sup>3</sup> /h	Pa	CFM	inH2O
1	230	50	1000	462	2.11	65	71	71	12100	0	7120	0.00
2	230	50	1000	559	2.54	61	68	67	10750	50	6325	0.20
3	230	50	1000	653	2.94	62	69	68	9100	100	5355	0.40
4	230	50	1000	720	3.20	64	71	70	7595	140	4470	0.56
5	230	50	850	279	1.27	61	67	67	10230	0	6020	0.00
6	230	50	850	337	1.53	58	64	64	9085	36	5345	0.14
7	230	50	850	394	1.77	59	65	64	7685	72	4525	0.29
8	230	50	850	429	1.93	61	67	67	6415	100	3775	0.40
9	230	50	700	156	0.71	57	63	63	8420	0	4955	0.00
10	230	50	700	188	0.86	53	60	60	7480	24	4405	0.10
11	230	50	700	220	0.99	55	61	60	6330	49	3725	0.20
12	230	50	700	240	1.08	57	63	63	5280	68	3110	0.27
13	230	50	550	76	0.35	52	58	58	6615	0	3895	0.00
14	230	50	550	91	0.42	48	55	54	5880	15	3460	0.06
15	230	50	550	107	0.48	49	56	55	4975	30	2925	0.12
16	230	50	550	116	0.52	51	58	57	4150	42	2445	0.17

U = Power supply · f = Frequency · n = Speed (rpm) · P<sub>ed</sub> = Power consumption · I = Current draw · LpA<sub>in</sub> = Sound pressure level intake side · LwA<sub>in</sub> = Sound power level intake side  
LwA<sub>out</sub> = Sound power level outlet side · qv = Air flow · P<sub>fs</sub> = Pressure increase

