

S3G630-AE55-21 ebmpapst Datasheet

sales@fansco.com

www.fansco.com

## Nominal data

Type	S3G630-AE55-21	
Motor	M3G112-GA	
Phase		1~
Nominal voltage	VAC	230
Nominal voltage range	VAC	200 .. 277
Frequency	Hz	50/60
Method of obtaining data		ml
Speed (rpm)	min <sup>-1</sup>	1020
Power consumption	W	730
Current draw	A	3.2
Max. back pressure	Pa	150
Max. back pressure	in. wg	0.6
Min. ambient temperature	°C	-25
Max. ambient temperature	°C	60

ml = Max. load · me = Max. efficiency · fa = Free air · cs = Customer specification · ce = Customer equipment  
Subject to change

## Data according to Commission Regulation (EU) 327/2011 (EN 17166)

		Actual	Req. 2015			
01 Overall efficiency $\eta_{es}$	%	44.4	32.6	09 Power consumption $P_{ed}$	kW	0.68
02 Measurement category		A		09 Air flow $q_v$	m <sup>3</sup> /h	8225
03 Efficiency category		Static		09 Pressure increase $p_{fs}$	Pa	122
04 Efficiency grade N		51.8	40	10 Speed (rpm) n	min <sup>-1</sup>	1020
05 Variable speed drive		Yes		11 Specific ratio*		1.00

Data obtained at optimum efficiency level.

\* Specific ratio =  $1 + p_s / 100\,000\text{ Pa}$ 

LU-165392

The efficiency values displayed for achieving conformity with the Ecodesign Regulation EU 327/2011 has been reached with defined air duct components (e.g. inlet rings).  
The dimensions must be requested from ebm-papst. If other air conduction geometries are used on the installation side, the ebm-papst evaluation loses its validity/the conformity must be confirmed again.  
The product does not fall within the scope of Regulation (EU) 2019/1781 due to the exception specified in Article 2 (2a) (motors completely integrated into a product).



# EC axial fan - HyBlade

sickle-shaped blades (S series)

with guard grille for short nozzle

## Technical description

<b>Weight</b>	15.2 kg
<b>Size</b>	630 mm
<b>Motor size</b>	112
<b>Rotor surface</b>	Painted black
<b>Terminal box material</b>	PP plastic
<b>Electronics housing material</b>	Die-cast aluminum, painted black
<b>Blade material</b>	Press-fitted sheet steel blank, sprayed with PP plastic
<b>Guard grille material</b>	Steel, coated with black plastic (RAL 9005)
<b>Number of blades</b>	5
<b>Airflow direction</b>	V
<b>Direction of rotation</b>	Counterclockwise, viewed toward rotor
<b>Degree of protection</b>	IP55
<b>Insulation class</b>	"F"
<b>Moisture (F) / Environmental (H) protection class</b>	H2
<b>Ambient temperature note</b>	Occasional start-up between -40°C and -25°C is permissible. For continuous operation at temperatures below -25°C (e.g. refrigeration applications) we recommend our fan design with special low-temperature bearings.
<b>Max. permitted ambient temp. for motor (transport/storage)</b>	+80 °C
<b>Min. permitted ambient temp. for motor (transport/storage)</b>	-40 °C
<b>Installation position</b>	Shaft horizontal or rotor on bottom; rotor on top on request
<b>Condensation drainage holes</b>	On rotor side
<b>Mode</b>	S1
<b>Motor bearing</b>	Ball bearing; (sealed)
<b>Technical features</b>	<ul style="list-style-type: none"> <li>- Output 10 VDC, max. 10 mA</li> <li>- Operation and alarm display</li> <li>- Alarm relay</li> <li>- Integrated PID controller</li> <li>- Power limiter</li> <li>- Motor current limitation</li> <li>- PFC, active</li> <li>- RS-485 MODBUS-RTU</li> <li>- Soft start</li> <li>- Control input 0-10 VDC / PWM</li> <li>- Control interface with SELV potential safely disconnected from supply</li> <li>- Thermal overload protection for electronics/motor</li> <li>- Line undervoltage / phase failure detection</li> </ul>
<b>EMC immunity to interference</b>	According to EN 61000-6-2 (industrial environment)
<b>EMC circuit feedback</b>	According to EN 61000-3-2/3
<b>EMC interference emission</b>	According to EN 61000-6-3 (household environment)
<b>Touch current according to IEC 60990 (measuring circuit Fig. 4, TN system)</b>	<= 3.5 mA
<b>Electrical hookup</b>	Terminal box
<b>Motor protection</b>	Thermal overload protector (TOP) internally connected
<b>Protection class</b>	I (with customer connection of protective earth)
<b>Conformity with standards</b>	EN 61800-5-1; UKCA; CE



S3G630-AE55-21

## EC axial fan - HyBlade

sickle-shaped blades (S series)  
with guard grille for short nozzle

<b>Approval</b>	CSA C22.2 No. 77 + CAN/CSA-E60730-1; CCC; EAC; UL 1004-7 + 60730-1
<b>Comment</b>	Conformity with EN 60335-1 in preparation



# EC axial fan - HyBlade

sickle-shaped blades (S series)  
with guard grille for short nozzle

## Product drawing

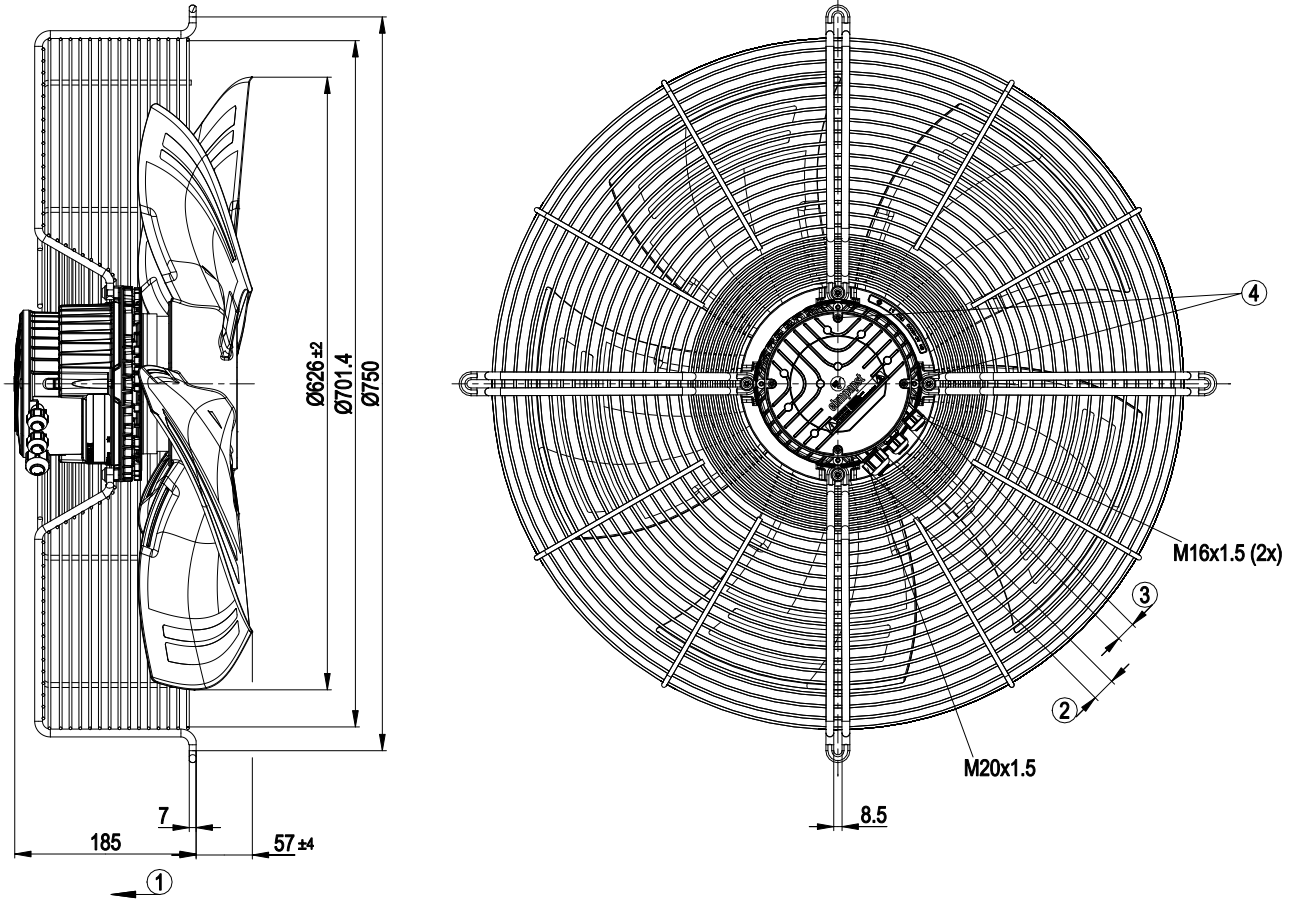

1	Direction of air flow "V"
2	Cable diameter min. 8 mm, max. 12 mm, tightening torque 1.8±0.3 Nm (use must be made of seal provided) Cable diameter min. 4 mm, max. 10 mm, tightening torque 1.8±0.3 Nm
3	Cable diameter min. 6 mm, max. 10 mm, tightening torque 1.8±0.3 Nm (use must be made of seal provided) Cable diameter min. 4 mm, max. 7 mm, tightening torque 1.8±0.3 Nm
4	Tightening torque 1.5 ± 0.2 Nm



# EC axial fan - HyBlade

sickle-shaped blades (S series)

with guard grille for short nozzle

## Connection diagram

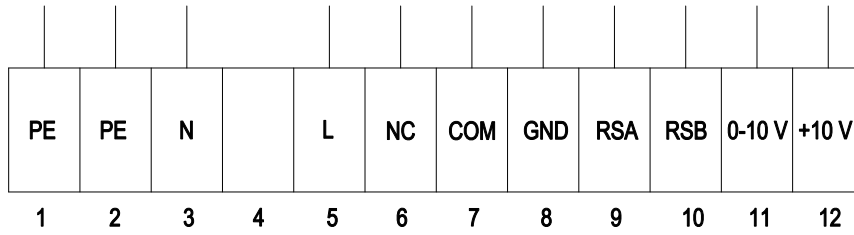

No.	Conn.	Designation	Function/assignment
1	PE	PE	Protective earth
2	PE	PE	Protective earth
3	N	N	Power supply, neutral conductor
4	-	-	not used
5	L	L	Power supply, phase
6	NC	NC	Status relay, floating status contact, break for failure, contact rating 250 VAC / 2 A (AC1) / min. 10 mA; basic insulation on supply side and reinforced insulation on control interface side
7	COM	COM	Status relay, floating status contact, common connection, contact rating 250 VAC / 2 A (AC1) / min. 10 mA; basic insulation on supply side and reinforced insulation on control interface side
8	GND	GND	Reference ground for control interface, SELV
9	RSA	RSA	RS485 interface for MODBUS, RSA; SELV
10	RSB	RSB	RS485 interface for MODBUS, RSB; SELV
11	0-10 V	0-10 V	Analog input (set value) SELV, 0-10 V, Ri = 100 kΩ, adjustable curve
12	+10 V	+10 V	Fixed voltage output 10 VDC, SELV, +10 V ±3%, max. 10 mA, short-circuit-proof, power supply for external devices (e.g. pot)



## Curves: Air performance 50 Hz

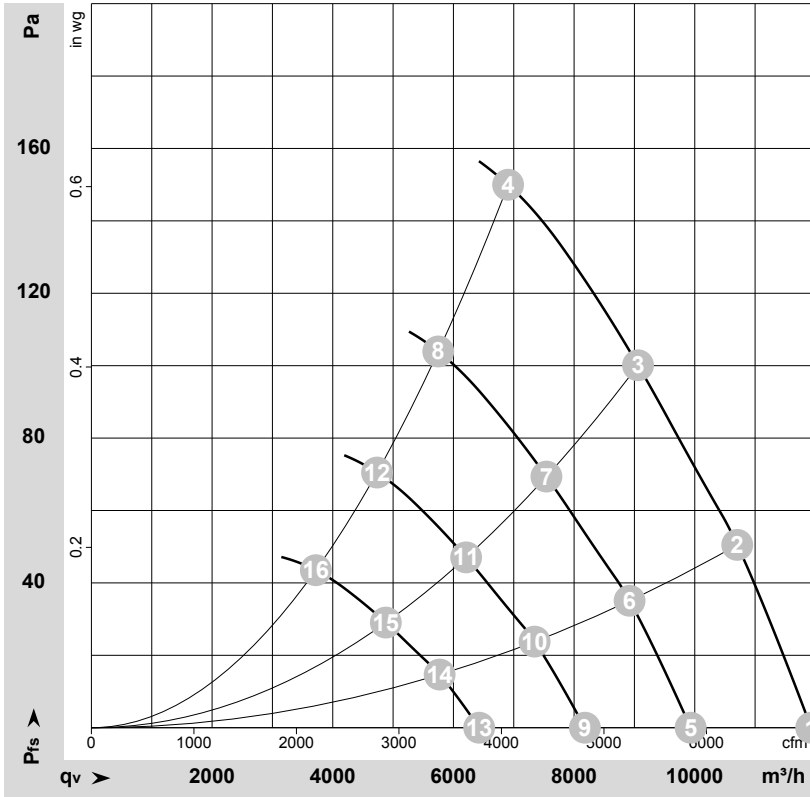

$\rho = 1.15 \text{ kg/m}^3 \pm 2 \%$

Measurement: LU-157258-1

Air performance measured according to ISO 5801 installation category A. For detailed information on the measurement setup, contact ebmpapst. Intake sound level: Sound power level according to ISO 13347 / sound pressure level measured at 1 m distance from fan axis. The values given are valid under the specified measuring conditions and may vary due to conditions of installation. For deviations from the standard configuration, the parameters have to be checked on the installed unit.

## Measured values

	U	f	n	P <sub>ed</sub>	I	LpA <sub>in</sub>	LwA <sub>in</sub>	LwA <sub>out</sub>	q <sub>v</sub>	P <sub>fs</sub>	q <sub>v</sub>	P <sub>fs</sub>
	V	Hz	min <sup>-1</sup>	W	A	dB(A)	dB(A)	dB(A)	m <sup>3</sup> /h	Pa	cfm	in. wg
1	230	50	1020	463	2.08	69	76	75	11930	0	7020	0.00
2	230	50	1020	555	2.47	65	72	71	10705	50	6300	0.20
3	230	50	1020	648	2.86	63	70	69	9060	100	5335	0.40
4	230	50	1020	730	3.20	66	73	73	6905	150	4065	0.60
5	230	50	850	267	1.20	64	71	71	9930	0	5845	0.00
6	230	50	850	321	1.43	60	67	66	8920	36	5250	0.14
7	230	50	850	374	1.65	58	65	64	7540	70	4440	0.28
8	230	50	850	421	1.85	61	69	69	5750	104	3385	0.42
9	230	50	700	149	0.67	59	66	66	8180	0	4815	0.00
10	230	50	700	179	0.80	55	62	62	7345	24	4325	0.10
11	230	50	700	209	0.92	53	60	60	6210	47	3655	0.19
12	230	50	700	235	1.03	57	64	64	4735	70	2785	0.28
13	230	50	550	72	0.33	53	60	60	6425	0	3780	0.00
14	230	50	550	87	0.39	49	56	56	5770	15	3395	0.06
15	230	50	550	101	0.45	47	54	54	4880	29	2870	0.12
16	230	50	550	114	0.50	50	58	58	3720	44	2190	0.18

U = Voltage · f = Frequency · n = Speed (rpm) · P<sub>ed</sub> = Power consumption · I = Current draw · LpA<sub>in</sub> = Sound pressure level intake side · LwA<sub>in</sub> = Sound power level intake side  
LwA<sub>out</sub> = Sound power level outlet side · q<sub>v</sub> = Air flow · P<sub>fs</sub> = Pressure increase

