

EC axial fan - HyBlade

sickle-shaped blades (S series)
with support ring, for barn ventilation

S3G560-DP68-35 ebmpapst Datasheet
sales@fansco.com
www.fansco.com

Limited partnership · Headquarters Mulfingen
Amtsgericht (court of registration) Stuttgart · HRA 590344
General partner Elektrobau Mulfingen GmbH · Headquarters Mulfingen
Amtsgericht (court of registration) Stuttgart · HRB 590142

Nominal data

Type	S3G560-DP68-35	
Motor	M3G112-EA	
Phase		1~
Nominal voltage	VAC	230
Nominal voltage range	VAC	200 .. 277
Frequency	Hz	50/60
Method of obtaining data		ml
Speed (rpm)	min ⁻¹	1000
Power consumption	W	400
Current draw	A	1.8
Max. back pressure	Pa	100
Max. back pressure	in. wg	0.4
Min. ambient temperature	°C	-25
Max. ambient temperature	°C	60

ml = Max. load · me = Max. efficiency · fa = Free air · cs = Customer specification · ce = Customer equipment
Subject to change

Data according to Commission Regulation (EU) 327/2011

		Actual	Req. 2015			
01 Overall efficiency η_{es}	%	40.4	31.2	09 Power consumption P_{ed}	kW	0.4
02 Measurement category		A		09 Air flow q_v	m ³ /h	5250
03 Efficiency category		Static		09 Pressure increase p_{fs}	Pa	107
04 Efficiency grade N		49.2	40	10 Speed (rpm) n	min ⁻¹	1005
05 Variable speed drive		Yes		11 Specific ratio*		1.00

Data obtained at optimum efficiency level.
The ErP data is determined using a motor-impeller combination in a standardized measurement setup.

* Specific ratio = $1 + p_s / 100\,000\text{ Pa}$

LU-201367



EC axial fan - HyBlade

sickle-shaped blades (S series)
with support ring, for barn ventilation

Technical description

Weight	11.6 kg
Size	560 mm
Motor size	112
Rotor surface	Painted black
Electronics housing material	Die-cast aluminum, painted black
Blade material	Press-fitted, painted sheet steel blank, sprayed with PP plastic
Support ring material	Steel, coated with black plastic (RAL 9005)
Number of blades	5
Blade pitch	-5°
Airflow direction	A
Direction of rotation	Clockwise, viewed toward rotor
Degree of protection	IP54
Insulation class	"B"
Moisture (F) / Environmental (H) protection class	H2+A
Ambient temperature note	Occasional start-up at temperatures between -40°C and -25°C is permitted. For continuous operation at ambient temperatures below -25°C (such as refrigeration applications), use must be made of a fan design with special low-temperature bearings.
Max. permitted ambient temp. for motor (transport/storage)	+80 °C
Min. permitted ambient temp. for motor (transport/storage)	-40 °C
Installation position	Shaft horizontal or rotor on top; rotor on bottom on request
Condensation drainage holes	On stator side
Mode	S1
Motor bearing	Ball bearing
Technical features	<ul style="list-style-type: none"> - Output 10 VDC, max. 10 mA - Output 20 VDC, max. 50 mA - Output for slave 0-10 V - Operation and alarm display - Selection of direction of rotation left/right - Input for sensor 0-10 V or 4-20 mA - External 24 V input (parameter setting) - Alarm relay - Integrated PID controller - Power limiter - Motor current limitation - PFC, active - RS-485 MODBUS-RTU - Soft start - Control input 0-10 VDC / PWM - Control interface with SELV potential safely disconnected from the mains - Thermal overload protection for electronics/motor - Line undervoltage / phase failure detection
Touch current according to IEC 60990 (measuring circuit Fig. 4, TN system)	<= 3.5 mA
Electrical hookup	Terminal box
Motor protection	Thermal overload protector (TOP) internally connected
Protection class	I (with customer connection of protective earth)



S3G560-DP68-35

EC axial fan - HyBlade

sickle-shaped blades (S series)

with support ring, for barn ventilation

Conformity with standards	EN 61800-5-1; CE
Approval	EAC



EC axial fan - HyBlade

sickle-shaped blades (S series)
with support ring, for barn ventilation

Product drawing

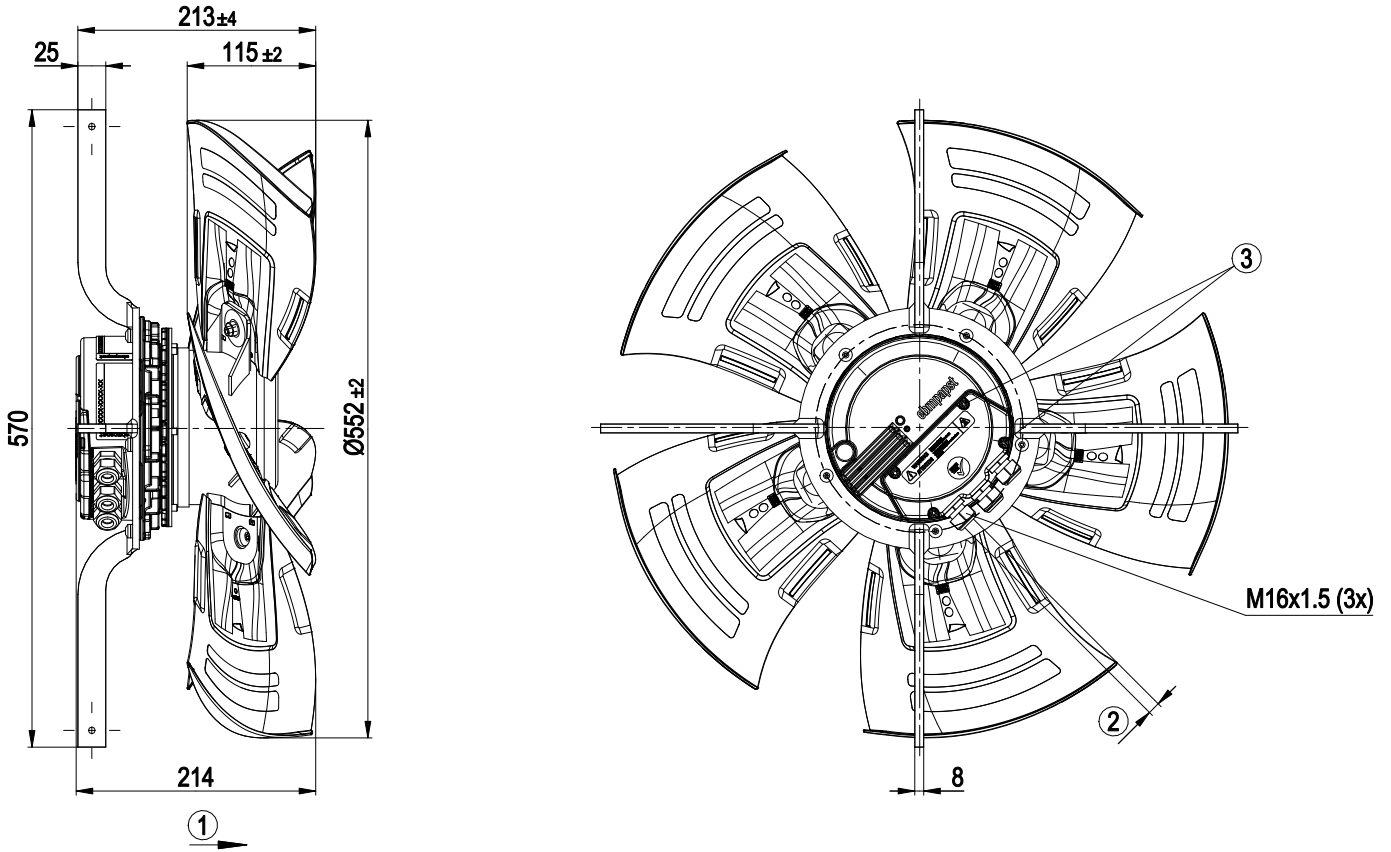

1	Direction of air flow "A"
2	Cable diameter min. 4 mm, max. 10 mm, tightening torque 2.5 ± 0.4 Nm
3	Tightening torque 3.5 ± 0.5 Nm



EC axial fan - HyBlade

sickle-shaped blades (S series)
with support ring, for barn ventilation

Connection diagram

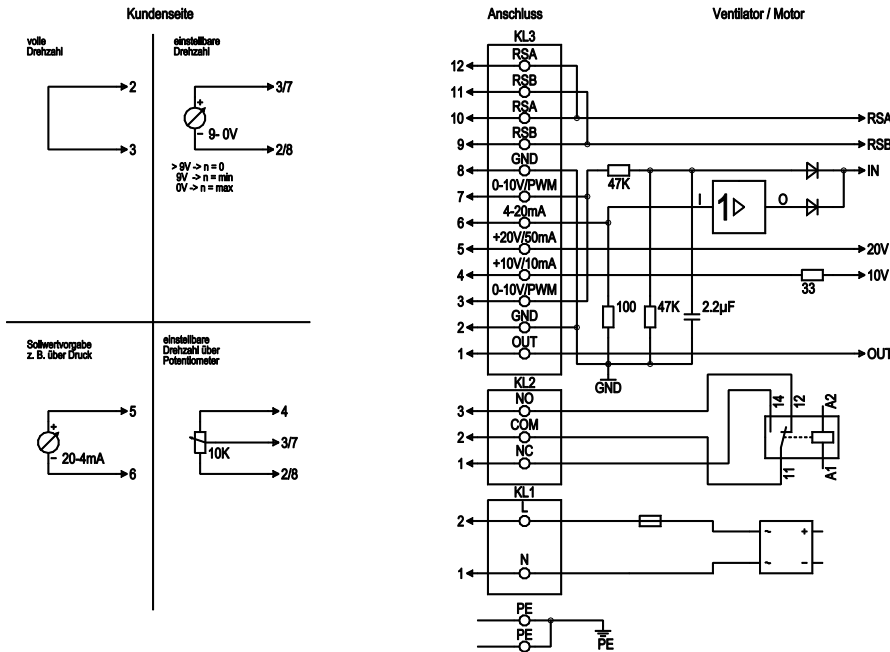

No.	Conn.	Designation	Function/assignment
PE	-	PE	Protective earth terminal
KL1	1, 2	N, L	Power supply 50/60 Hz
KL2	1	NC	Floating status contact, break for failure
KL2	2	COM	Floating status contact, changeover contact, common connection (2 A, max. 250 VAC, min. 10 mA, AC1)
KL2	3	NO	Floating status contact, make for failure
KL3	1	OUT	Analog output, 0-10 VDC, max. 3 mA, SELV output of current motor modulation level: 1 V corresponds to 10% modulation level. 10 V corresponds to 100% modulation level.
KL3	2, 8	GND	Reference ground for control interface, SELV
KL3	3, 7	0-10 V	Use control / current sensor value input 10-0 VDC, impedance 100 kΩ only as alternative to 4-20 mA input, SELV
KL3	4	+10 V	Voltage output 10 VDC (±3%), max. 10 mA, power supply for external devices (e.g. potentiometer), SELV
KL3	5	+20 V	Voltage output 20 VDC (+25%/-10%), max. 50 mA power supply for external devices (e.g. sensors), SELV
KL3	6	4-20 mA	Use control / current sensor value input 20-4 mA, impedance 100 Ω only as alternative to 0-10 V input, SELV
KL3	9, 11	RSB	RS485 interface for MODBUS, RSB
KL3	10, 12	RSA	RS485 interface for MODBUS, RSA



EC axial fan - HyBlade

sickle-shaped blades (S series)
with support ring, for barn ventilation

Curves: Air performance 50 Hz

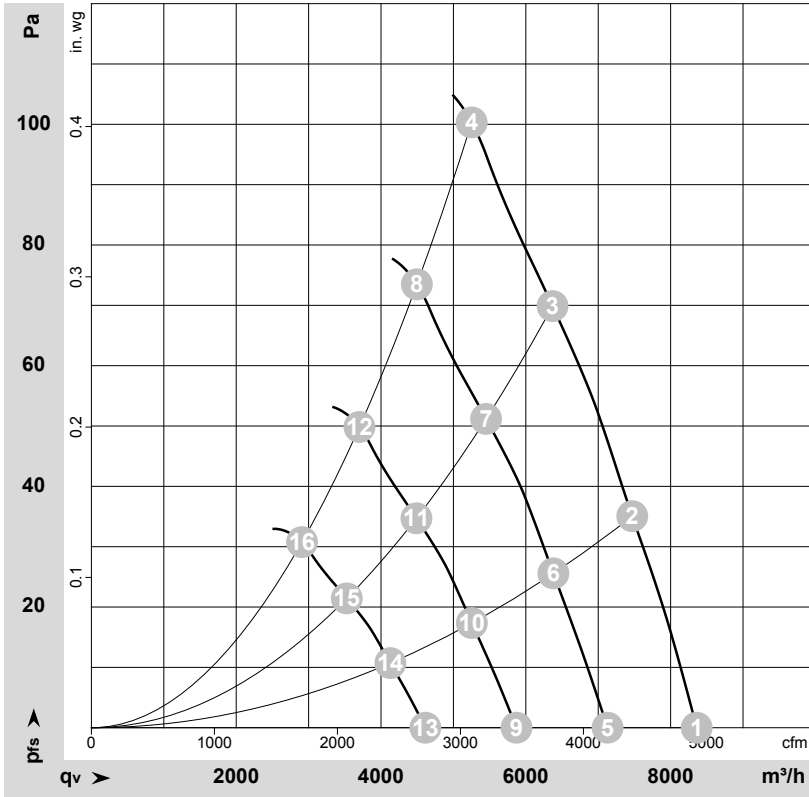

$\rho = 1.15 \text{ kg/m}^3 \pm 2 \%$

Measurement: LU-118048-1

Air performance measured according to ISO 5801 installation category A. For detailed information on the measurement setup, contact ebmpapst. Intake sound level: Sound power level according to ISO 13347 / sound pressure level measured at 1 m distance from fan axis. The values given are valid under the specified measuring conditions and may vary due to conditions of installation. For deviations from the standard configuration, the parameters have to be checked on the installed unit.

Measured values

	Wired	U	f	n	P _{ed}	I	LpA _{in}	LwA _{in}	LwA _{out}	q _v	p _{fs}	q _v	p _{fs}
		V	Hz	min ⁻¹	W	A	dB(A)	dB(A)	dB(A)	m ³ /h	Pa	cfm	in. wg
1	1~	230	50	1000	293	1.29	60	67	67	8360	0	4920	0.00
2	1~	230	50	1000	337	1.48	59	66	66	7470	35	4395	0.14
3	1~	230	50	1000	372	1.63	61	67	66	6370	70	3750	0.28
4	1~	230	50	1000	400	1.80	62	69	69	5250	100	3090	0.40
5	1~	230	50	850	182	0.80	56	63	63	7130	0	4195	0.00
6	1~	230	50	850	210	0.92	55	62	62	6380	26	3755	0.10
7	1~	230	50	850	233	1.02	57	63	62	5450	51	3210	0.20
8	1~	230	50	850	252	1.10	58	65	65	4495	74	2645	0.30
9	1~	230	50	700	102	0.45	51	58	58	5870	0	3455	0.00
10	1~	230	50	700	117	0.52	50	57	57	5255	17	3095	0.07
11	1~	230	50	700	130	0.57	52	58	57	4490	35	2640	0.14
12	1~	230	50	700	141	0.62	53	60	60	3700	50	2180	0.20
13	1~	230	50	550	49	0.22	45	52	52	4615	0	2715	0.00
14	1~	230	50	550	57	0.25	44	51	51	4130	11	2430	0.04
15	1~	230	50	550	63	0.28	46	52	51	3525	21	2075	0.08
16	1~	230	50	550	68	0.30	47	54	54	2910	31	1710	0.12

Wired = Wiring · U = Voltage · f = Frequency · n = Speed (rpm) · P_{ed} = Power consumption · I = Current draw · LpA_{in} = Sound pressure level intake side · LwA_{in} = Sound power level intake side
LwA_{out} = Sound power level outlet side · q_v = Air flow · p_{fs} = Pressure increase

