

S3G560-CQ41-05 ebmpapst Datasheet
 sales@fansco.com
 www.fansco.com

Limited partnership · Headquarters Muldingen
 Amtsgericht (court of registration) Stuttgart · HRA 590344

General partner Elektrobau Muldingen GmbH · Headquarters Muldingen
 Amtsgericht (court of registration) Stuttgart · HRB 590142



Nominal data

Type	S3G560-CQ41-05	
Motor	M3G112-GA	
Phase		3~
Nominal voltage	VAC	400
Nominal voltage range	VAC	380 .. 480
Frequency	Hz	50/60
Method of obtaining data		ml
Speed (rpm)	min ⁻¹	1350
Power consumption	W	945
Current draw	A	1.5
Max. back pressure	Pa	180
Max. back pressure	inH ₂ O	0.72
Min. ambient temperature	°C	-25
Max. ambient temperature	°C	60

ml = Max. load · me = Max. efficiency · fa = Free air · cs = Customer specification · ce = Customer equipment
 Subject to change

Data according to ErP Directive

		Actual	Req. 2015			
01 Overall efficiency η_{es}	%	42.9	33.5	09 Power consumption P_{ed}	kW	0.93
02 Measurement category		A		09 Air flow q_v	m ³ /h	7890
03 Efficiency category		Static		09 Pressure increase p_{fs}	Pa	168
04 Efficiency grade N		49.4	40	10 Speed (rpm) n	min ⁻¹	1360
05 Variable speed drive		Yes		11 Specific ratio*		1.00

Data obtained at optimum efficiency level.
 The ErP data is determined using a motor-impeller combination in a standardized measurement setup.

* Specific ratio = $1 + p_s / 100\,000\text{ Pa}$

LU-116554



Technical description

Weight	14 kg
Fan size	560 mm
Rotor surface	Painted black
Electronics housing material	Die-cast aluminum, painted black
Blade material	Sheet aluminum insert, sprayed with PP plastic
Guard grille material	Steel, coated with black plastic (RAL 9005)
Number of blades	5
Blade pitch	-5°
Airflow direction	"A"
Direction of rotation	Clockwise, viewed toward rotor
Degree of protection	IP54
Insulation class	"B"
Moisture (F) / Environmental (H) protection class	F4-1
Max. permitted ambient temp. for motor (transport/storage)	+80 °C
Min. permitted ambient temp. for motor (transport/storage)	-40 °C
Installation position	Shaft horizontal or rotor on bottom; rotor on top on request
Condensation drainage holes	On rotor side
Mode	S1
Motor bearing	Ball bearing
Technical features	<ul style="list-style-type: none"> - Output 10 VDC, max. 10 mA - Output 20 VDC, max. 50 mA - Output for slave 0-10 V - Input for sensor 0-10 V or 4-20 mA - External 24 V input (parameter setting) - Alarm relay - Integrated PID controller - Motor current limitation - PFC, passive - RS-485 MODBUS-RTU - Soft start - Control input 0-10 VDC / PWM - Control interface with SELV potential safely disconnected from supply - Thermal overload protection for electronics/motor - Line undervoltage / phase failure detection
EMC immunity to interference	According to EN 61000-6-2 (industrial environment)
EMC circuit feedback	According to EN 61000-3-2/3
EMC interference emission	According to EN 61000-6-3 (household environment)
Touch current according to IEC 60990 (measuring circuit Fig. 4, TN system)	<= 3.5 mA
Electrical hookup	Via terminal box
Motor protection	Thermal overload protector (TOP) internally connected
With cable	Variable
Protection class	I (with customer connection of protective earth)
Conformity with standards	EN 61800-5-1; CE
Approval	EAC

Product drawing

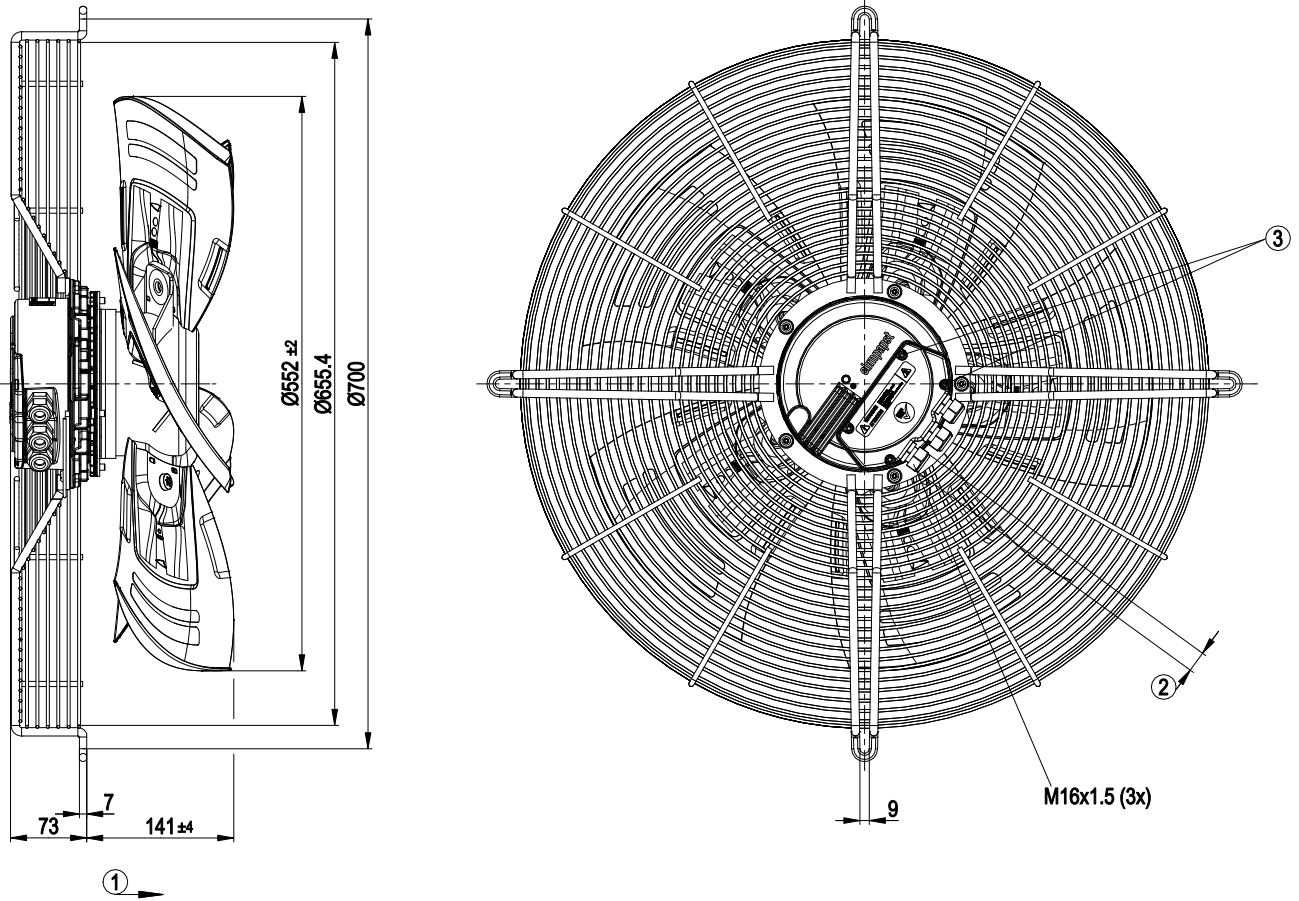

1	Direction of air flow "A"
2	Cable diameter min. 4 mm, max. 10 mm, tightening torque 2.5 ± 0.4 Nm
3	Tightening torque 3.5 ± 0.5 Nm



Connection diagram

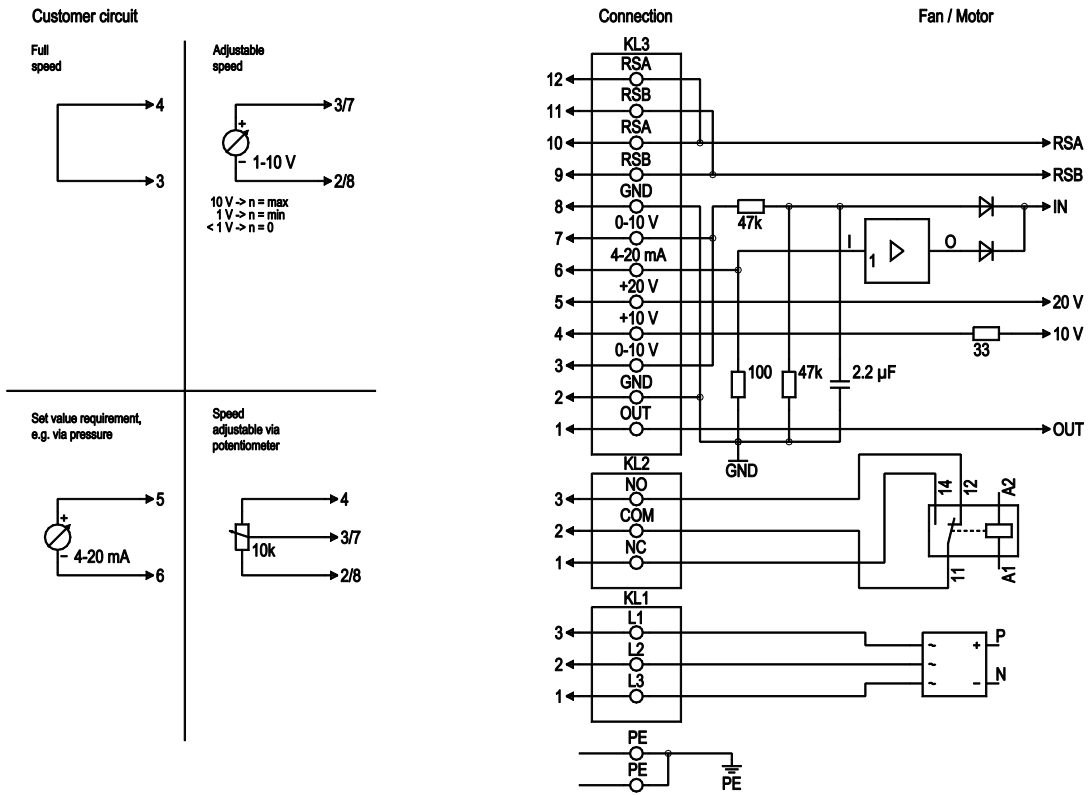

No.	Conn.	Designation	Function/assignment
PE		PE	Protective earth terminal
KL1	1, 2, 3	L1, L2, L3	Power supply, voltage range (see nameplate), 50/60 Hz
KL2	1	NC	Floating status contact, break for failure
KL2	2	COM	floating status contact, changeover contact, common connection (2 A, max. 250 VAC, min. 10 mA, AC1)
KL2	3	NO	Floating status contact, make for failure
KL3	1	OUT	Analog output, 0-10 VDC, max. 3 mA, SELV, output of current motor modulation level: 1 V corresponds to 10% modulation level. 10 V corresponds to 100% modulation level.
KL3	2, 8	GND	Reference ground for control interface, SELV
KL3	3, 7	0-10 V	Use control / current sensor value input 0-10 VDC, impedance 100 kΩ only as alternative to 4-20 mA input, SELV
KL3	4	+10 V	Voltage output 10 VDC (±3%), max. 10 mA, power supply for external devices (e.g. potentiometer), SELV
KL3	5	+20 V	Voltage output 20 VDC (+25%/-10%), max. 50 mA, power supply for external devices (e.g. sensors), SELV
KL3	6	4-20 mA	Use control / current sensor value input 4-20 mA, impedance 100 Ω only as alternative to 0-10 V input, SELV
KL3	9, 11	RSB	RS485 interface for MODBUS, RSB
KL3	10, 12	RSA	RS485 interface for MODBUS, RSA



Curves: Air performance 50 Hz

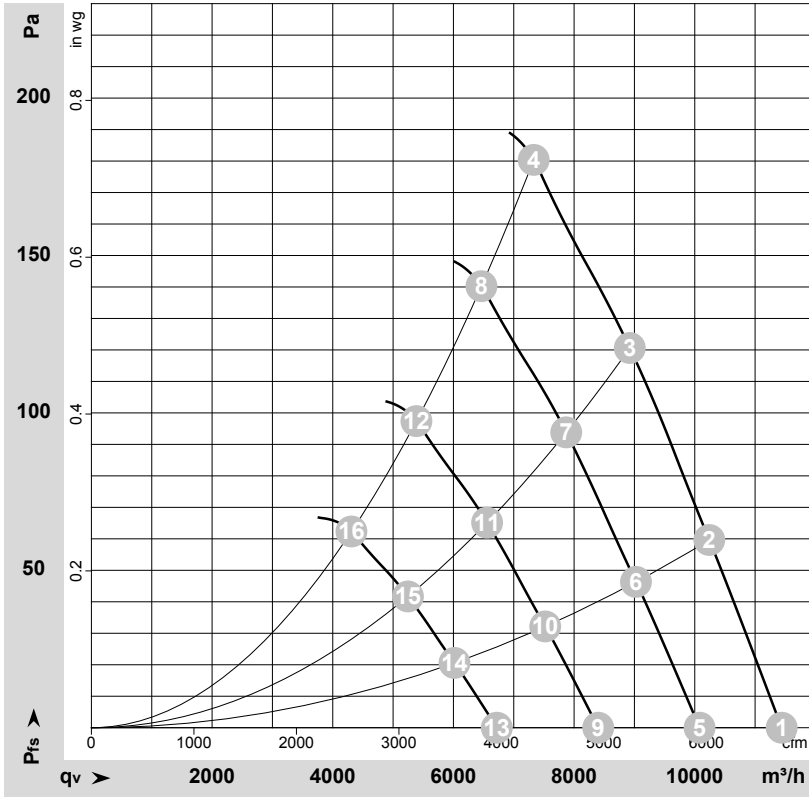

$\rho = 1.15 \text{ kg/m}^3 \pm 2 \%$

Measurement: LU-119233-1

Air performance measured according to ISO 5801 installation category A. For detailed information on the measurement setup, contact ebm-papst. Intake sound level: Sound power level according to ISO 13347 / sound pressure level measured at 1 m distance from fan axis. The values given are valid under the specified measuring conditions and may vary due to conditions of installation. For deviations from the standard configuration, the parameters have to be checked on the installed unit.

Measured values

	U	f	n	P _{ed}	I	LpA _{in}	LwA _{in}	LwA _{out}	qv	P _{fs}	qv	P _{fs}
	V	Hz	min ⁻¹	W	A	dB(A)	dB(A)	dB(A)	m ³ /h	Pa	CFM	inH ₂ O
1	400	50	1350	673	1.11	68	75	75	11440	0	6735	0.00
2	400	50	1350	784	1.26	67	74	74	10240	60	6030	0.24
3	400	50	1350	869	1.38	68	74	74	8925	120	5250	0.48
4	400	50	1350	945	1.50	70	77	76	7330	180	4315	0.72
5	400	50	1200	460	0.76	65	71	72	10080	0	5935	0.00
6	400	50	1200	537	0.86	64	71	70	9025	46	5315	0.18
7	400	50	1200	596	0.95	65	71	70	7870	94	4630	0.38
8	400	50	1200	648	1.02	67	74	73	6465	141	3805	0.57
9	400	50	1000	266	0.44	60	67	67	8400	0	4945	0.00
10	400	50	1000	311	0.50	59	66	66	7520	32	4425	0.13
11	400	50	1000	345	0.55	60	66	66	6560	65	3860	0.26
12	400	50	1000	375	0.59	62	69	69	5385	98	3170	0.39
13	400	50	800	136	0.23	54	61	61	6720	0	3955	0.00
14	400	50	800	159	0.26	54	60	60	6015	21	3540	0.08
15	400	50	800	177	0.28	54	61	60	5245	42	3090	0.17
16	400	50	800	192	0.30	57	64	63	4310	63	2535	0.25

U = Power supply · f = Frequency · n = Speed (rpm) · P_{ed} = Power consumption · I = Current draw · LpA_{in} = Sound pressure level intake side · LwA_{in} = Sound power level intake side
 LwA_{out} = Sound power level outlet side · qv = Air flow · p_{fs} = Pressure increase

