

S3G560-CL12-H6 ebmpapst Datasheet

sales@fansco.com

www.fansco.com

Limited partnership · Headquarters Mulfingen

Amtsgericht (court of registration) Stuttgart · HRA 590344

General partner Elektrobau Mulfingen GmbH · Headquarters Mulfingen

Amtsgericht (court of registration) Stuttgart · HRB 590142

## Nominal data

Type	S3G560-CL12-H6	
Motor	M3G084-FA	
Phase		1~
Nominal voltage	VAC	230
Nominal voltage range	VAC	200 .. 277
Frequency	Hz	50/60
Method of obtaining data		ml
Status		prelim.
Speed (rpm)	min <sup>-1</sup>	1200
Power consumption	W	500
Current draw	A	2.2
Max. back pressure	Pa	100
Max. back pressure	in. wg	0.4
Min. ambient temperature	°C	-25
Max. ambient temperature	°C	60

ml = Max. load · me = Max. efficiency · fa = Free air · cs = Customer specification · ce = Customer equipment  
Subject to change

## Data according to Commission Regulation (EU) 327/2011 (EN 17166)

		Actual	Req. 2015		
01 Overall efficiency $\eta_{es}$	%	42.6	31.8	09 Power consumption $P_{ed}$	kW 0.5
02 Measurement category		A		09 Air flow $q_v$	m <sup>3</sup> /h 6425
03 Efficiency category		Static		09 Pressure increase $p_{fs}$	Pa 110
04 Efficiency grade N		50.8	40	10 Speed (rpm) n	min <sup>-1</sup> 1170
05 Variable speed drive		Yes		11 Specific ratio*	1.00

Data obtained at optimum efficiency level.

The ErP data is determined using a motor-impeller combination in a standardized measurement setup.

\* Specific ratio =  $1 + p_g / 100\,000\text{ Pa}$ 

LU-197770



## Technical description

<b>Weight</b>	9 kg
<b>Size</b>	560 mm
<b>Motor size</b>	84
<b>Rotor surface</b>	Painted black
<b>Terminal box material</b>	PP plastic
<b>Electronics housing material</b>	Die-cast aluminum, painted black
<b>Blade material</b>	Press-fitted sheet steel blank, sprayed with PP plastic
<b>Guard grille material</b>	Steel, coated with black plastic (RAL 9005)
<b>Number of blades</b>	5
<b>Airflow direction</b>	A
<b>Direction of rotation</b>	Clockwise, viewed toward rotor
<b>Degree of protection</b>	IP55
<b>Insulation class</b>	"F"
<b>Moisture (F) / Environmental (H) protection class</b>	H2
<b>Max. permitted ambient temp. for motor (transport/storage)</b>	+80 °C
<b>Min. permitted ambient temp. for motor (transport/storage)</b>	-40 °C
<b>Installation position</b>	Shaft horizontal or rotor on bottom; rotor on top on request
<b>Condensation drainage holes</b>	On rotor side
<b>Mode</b>	S1
<b>Motor bearing</b>	Ball bearing
<b>Technical features</b>	<ul style="list-style-type: none"> <li>- Output 10 VDC, max. 10 mA</li> <li>- Operation and alarm display</li> <li>- Alarm relay</li> <li>- Integrated PID controller</li> <li>- Power limiter</li> <li>- Motor current limitation</li> <li>- PFC, active</li> <li>- RS-485 MODBUS-RTU</li> <li>- Soft start</li> <li>- Control input 0-10 VDC / PWM</li> <li>- Control interface with SELV potential safely disconnected from the mains</li> <li>- Thermal overload protection for electronics/motor</li> <li>- Line undervoltage / phase failure detection</li> </ul>
<b>Electrical hookup</b>	Terminal box with cable
<b>Motor protection</b>	Thermal overload protector (TOP) internally connected
<b>Protection class</b>	I (with customer connection of protective earth)
<b>Conformity with standards</b>	EN 61800-5-1; CE
<b>Approval</b>	UL 1004-7 + 60730-1; CSA C22.2 No. 77 + CAN/CSA-E60730-1; EAC

# EC axial fan - HyBlade

sickle-shaped blades (S series)

with guard grille for full nozzle

## Product drawing

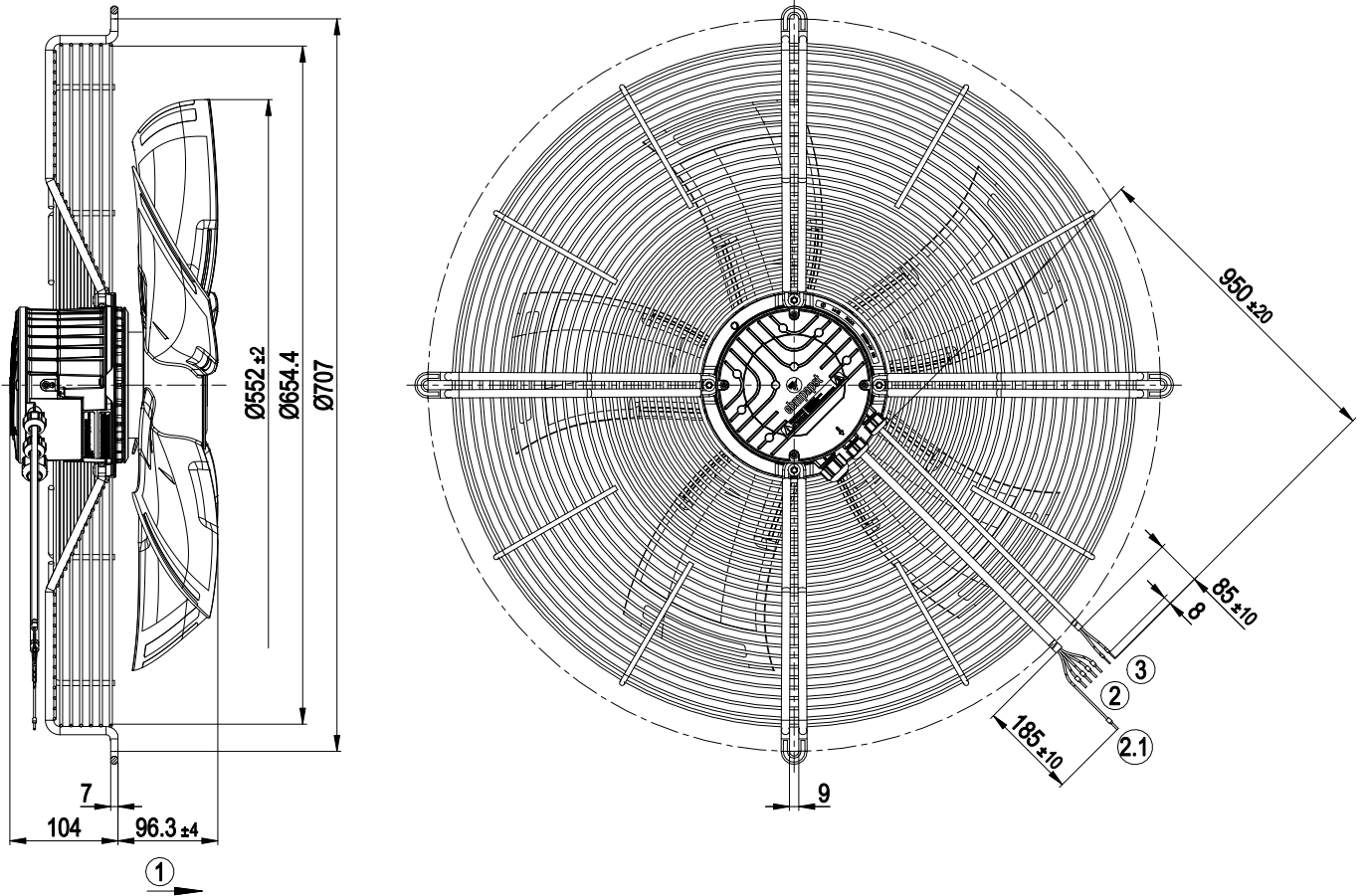

1	Direction of air flow "A"
2	Cable PVC AWG18
	5x wire-end ferrule
2.1	PE
3	Cable PVC AWG22
	2x wire-end ferrule



# EC axial fan - HyBlade

sickle-shaped blades (S series)

with guard grille for full nozzle

## Connection diagram

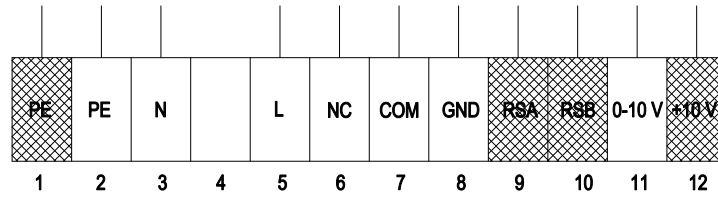

shaded gray => not brought out via leads

No.	Conn.	Designation	Function/assignment
1	PE	PE	Protective earth
2	PE	PE	Protective earth
3	N	N	Power supply, neutral conductor
4	-	-	not used
5	L	L	Power supply, phase
6	NC	NC	Status relay, floating status contact, break for failure, contact rating 250 VAC / 2 A (AC1) / min. 10 mA; basic insulation on supply side and reinforced insulation on control interface side
7	COM	COM	Status relay, floating status contact, common connection, contact rating 250 VAC / 2 A (AC1) / min. 10 mA; basic insulation on supply side and reinforced insulation on control interface side
8	GND	GND	Reference ground for control interface, SELV
9	RSA	RSA	RS485 interface for MODBUS, RSA; SELV
10	RSB	RSB	RS485 interface for MODBUS, RSB; SELV
11	0-10 V	0-10 V	Analog input (set value) SELV, 0-10 V, Ri = 100 kΩ, adjustable curve
12	+10 V	+10 V	Fixed voltage output 10 VDC, SELV, +10 V ±3%, max. 10 mA, short-circuit-proof, power supply for external devices (e.g. potentiometer)



# EC axial fan - HyBlade

sickle-shaped blades (S series)

with guard grille for full nozzle

## Curves: Air performance 50 Hz

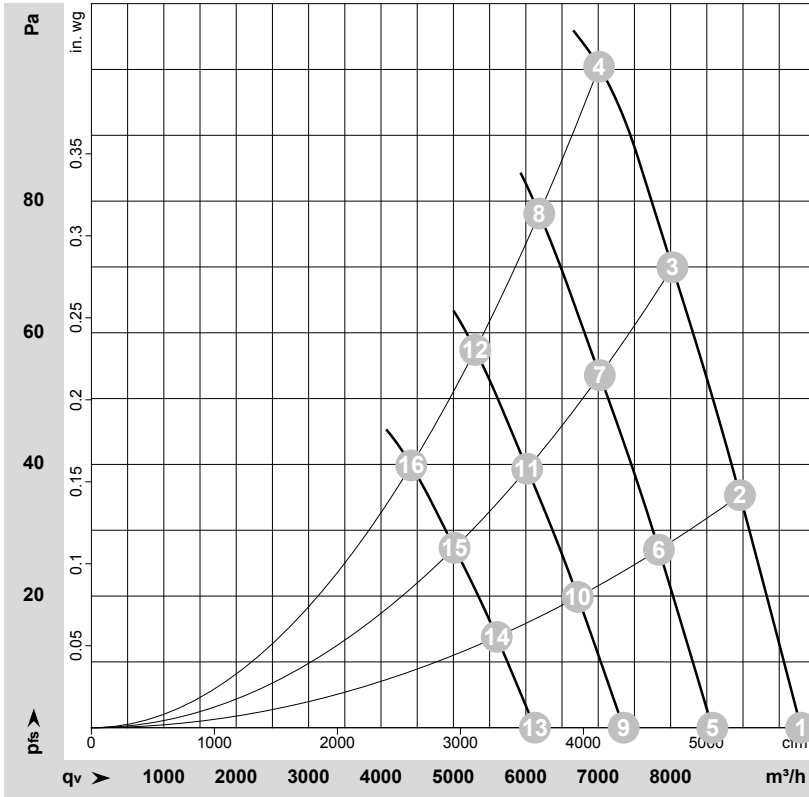

$\rho = 1.15 \text{ kg/m}^3 \pm 2 \%$

Measurement: LU-197770-1

Air performance measured according to ISO 5801 installation category A. For detailed information on the measurement setup, contact ebmpapst. Intake sound level: Sound power level according to ISO 13347 / sound pressure level measured at 1 m distance from fan axis. The values given are valid under the specified measuring conditions and may vary due to conditions of installation. For deviations from the standard configuration, the parameters have to be checked on the installed unit.

## Measured values

	Wired	U	f	n	P <sub>ed</sub>	I	LpA <sub>in</sub>	LwA <sub>in</sub>	LwA <sub>out</sub>	q <sub>v</sub>	p <sub>fs</sub>	q <sub>v</sub>	p <sub>fs</sub>
		V	Hz	min <sup>-1</sup>	W	A	dB(A)	dB(A)	dB(A)	m <sup>3</sup> /h	Pa	cfm	in. wg
1	1~	230	50	1200	377	1.66	69	76	76	9800	0	5770	0.00
2	1~	230	50	1200	435	1.91	69	75	76	8960	35	5270	0.14
3	1~	230	50	1200	479	2.10	69	76	76	8025	70	4725	0.28
4	1~	230	50	1200	500	2.20	68	75	75	7010	100	4125	0.40
5	1~	230	50	1050	253	1.11	66	73	73	8575	0	5050	0.00
6	1~	230	50	1050	291	1.28	65	72	72	7840	27	4615	0.11
7	1~	230	50	1050	321	1.41	66	72	73	7020	54	4135	0.22
8	1~	230	50	1050	351	1.54	65	72	72	6185	78	3640	0.31
9	1~	230	50	900	159	0.70	62	69	69	7350	0	4325	0.00
10	1~	230	50	900	183	0.80	61	68	68	6720	20	3955	0.08
11	1~	230	50	900	202	0.88	62	68	69	6020	39	3545	0.16
12	1~	230	50	900	221	0.97	61	68	68	5300	57	3120	0.23
13	1~	230	50	750	92	0.40	57	64	64	6125	0	3605	0.00
14	1~	230	50	750	106	0.47	57	64	64	5600	14	3295	0.06
15	1~	230	50	750	117	0.51	57	64	64	5015	27	2950	0.11
16	1~	230	50	750	128	0.56	56	63	64	4420	40	2600	0.16

Wired = Wiring · U = Voltage · f = Frequency · n = Speed (rpm) · P<sub>ed</sub> = Power consumption · I = Current draw · LpA<sub>in</sub> = Sound pressure level intake side · LwA<sub>in</sub> = Sound power level intake side  
 LwA<sub>out</sub> = Sound power level outlet side · q<sub>v</sub> = Air flow · p<sub>fs</sub> = Pressure increase

