

EC axial fan - HyBlade

sickle-shaped blades (S series)

with guard grille for short nozzle

S3G560-AP68-22 ebmpapst Datasheet

sales@fansco.com

www.fansco.com

Limited partnership · Headquarters Mulfingen

Amtsgericht (court of registration) Stuttgart · HRA 590344

General partner Elektrobau Mulfingen GmbH · Headquarters Mulfingen

Amtsgericht (court of registration) Stuttgart · HRB 590142

Nominal data

Type	S3G560-AP68-22	
Motor	M3G112-EA	
Phase		1~
Nominal voltage	VAC	230
Nominal voltage range	VAC	200 .. 277
Frequency	Hz	50/60
Method of obtaining data		ml
Speed (rpm)	min ⁻¹	1000
Power consumption	W	400
Current draw	A	1.8
Max. back pressure	Pa	100
Max. back pressure	inH ₂ O	0.4
Min. ambient temperature	°C	-25
Max. ambient temperature	°C	60

ml = Max. load · me = Max. efficiency · fa = Free air · cs = Customer specification · ce = Customer equipment
Subject to change

Data according to Commission Regulation (EU) 327/2011

		Actual	Req. 2015			
01 Overall efficiency η_{es}	%	41.1	31.2	09 Power consumption P_{ed}	kW	0.4
02 Measurement category		A		09 Air flow q_v	m ³ /h	5245
03 Efficiency category		Static		09 Pressure increase p_{fs}	Pa	102
04 Efficiency grade N		49.9	40	10 Speed (rpm) n	min ⁻¹	995
05 Variable speed drive		Yes		11 Specific ratio*		1.00

Data obtained at optimum efficiency level.

The ErP data is determined using a motor-impeller combination in a standardized measurement setup.

* Specific ratio = $1 + p_s / 100\,000\text{ Pa}$

LU-118048



Technical description

Weight	12.4 kg
Fan size	560 mm
Rotor surface	Painted black
Electronics housing material	Die-cast aluminum, painted black
Blade material	Sheet aluminum insert, sprayed with PP plastic
Guard grille material	Steel, phosphated and coated with black plastic
Number of blades	5
Airflow direction	"A"
Direction of rotation	Clockwise, viewed toward rotor
Degree of protection	IP54
Insulation class	"B"
Moisture (F) / Environmental (H) protection class	F4-1
Max. permitted ambient temp. for motor (transport/storage)	Max. +80 °C
Min. permitted ambient temp. for motor (transport/storage)	Min. -40 °C
Installation position	Shaft horizontal or rotor on bottom; rotor on top on request
Condensation drainage holes	On rotor side
Mode	S1
Motor bearing	Ball bearing
Technical features	<ul style="list-style-type: none"> - Thermal overload protection for electronics/motor - Alarm relay - PFC, active - Motor current limitation - Soft start - Undervoltage/phase failure detection - Output 10 VDC, max. 10 mA - Control input 0-10 V
EMC immunity to interference	According to EN 61000-6-2 (industrial environment)
EMC circuit feedback	According to EN 61000-3-2/3
EMC interference emission	According to EN 61000-6-4 (industrial environment)
Touch current according to IEC 60990 (measuring circuit Fig. 4, TN system)	<= 3.5 mA
Motor protection	Thermal overload protector (TOP) internally connected
With cable	Variable
Protection class	I (with customer connection of protective earth)
Conformity with standards	CE
Approval	EAC

EC axial fan - HyBlade

sickle-shaped blades (S series)
with guard grille for short nozzle

Product drawing

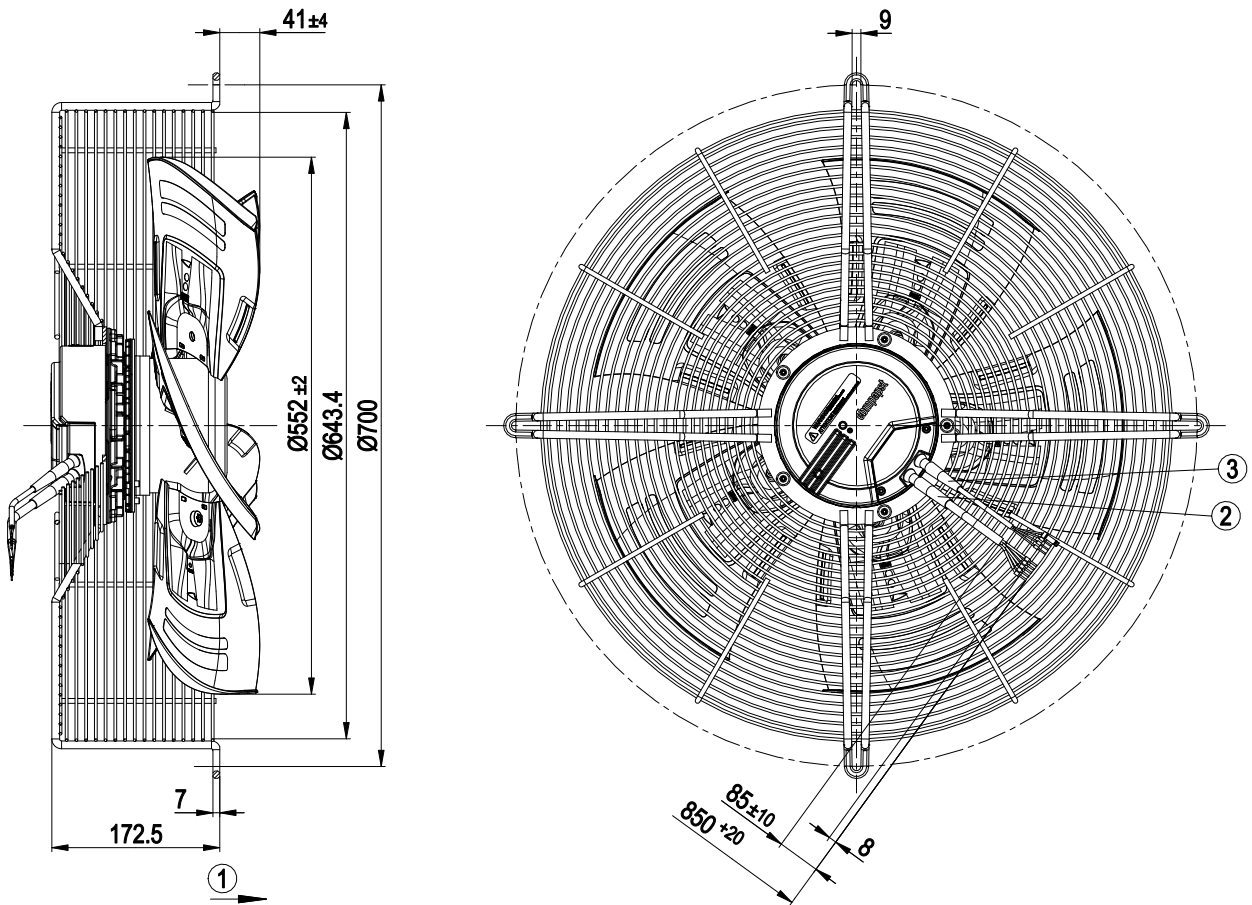

1	Direction of air flow "A"
2	Cable PVC AWG18, 5x crimped ferrules
3	Cable PVC AWG22, 3x ferrules 1x end connector crimped



EC axial fan - HyBlade

sickle-shaped blades (S series)
with guard grille for short nozzle

Connection diagram

Customer circuit

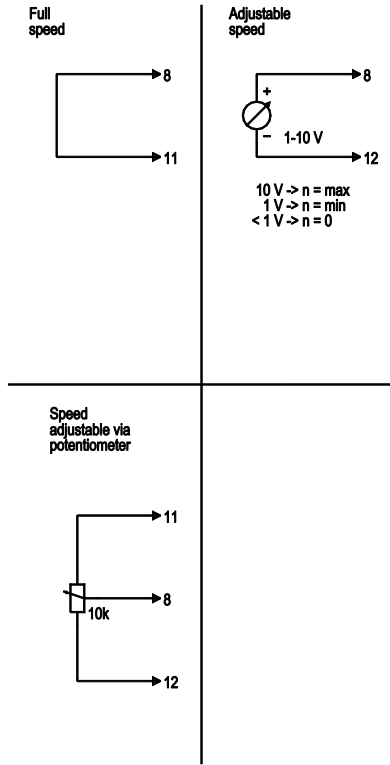

Connection

Fan/Motor

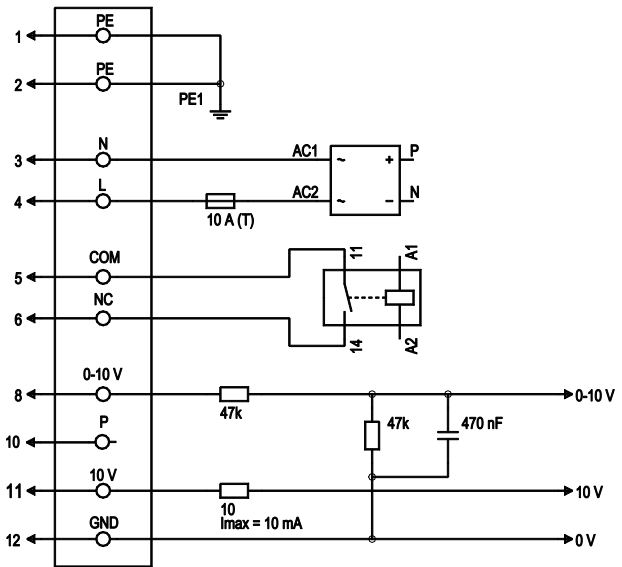

No.	Conn.	Designation	Color	Function/assignment
1	1,2	PE	green/yellow	Protective earth
1	3	N	blue	Power supply, neutral conductor, 50/60 Hz
1	4	L	black	Power supply, phase, 50/60 Hz
1	5	COM	white 1	Floating status contact, break for failure (2 A, max. 250 VAC, min. 10 mA, AC1)
1	6	NC	white 2	Floating status contact, break for failure
2	8	0-10 V	yellow	Control input, set value 0-10 VDC, impedance 100 kΩ, SELV
2	10	P	orange	not used
2	11	10 VDC	red	Voltage output 10 VDC (±3%), max. 10 mA, power supply for external devices (e.g. potentiometer), SELV
2	12	GND	blue	Reference ground for control interface, SELV



EC axial fan - HyBlade

sickle-shaped blades (S series)
with guard grille for short nozzle

Curves: Air performance 50 Hz

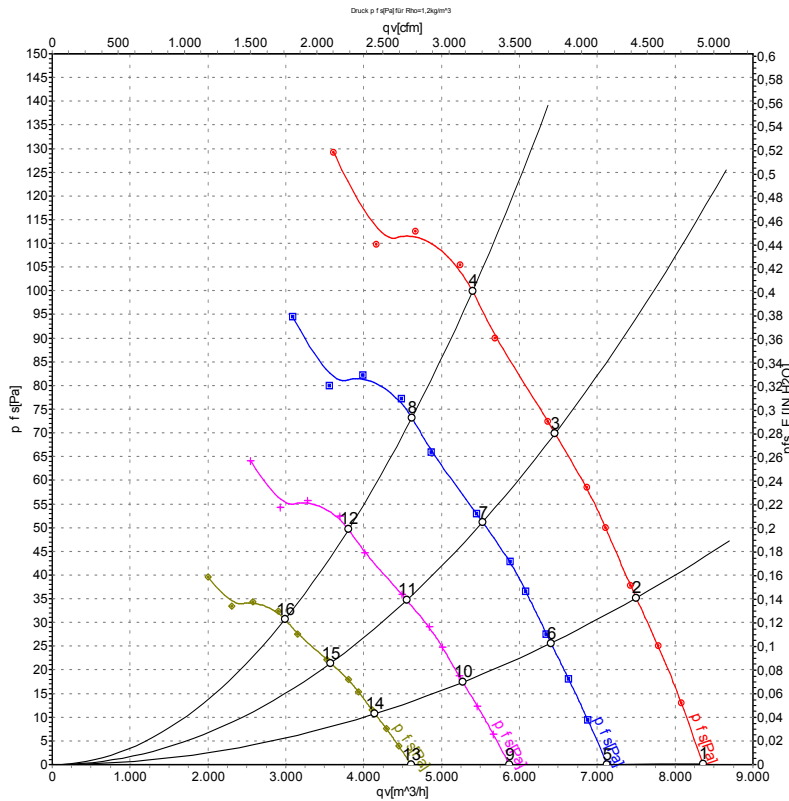

Measurement: LU-118048-1

Air performance measured according to ISO 5801 installation category A. For detailed information on the measurement setup, contact ebmpapst. Intake sound level: Sound power level according to ISO 13347 / sound pressure level measured at 1 m distance from fan axis. The values given are valid under the specified measuring conditions and may vary due to conditions of installation. For deviations from the standard configuration, the parameters have to be checked on the installed unit.

Measured values

	U	f	n	P _{ed}	I	LpA _{in}	LwA _{in}	LwA _{out}	q _v	P _{fs}	q _v	P _{fs}
	V	Hz	min ⁻¹	W	A	dB(A)	dB(A)	dB(A)	m ³ /h	Pa	cfm	inH ₂ O
1	230	50	1000	293	1.29	60	67	67	8360	0	4920	0.00
2	230	50	1000	336	1.48	59	66	66	7500	35	4415	0.14
3	230	50	1000	369	1.61	60	67	66	6460	70	3800	0.28
4	230	50	1000	400	1.80	62	69	68	5400	100	3175	0.40
5	230	50	850	182	0.80	57	64	64	7130	0	4195	0.00
6	230	50	850	209	0.92	56	63	62	6405	26	3770	0.10
7	230	50	850	231	1.01	57	63	62	5530	51	3255	0.20
8	230	50	850	249	1.09	59	65	65	4620	73	2720	0.29
9	230	50	700	102	0.45	53	59	59	5870	0	3455	0.00
10	230	50	700	117	0.51	52	58	58	5275	17	3105	0.07
11	230	50	700	129	0.57	52	59	58	4550	35	2680	0.14
12	230	50	700	139	0.61	55	61	61	3805	50	2240	0.20
13	230	50	550	49	0.22	47	54	54	4610	0	2715	0.00
14	230	50	550	57	0.25	46	53	53	4145	11	2440	0.04
15	230	50	550	63	0.27	47	54	53	3575	21	2105	0.08
16	230	50	550	68	0.30	49	56	55	2990	31	1760	0.12

U = Power supply · f = Frequency · n = Speed (rpm) · P_{ed} = Power consumption · I = Current draw · LpA_{in} = Sound pressure level intake side · LwA_{in} = Sound power level intake side
LwA_{out} = Sound power level outlet side · q_v = Air flow · P_{fs} = Pressure increase

