

EC axial fan - HyBlade

sickle-shaped blades (S series)

with guard grille for full nozzle

S3G500-CF48-53 ebmpapst Datasheet

sales@fansco.com

www.fansco.com

Limited partnership · Headquarters Mulfingen

Amtsgericht (court of registration) Stuttgart · HRA 590344

General partner Elektrobau Mulfingen GmbH · Headquarters Mulfingen

Amtsgericht (court of registration) Stuttgart · HRB 590142

Nominal data

Type	S3G500-CF48-53	
Motor	M3G084-DF	
Phase		1~
Nominal voltage	VAC	230
Nominal voltage range	VAC	200 .. 277
Frequency	Hz	50/60
Method of obtaining data		ml
Speed (rpm)	min ⁻¹	870
Power consumption	W	180
Current draw	A	1.2
Max. back pressure	Pa	70
Max. back pressure	in. wg	0.28
Min. ambient temperature	°C	-25
Max. ambient temperature	°C	65

ml = Max. load · me = Max. efficiency · fa = Free air · cs = Customer specification · ce = Customer equipment
Subject to change

Data according to Commission Regulation (EU) 327/2011 (EN 17166)

		Actual	Req. 2015			
01 Overall efficiency η_{es}	%	40.2	29.1	09 Power consumption P_{ed}	kW	0.18
02 Measurement category		A		09 Air flow q_v	m ³ /h	3995
03 Efficiency category		Static		09 Pressure increase p_{fs}	Pa	59
04 Efficiency grade N		51.1	40	10 Speed (rpm) n	min ⁻¹	890
05 Variable speed drive		Yes		11 Specific ratio*		1.00

Data obtained at optimum efficiency level.

The ErP data is determined using a motor-impeller combination in a standardized measurement setup.

* Specific ratio = $1 + p_{fs} / 100\,000\text{ Pa}$

LU-192545



EC axial fan - HyBlade

sickle-shaped blades (S series)

with guard grille for full nozzle

Technical description

Weight	6.29 kg
Size	500 mm
Motor size	84
Rotor surface	Painted black
Electronics housing material	Die-cast aluminum
Blade material	Press-fitted sheet steel blank, sprayed with PP plastic
Guard grille material	Steel, coated with black plastic (RAL 9005)
Number of blades	5
Airflow direction	V
Direction of rotation	Counterclockwise, viewed toward rotor
Degree of protection	IP54
Insulation class	"B"
Moisture (F) / Environmental (H) protection class	H2+
Max. permitted ambient temp. for motor (transport/storage)	+80 °C
Min. permitted ambient temp. for motor (transport/storage)	-40 °C
Installation position	Shaft horizontal or rotor on bottom; rotor on top on request
Condensation drainage holes	On rotor side
Mode	S1
Motor bearing	Ball bearing
Technical features	<ul style="list-style-type: none"> - Motor current limitation - Soft start - Control input 0-10 VDC / PWM - Control interface with SELV potential safely disconnected from the mains - Thermal overload protection for electronics/motor
EMC immunity to interference	According to EN 61000-6-2 (industrial environment)
EMC circuit feedback	According to EN 61000-3-2/3
EMC interference emission	According to EN 61000-6-3 (household environment)
Touch current according to IEC 60990 (measuring circuit Fig. 4, TN system)	<= 3.5 mA
Electrical hookup	Connector with cable
Motor protection	Thermal overload protector (TOP) internally connected
With cable	Variable
Protection class	I (with customer connection of protective earth)
Conformity with standards	EN 60335-1; CE



EC axial fan - HyBlade

sickle-shaped blades (S series)

with guard grille for full nozzle

Product drawing

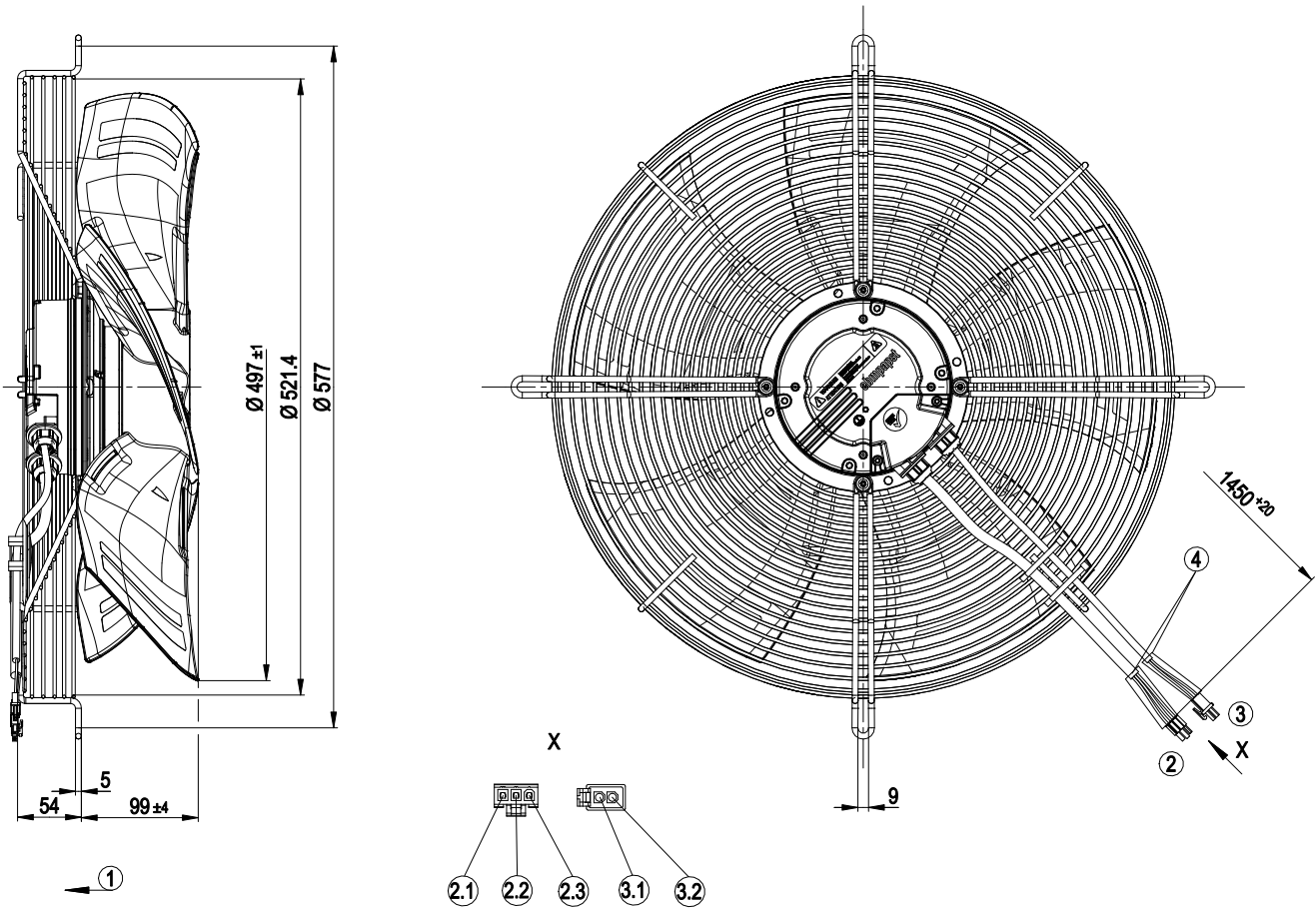

1	Direction of air flow "V"
2	Cable PVC AWG 18, with 3-pole connector housing Molex 39-01-4030, 3x socket Molex 39-00-0038
2.1	N (blue)
2.2	PE (green/yellow)
2.3	L (black)
3	Cable PVC AWG22 with 2-pole connector housing TE 794894-3, 2x socket contact 170362-1
3.1	GND (blue)
3.2	0-10 V/PWM (yellow)
4	Sealing hose



EC axial fan - HyBlade

sickle-shaped blades (S series)

with guard grille for full nozzle

Connection diagram

Customer circuit

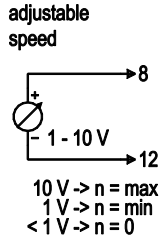

Connection

Fan/Motor

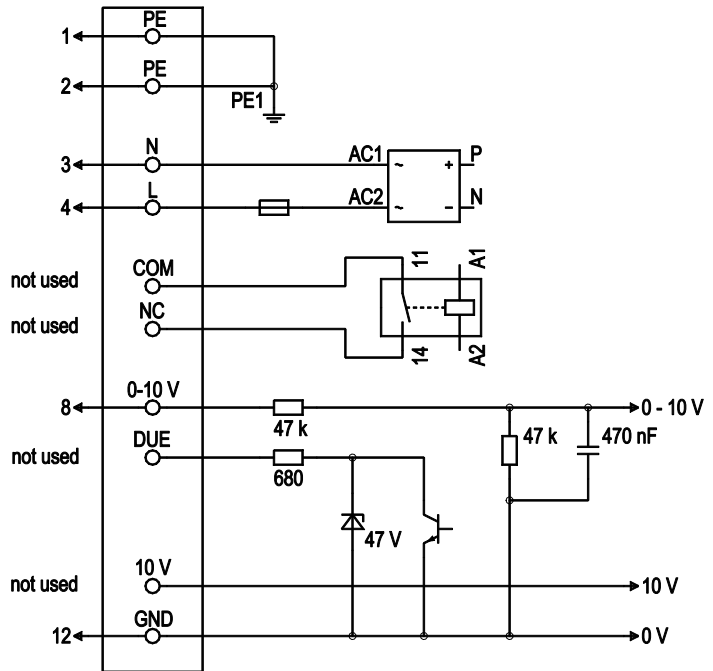

No.	Conn.	Designation	Color	Function/assignment
1	1,2	PE	green/yellow	Protective earth
1	3	N	blue	Power supply, neutral conductor, 50/60 Hz
1	4	L	black	Power supply, phase, 50/60 Hz
2	8	0 - 10 V	yellow	Control input, set value 0-10 VDC, impedance 100 kohms, SELV
2	12	GND	blue	Reference ground for control interface, SELV



Curves: Air performance 50 Hz

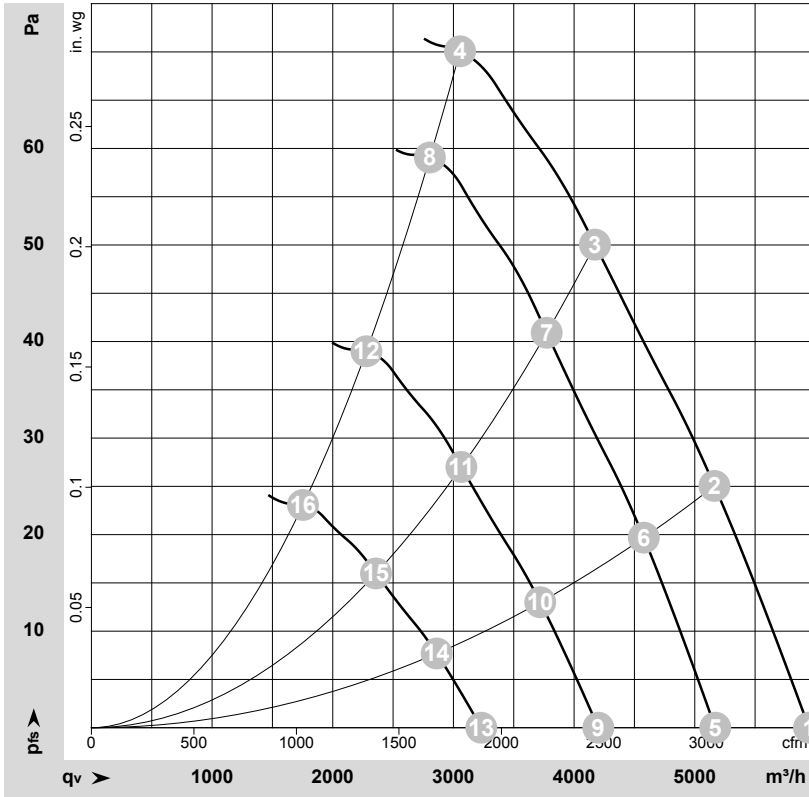

$\rho = 1.15 \text{ kg/m}^3 \pm 2 \%$

Measurement: LU-118060-1

Air performance measured according to ISO 5801 installation category A. For detailed information on the measurement setup, contact ebmpapst. Intake sound level: Sound power level according to ISO 13347 / sound pressure level measured at 1 m distance from fan axis. The values given are valid under the specified measuring conditions and may vary due to conditions of installation. For deviations from the standard configuration, the parameters have to be checked on the installed unit.

Measured values

	Wired	U	f	n	P _{ed}	I	LpA _{in}	LwA _{in}	LwA _{out}	q _v	p _{fs}	q _v	p _{fs}
		V	Hz	min ⁻¹	W	A	dB(A)	dB(A)	dB(A)	m ³ /h	Pa	cfm	in. wg
1	1~	230	50	920	152	0.97	61	68	67	5945	0	3500	0.00
2	1~	230	50	900	166	1.05	57	64	63	5165	25	3040	0.10
3	1~	230	50	885	176	1.12	53	60	60	4175	50	2455	0.20
4	1~	230	50	870	180	1.20	57	64	64	3055	70	1800	0.28
5	1~	230	50	800	100	0.64	58	64	63	5170	0	3045	0.00
6	1~	230	50	800	116	0.73	54	61	60	4580	20	2695	0.08
7	1~	230	50	800	130	0.82	51	58	57	3775	41	2220	0.16
8	1~	230	50	800	143	0.90	54	62	61	2805	59	1650	0.24
9	1~	230	50	650	54	0.34	52	59	58	4200	0	2475	0.00
10	1~	230	50	650	62	0.39	49	55	55	3720	13	2190	0.05
11	1~	230	50	650	70	0.44	46	52	52	3065	27	1805	0.11
12	1~	230	50	650	77	0.48	49	57	56	2280	39	1340	0.16
13	1~	230	50	500	24	0.16	46	52	52	3230	0	1900	0.00
14	1~	230	50	500	28	0.18	42	49	48	2860	8	1685	0.03
15	1~	230	50	500	32	0.20	39	46	45	2360	16	1390	0.06
16	1~	230	50	500	35	0.22	43	50	50	1755	23	1030	0.09

Wired = Wiring · U = Voltage · f = Frequency · n = Speed (rpm) · P_{ed} = Power consumption · I = Current draw · LpA_{in} = Sound pressure level intake side · LwA_{in} = Sound power level intake side · LwA_{out} = Sound power level outlet side · q_v = Air flow · p_{fs} = Pressure increase

