

S3G500-BD01-53 ebmpapst Datasheet

sales@fansco.com

www.fansco.com

Limited partnership · Headquarters Mulfingen

Amtsgericht (court of registration) Stuttgart · HRA 590344

General partner Elektrobau Mulfingen GmbH · Headquarters Mulfingen

Amtsgericht (court of registration) Stuttgart · HRB 590142

## Nominal data

Type	S3G500-BD01-53	
Motor	M3G084-GF	
Phase		1~
Nominal voltage	VAC	230
Nominal voltage range	VAC	200 .. 277
Frequency	Hz	50/60
Method of obtaining data		ml
Speed (rpm)	min <sup>-1</sup>	1100
Power consumption	W	360
Current draw	A	2.2
Max. back pressure	Pa	100
Max. back pressure	inH <sub>2</sub> O	0.4
Min. ambient temperature	°C	-25
Max. ambient temperature	°C	55

ml = Max. load · me = Max. efficiency · fa = Free air · cs = Customer specification · ce = Customer equipment  
Subject to change

## Data according to ErP Directive

		Actual	Req. 2015			
01 Overall efficiency $\eta_{es}$	%	40.8	30.9	09 Power consumption $P_{ed}$	kW	0.36
02 Measurement category		A		09 Air flow $q_v$	m <sup>3</sup> /h	4585
03 Efficiency category		Static		09 Pressure increase $p_{fs}$	Pa	106
04 Efficiency grade N		49.9	40	10 Speed (rpm) n	min <sup>-1</sup>	1105
05 Variable speed drive		Yes		11 Specific ratio*		1.00

Data obtained at optimum efficiency level.

The ErP data is determined using a motor-impeller combination in a standardized measurement setup.

\* Specific ratio =  $1 + p_s / 100\,000\text{ Pa}$ 

LU-114485



# EC axial fan - HyBlade

sickle-shaped blades (S series)

with guard grille for full nozzle

## Technical description

<b>Weight</b>	7.5 kg
<b>Fan size</b>	500 mm
<b>Rotor surface</b>	Painted black
<b>Terminal box material</b>	PC/ABS plastic
<b>Electronics housing material</b>	Die-cast aluminum, painted black
<b>Blade material</b>	Press-fitted sheet steel blank, sprayed with PP plastic
<b>Guard grille material</b>	Steel, coated with black plastic (RAL 9005)
<b>Number of blades</b>	5
<b>Airflow direction</b>	"V"
<b>Direction of rotation</b>	Counterclockwise, viewed toward rotor
<b>Degree of protection</b>	IP54
<b>Insulation class</b>	"B"
<b>Moisture (F) / Environmental (H) protection class</b>	F3-1
<b>Max. permitted ambient temp. for motor (transport/storage)</b>	80 °C
<b>Min. permitted ambient temp. for motor (transport/storage)</b>	-40 °C
<b>Installation position</b>	Shaft horizontal or rotor on bottom; rotor on top on request
<b>Condensation drainage holes</b>	On rotor side
<b>Mode</b>	S1
<b>Motor bearing</b>	Ball bearing
<b>Technical features</b>	<ul style="list-style-type: none"> <li>- Output 10 VDC, max. 1.1 mA</li> <li>- Alarm relay</li> <li>- Motor current limitation</li> <li>- Soft start</li> <li>- Control input 0-10 VDC / PWM</li> <li>- Control interface with SELV potential safely disconnected from supply</li> <li>- Thermal overload protection for electronics/motor</li> <li>- Line undervoltage detection</li> </ul>
<b>EMC immunity to interference</b>	According to EN 61000-6-2 (industrial environment)
<b>EMC circuit feedback</b>	According to EN 61000-3-2/3
<b>EMC interference emission</b>	According to EN 61000-6-3 (household environment)
<b>Touch current according to IEC 60990 (measuring circuit Fig. 4, TN system)</b>	≤ 3.5 mA
<b>Electrical hookup</b>	Via terminal box
<b>Motor protection</b>	Thermal overload protector (TOP) internally connected
<b>Protection class</b>	I (with customer connection of protective earth)
<b>Conformity with standards</b>	EN 61800-5-1; CE
<b>Approval</b>	EAC



# EC axial fan - HyBlade

sickle-shaped blades (S series)  
with guard grille for full nozzle

## Product drawing

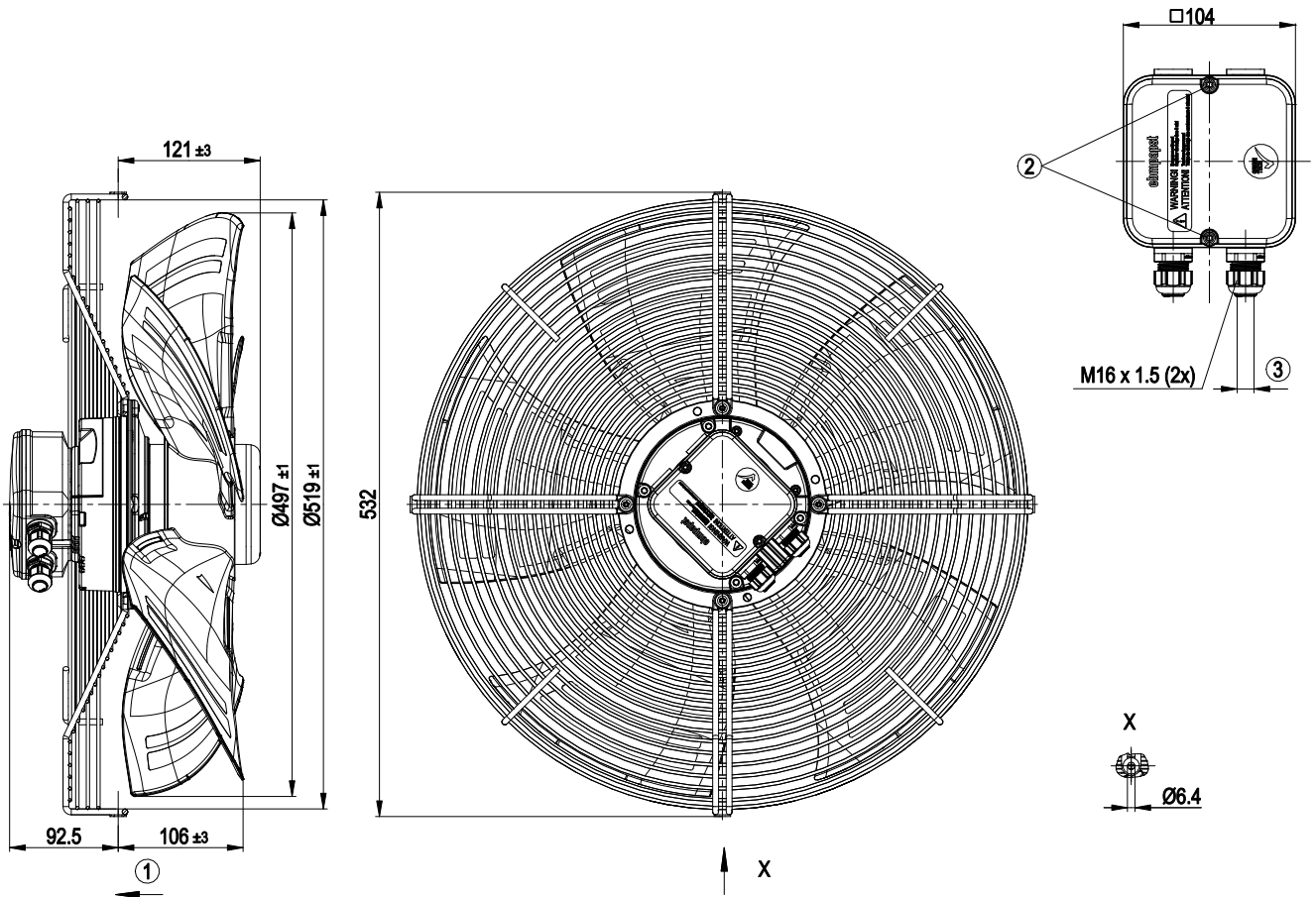

1	Airflow direction "V"
2	Tightening torque 1.5±0.2 Nm
3	Cable diameter min. 4 mm, max. 10 mm, tightening torque 2.5±0.4 Nm



# EC axial fan - HyBlade

sickle-shaped blades (S series)

with guard grille for full nozzle

## Connection diagram

Customer circuit

Application notes for various control options

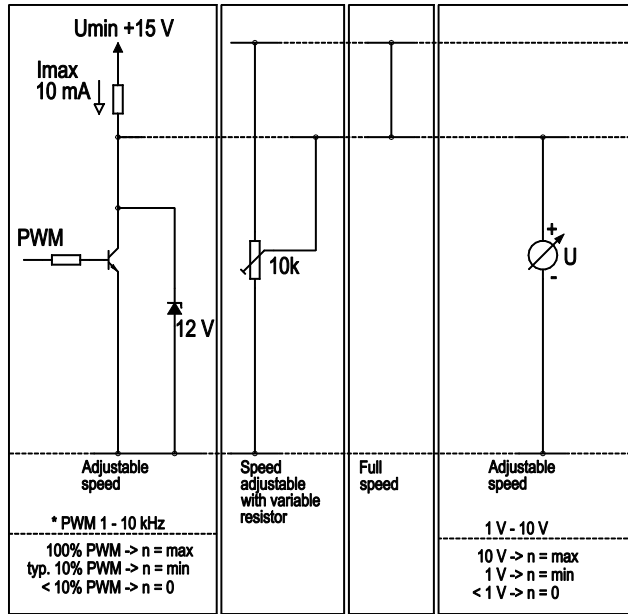

Connection

Fan / Motor

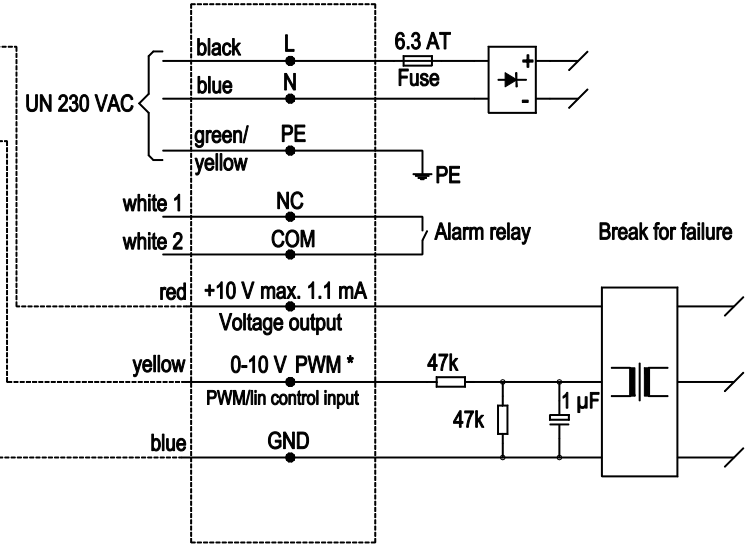

# EC axial fan - HyBlade

sickle-shaped blades (S series)

with guard grille for full nozzle

## Curves: Air performance 50 Hz

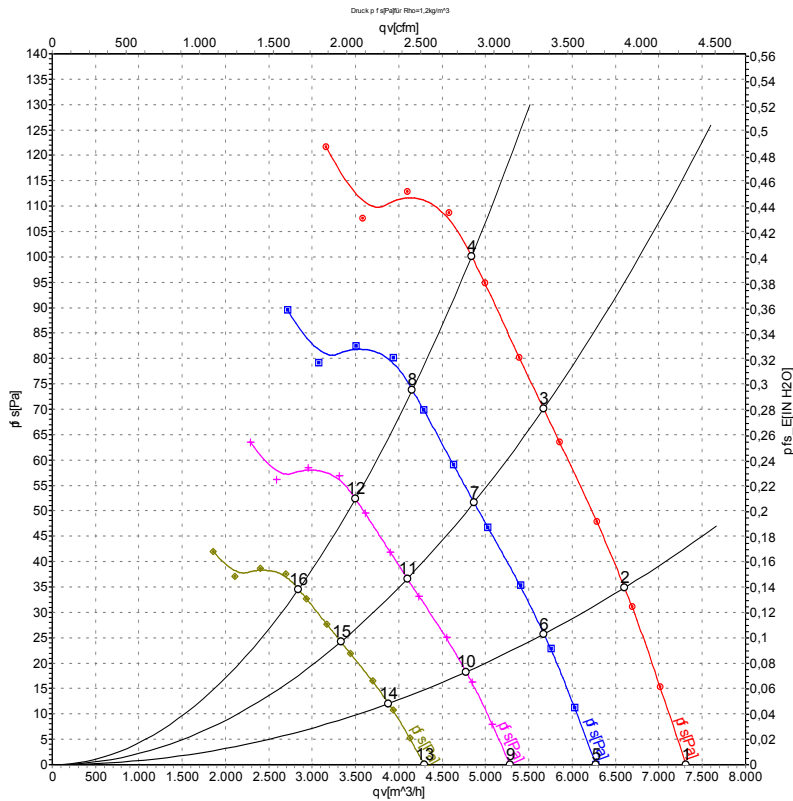

Measurement: LU-114485-1

Air performance measured according to ISO 5801 installation category A. For detailed information on the measurement setup, contact ebmpapst. Intake sound level: Sound power level according to ISO 13347 / sound pressure level measured at 1 m distance from fan axis. The values given are valid under the specified measuring conditions and may vary due to conditions of installation. For deviations from the standard configuration, the parameters have to be checked on the installed unit.

## Measured values

	U	f	n	P <sub>ed</sub>	I	LpA <sub>in</sub>	LwA <sub>in</sub>	LwA <sub>out</sub>	q <sub>v</sub>	P <sub>fs</sub>	q <sub>v</sub>	P <sub>fs</sub>
	V	Hz	min <sup>-1</sup>	W	A	dB(A)	dB(A)	dB(A)	m <sup>3</sup> /h	Pa	cfm	inH2O
1	230	50	1100	264	1.62	61	68	68	7315	0	4305	0.00
2	230	50	1100	301	1.82	60	66	66	6605	35	3885	0.14
3	230	50	1100	336	2.02	59	65	65	5670	70	3335	0.28
4	230	50	1100	360	2.20	60	66	66	4840	100	2850	0.40
5	230	50	950	166	1.02	58	65	64	6270	0	3690	0.00
6	230	50	950	191	1.15	56	63	62	5675	26	3340	0.10
7	230	50	950	213	1.27	55	62	62	4870	52	2865	0.21
8	230	50	950	228	1.37	56	63	62	4155	74	2445	0.30
9	230	50	800	99	0.61	54	61	61	5280	0	3110	0.00
10	230	50	800	114	0.69	53	59	59	4775	18	2810	0.07
11	230	50	800	127	0.76	52	58	58	4100	37	2415	0.15
12	230	50	800	136	0.82	53	59	59	3500	52	2060	0.21
13	230	50	650	53	0.33	50	56	56	4290	0	2525	0.00
14	230	50	650	61	0.37	48	55	54	3880	12	2285	0.05
15	230	50	650	68	0.41	47	54	53	3330	24	1960	0.10
16	230	50	650	73	0.44	48	55	54	2840	34	1675	0.14

U = Power supply · f = Frequency · n = Speed (rpm) · P<sub>ed</sub> = Power consumption · I = Current draw · LpA<sub>in</sub> = Sound pressure level intake side · LwA<sub>in</sub> = Sound power level intake side  
 LwA<sub>out</sub> = Sound power level outlet side · q<sub>v</sub> = Air flow · P<sub>fs</sub> = Pressure increase

