

# EC axial fan - HyBlade

sickle-shaped blades (S series)

with guard grille for full nozzle

S3G500-BA92-01 ebmpapst Datasheet

sales@fansco.com

www.fansco.com

## Nominal data

<b>Type</b>	<b>S3G500-BA92-01</b>	
<b>Motor</b>	<b>M3G112-EA</b>	
Phase		3~
Nominal voltage	VAC	400
Nominal voltage range	VAC	380 .. 480
Frequency	Hz	50/60
Method of obtaining data		ml
Status		prelim.
Speed (rpm)	min <sup>-1</sup>	1600
Power consumption	W	1000
Current draw	A	1.6
Max. back pressure	Pa	240
Max. back pressure	in. wg	0.96
Min. ambient temperature	°C	-40
Max. ambient temperature	°C	60

ml = Max. load · me = Max. efficiency · fa = Free air · cs = Customer specification · ce = Customer equipment  
Subject to change

## Data according to Commission Regulation (EU) 327/2011 (EN 17166)

		Actual	Req. 2015			
01 Overall efficiency $\eta_{es}$	%	43.4	33.7	09 Power consumption $P_{ed}$	kW	1
02 Measurement category		A		09 Air flow $q_v$	m <sup>3</sup> /h	6735
03 Efficiency category		Static		09 Pressure increase $p_{fs}$	Pa	227
04 Efficiency grade N		49.7	40	10 Speed (rpm) n	min <sup>-1</sup>	1605
05 Variable speed drive		Yes		11 Specific ratio*		1.00

Data obtained at optimum efficiency level.  
The ErP data is determined using a motor-impeller combination in a standardized measurement setup.

\* Specific ratio =  $1 + p_g / 100\,000\text{ Pa}$

LU-203812



# EC axial fan - HyBlade

sickle-shaped blades (S series)

with guard grille for full nozzle

## Technical description

Size	500 mm
Motor size	112
Rotor surface	Painted black
Terminal box material	PP plastic
Electronics housing material	Die-cast aluminum, painted black
Blade material	Press-fitted sheet steel blank, sprayed with PP plastic
Guard grille material	Steel, coated with black plastic (RAL 9005)
Number of blades	5
Airflow direction	V
Direction of rotation	Counterclockwise, viewed toward rotor
Degree of protection	IP55
Insulation class	"F"
Moisture (F) / Environmental (H) protection class	H2
Ambient temperature note	Occasional start-up at temperatures between -40°C and -25°C is permitted. For continuous operation at ambient temperatures below -25°C (such as refrigeration applications), use must be made of a fan design with special low-temperature bearings.
Max. permitted ambient temp. for motor (transport/storage)	+80 °C
Min. permitted ambient temp. for motor (transport/storage)	-40 °C
Installation position	Shaft horizontal or rotor on bottom; rotor on top on request
Condensation drainage holes	On rotor side
Mode	S1
Motor bearing	Ball bearing; (sealed)
Technical features	<ul style="list-style-type: none"> <li>- Output 10 VDC, max. 10 mA</li> <li>- Operation and alarm display</li> <li>- External 24 V input (parameter setting)</li> <li>- Alarm relay</li> <li>- Integrated PID controller</li> <li>- Motor current limitation</li> <li>- PFC, passive</li> <li>- RS-485 MODBUS-RTU</li> <li>- Soft start</li> <li>- EEPROM write cycles: 100,000 maximum</li> <li>- Control input 0-10 VDC / PWM</li> <li>- Control interface with SELV potential safely disconnected from the mains</li> <li>- Thermal overload protection for electronics/motor</li> <li>- Line undervoltage / phase failure detection</li> </ul>
Touch current according to IEC 60990 (measuring circuit Fig. 4, TN system)	<= 3.5 mA
Electrical hookup	Terminal box
Motor protection	Thermal overload protector (TOP) internally connected
Protection class	I (with customer connection of protective earth)
Conformity with standards	EN 61800-5-1; CE
Approval	CSA C22.2 No. 77 + CAN/CSA-E60730-1; EAC; UL 1004-7 + 60730-1



# EC axial fan - HyBlade

sickle-shaped blades (S series)

with guard grille for full nozzle

## Product drawing

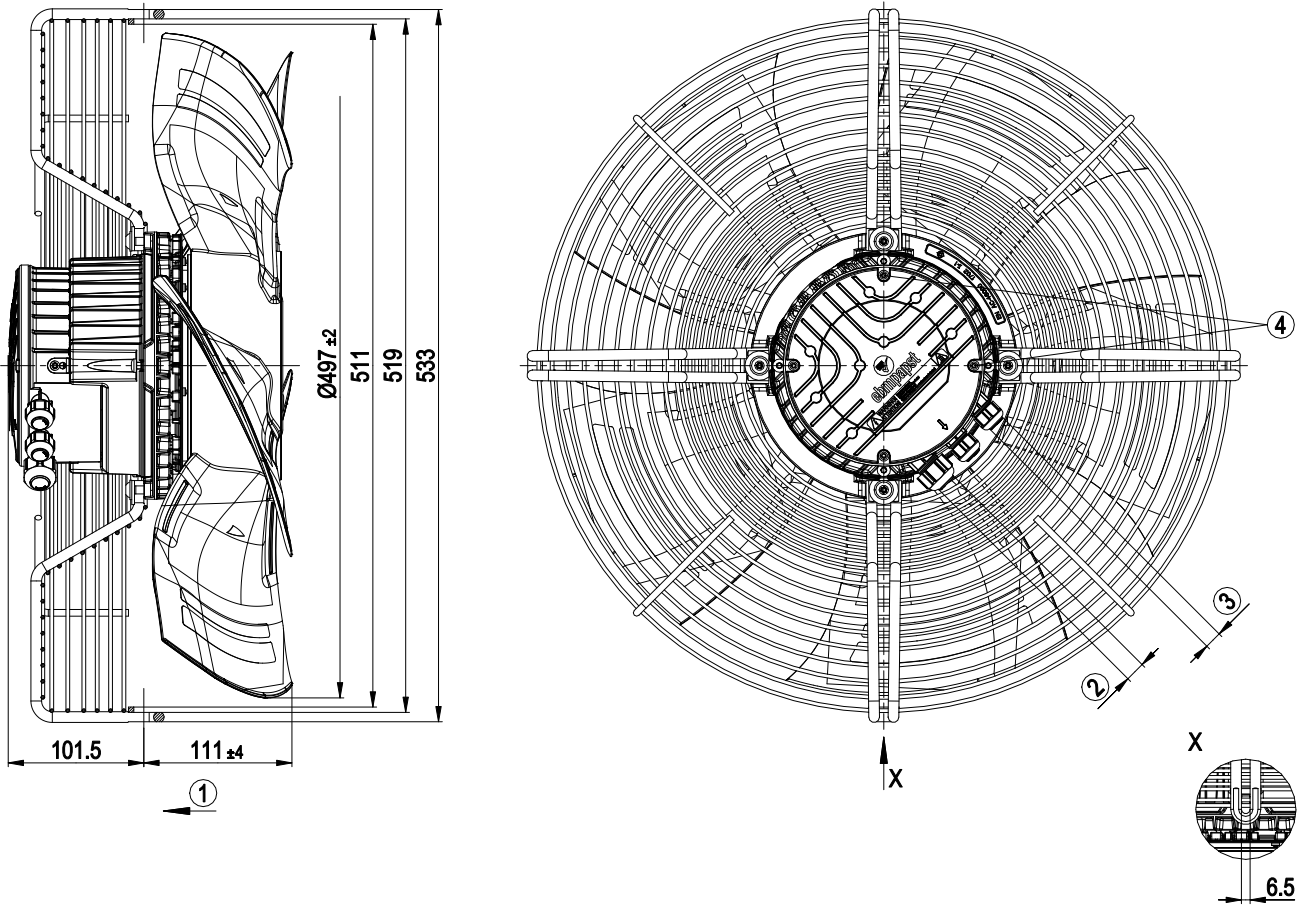

1	Airflow direction "V"
2	Cable diameter min. 8 mm, max. 12 mm, tightening torque 1.8±0.3 Nm (use must be made of seal provided) Cable diameter min. 4 mm, max. 10 mm, tightening torque 1.8±0.3 Nm
3	Cable diameter min. 6 mm, max. 10 mm, tightening torque 1.8±0.3 Nm (use must be made of seal provided) Cable diameter min. 4 mm, max. 7 mm, tightening torque 1.8±0.3 Nm
4	Tightening torque 1.5 ± 0.2 Nm



# EC axial fan - HyBlade

sickle-shaped blades (S series)

with guard grille for full nozzle

## Connection diagram

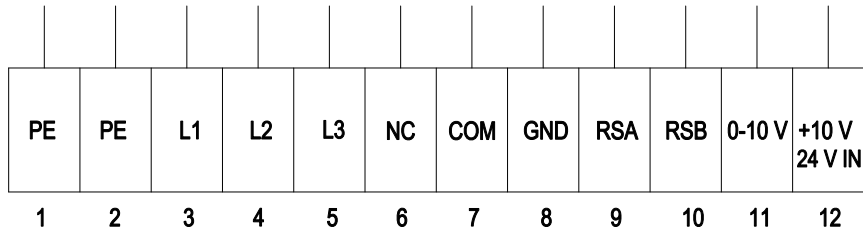

No.	Conn.	Designation	Function/assignment
1	PE	PE	Protective earth
2	PE	PE	Protective earth
3	L1	L1	Power supply
4	L2	L2	Power supply
5	L3	L3	Power supply
6	NC	NC	Status relay, floating status contact, break for failure, contact rating 250 VAC / 2 A (AC1) / min. 10 mA; reinforced insulation on supply side and basic insulation on control interface side
7	COM	COM	Status relay, floating status contact, break for failure, contact rating 250 VAC / 2 A (AC1) / min. 10 mA; reinforced insulation on supply side and basic insulation on control interface side
8	GND	GND	Reference ground for control interface, SELV
9	RSA	RSA	RS485 interface for MODBUS, RSA; SELV
10	RSB	RSB	RS485 interface for MODBUS, RSB; SELV
11	0-10 V	0-10 V	Analog input (set value) SELV, 0-10 V, Ri = 100 kΩ, adjustable curve
12	+10 V	+10 V	Fixed voltage output 10 VDC, SELV, +10 V ±3%, max. 10 mA, short-circuit-proof, power supply for external devices (e.g. pot); fixed voltage input 24 VDC for setting parameters via MODBUS without line voltage supply

# EC axial fan - HyBlade

sickle-shaped blades (S series)

with guard grille for full nozzle

## Curves: Air performance 50 Hz

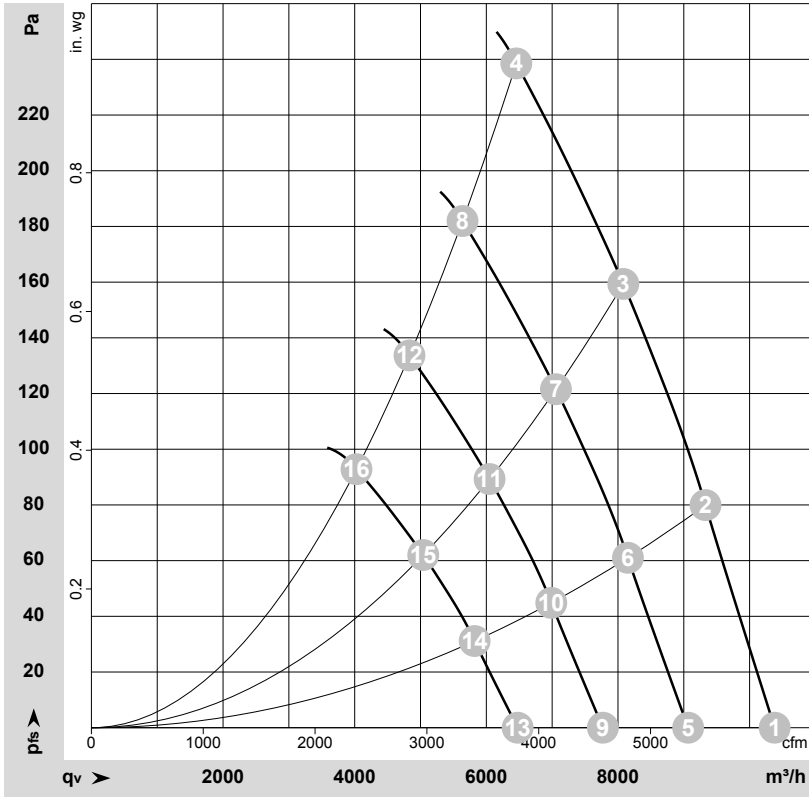

$\rho = 1.15 \text{ kg/m}^3 \pm 2 \%$

Measurement: LU-203812-1

Air performance measured according to ISO 5801 installation category A. For detailed information on the measurement setup, contact ebmpapst. Intake sound level: Sound power level according to ISO 13347 / sound pressure level measured at 1 m distance from fan axis. The values given are valid under the specified measuring conditions and may vary due to conditions of installation. For deviations from the standard configuration, the parameters have to be checked on the installed unit.

## Measured values

	Wired	U	f	n	P <sub>ed</sub>	I	LpA <sub>in</sub>	LwA <sub>in</sub>	LwA <sub>out</sub>	q <sub>v</sub>	p <sub>fs</sub>	q <sub>v</sub>	p <sub>fs</sub>
		V	Hz	min <sup>-1</sup>	W	A	dB(A)	dB(A)	dB(A)	m <sup>3</sup> /h	Pa	cfm	in. wg
1	3~	400	50	1600	745	1.17	72	79	79	10380	0	6110	0.00
2	3~	400	50	1600	852	1.33	70	77	77	9330	80	5490	0.32
3	3~	400	50	1600	941	1.46	68	75	75	8080	160	4755	0.64
4	3~	400	50	1600	1000	1.60	70	77	77	6455	240	3800	0.96
5	3~	400	50	1400	496	0.78	69	76	76	9065	0	5335	0.00
6	3~	400	50	1400	568	0.88	66	74	74	8150	61	4795	0.24
7	3~	400	50	1400	627	0.97	65	72	72	7060	122	4155	0.49
8	3~	400	50	1400	679	1.05	67	74	73	5640	182	3320	0.73
9	3~	400	50	1200	313	0.49	65	72	72	7770	0	4575	0.00
10	3~	400	50	1200	358	0.56	62	70	70	6985	45	4110	0.18
11	3~	400	50	1200	395	0.61	61	68	68	6050	89	3560	0.36
12	3~	400	50	1200	427	0.66	63	70	69	4835	134	2845	0.54
13	3~	400	50	1000	181	0.28	60	67	67	6475	0	3810	0.00
14	3~	400	50	1000	207	0.32	58	65	65	5820	31	3425	0.12
15	3~	400	50	1000	228	0.35	56	64	63	5040	62	2965	0.25
16	3~	400	50	1000	247	0.38	58	66	65	4025	93	2370	0.37

Wired = Wiring · U = Voltage · f = Frequency · n = Speed (rpm) · P<sub>ed</sub> = Power consumption · I = Current draw · LpA<sub>in</sub> = Sound pressure level intake side · LwA<sub>in</sub> = Sound power level intake side · LwA<sub>out</sub> = Sound power level outlet side · q<sub>v</sub> = Air flow · p<sub>fs</sub> = Pressure increase

