

EC axial fan - HyBlade

sickle-shaped blades (S series)

with guard grille for short nozzle



S3G500-AN33-02 ebmpapst Datasheet

sales@fansco.com

www.fansco.com

Limited partnership · Headquarters Muldingen

Amtsgericht (court of registration) Stuttgart · HRA 590344

General partner Elektrobau Muldingen GmbH · Headquarters Muldingen

Amtsgericht (court of registration) Stuttgart · HRB 590142



Nominal data

Type	S3G500-AN33-02	
Motor	M3G112-GA	
Phase		3~
Nominal voltage	VAC	400
Nominal voltage range	VAC	380 .. 480
Frequency	Hz	50/60
Method of obtaining data		ml
Speed (rpm)	min ⁻¹	1600
Power consumption	W	980
Current draw	A	1.6
Min. ambient temperature	°C	-25
Max. ambient temperature	°C	60

ml = Max. load · me = Max. efficiency · fa = Free air · cs = Customer specification · ce = Customer equipment
Subject to change

Data according to ErP Directive

		Actual	Req. 2015			
01 Overall efficiency η_{es}	%	43.5	33.7	09 Power consumption P_{ed}	kW	1
02 Measurement category		A		09 Air flow q_v	m ³ /h	6630
03 Efficiency category		Static		09 Pressure increase p_{fs}	Pa	218
04 Efficiency grade N		49.8	40	10 Speed (rpm) n	min ⁻¹	1610
05 Variable speed drive		Yes		11 Specific ratio*		1.00

Data obtained at optimum efficiency level.

The ErP data is determined using a motor-impeller combination in a standardized measurement setup.

* Specific ratio = $1 + p_{fs} / 100\,000\text{ Pa}$

LU-121588



Technical description

Weight	12.7 kg
Fan size	500 mm
Rotor surface	Painted black
Electronics housing material	Die-cast aluminum, painted black
Blade material	Press-fitted sheet steel blank, sprayed with PP plastic
Guard grille material	Steel, phosphated and coated with black plastic
Number of blades	5
Airflow direction	"A"
Direction of rotation	Clockwise, viewed toward rotor
Degree of protection	IP54
Insulation class	"B"
Moisture (F) / Environmental (H) protection class	F4-1
Max. permitted ambient temp. for motor (transport/storage)	+80 °C
Min. permitted ambient temp. for motor (transport/storage)	-40 °C
Installation position	Shaft horizontal or rotor on bottom; rotor on top on request
Condensation drainage holes	On rotor side
Mode	S1
Motor bearing	Ball bearing
Technical features	<ul style="list-style-type: none"> - Output 10 VDC, max. 10 mA - Alarm relay - Integrated PID controller - Motor current limitation - PFC, passive - Soft start - Control input 0-10 VDC / PWM - Control interface with SELV potential safely disconnected from the mains - Thermal overload protection for electronics/motor - Line undervoltage / phase failure detection
EMC immunity to interference	According to EN 61000-6-2 (industrial environment)
EMC circuit feedback	According to EN 61000-3-2/3
EMC interference emission	According to EN 61000-6-4 (industrial environment)
Touch current according to IEC 60990 (measuring circuit Fig. 4, TN system)	<= 3.5 mA
Motor protection	Thermal overload protector (TOP) internally connected
With cable	Variable
Protection class	I (with customer connection of protective earth)
Conformity with standards	EN 61800-5-1; CE
Approval	EAC

EC axial fan - HyBlade

sickle-shaped blades (S series)
with guard grille for short nozzle

Product drawing

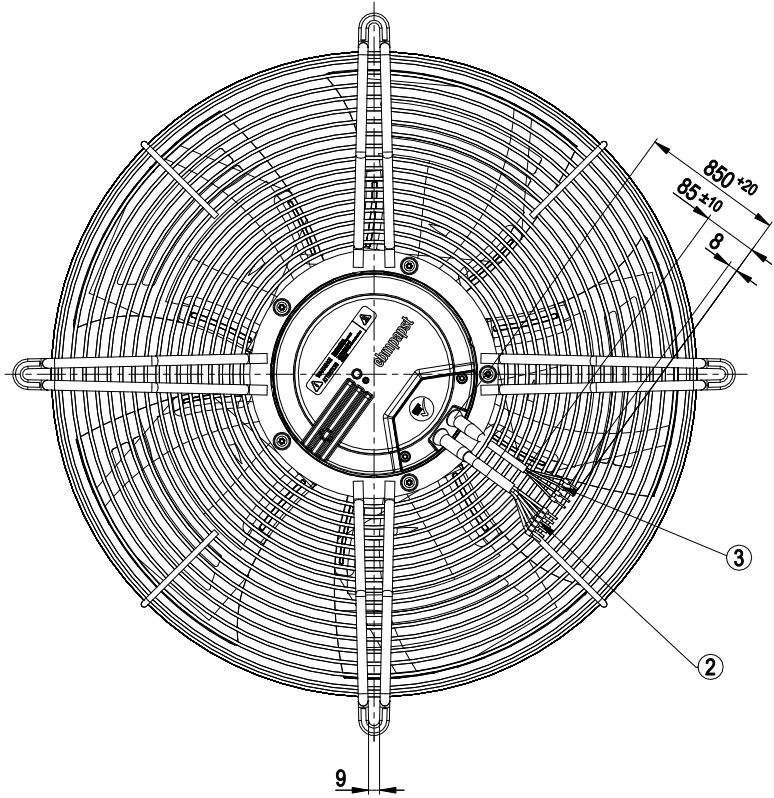
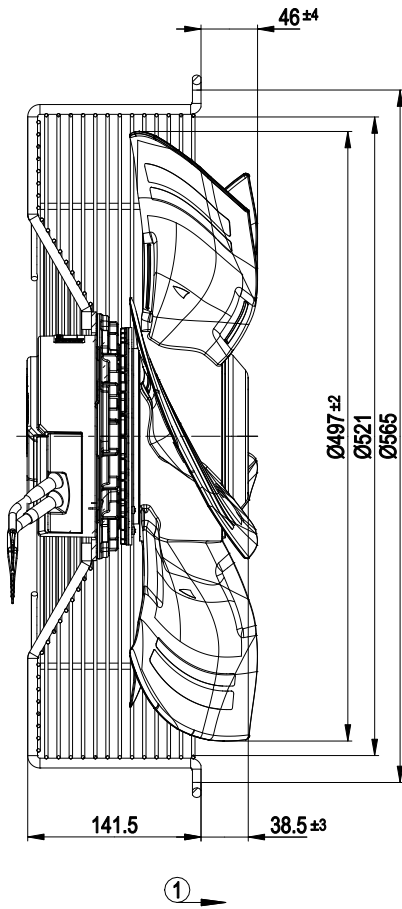

- | | |
|---|----------------------------------|
| 1 | Direction of air flow "A" |
| 2 | Cable AWG18, 6x crimped ferrules |
| 3 | Cable AWG22, 3x crimped ferrules |



EC axial fan - HyBlade

sickle-shaped blades (S series)
with guard grille for short nozzle

Connection diagram

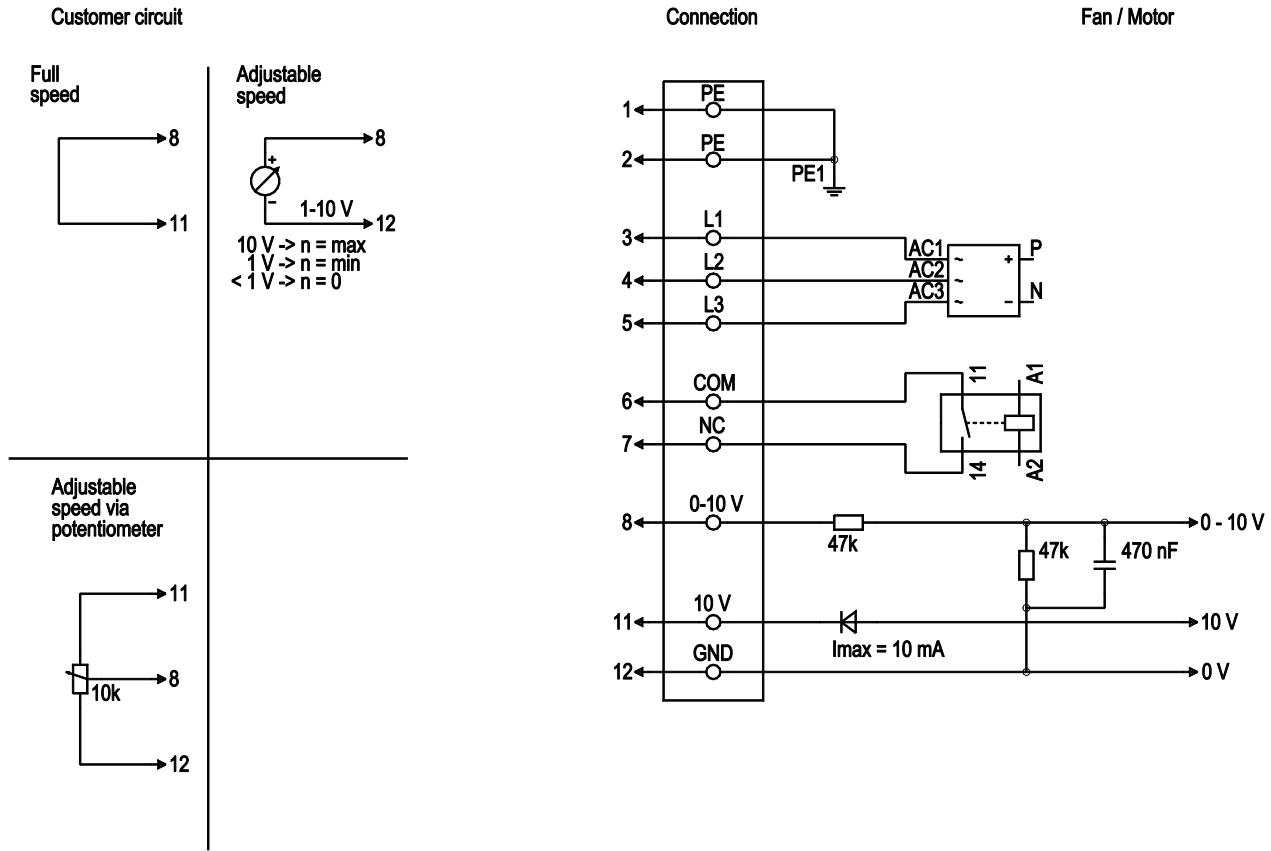

No.	Conn.	Designation	Color	Function/assignment
1	1, 2	PE	green/yellow	Protective earth
1	3, 4, 5	L1, L2, L3	black	Power supply 50 / 60 Hz
1	6	COM	white 1	Floating status contact, break for failure (2A, max. 250 VAC, min. 10 mA, AC1)
1	7	NC	white 2	Floating status contact, break for failure
2	8	0 - 10 V	yellow	Control input, set value 0-10 VDC, impedance 100 kOhm, SELV
2	11	+ 10 V	red	Voltage output 10 VDC (±3%), max. 10 mA, power supply for external devices (e.g. potentiometers), SELV
2	12	GND	blue	Reference ground for control interface, SELV



EC axial fan - HyBlade

sickle-shaped blades (S series)
with guard grille for short nozzle

Curves: Air performance 50 Hz

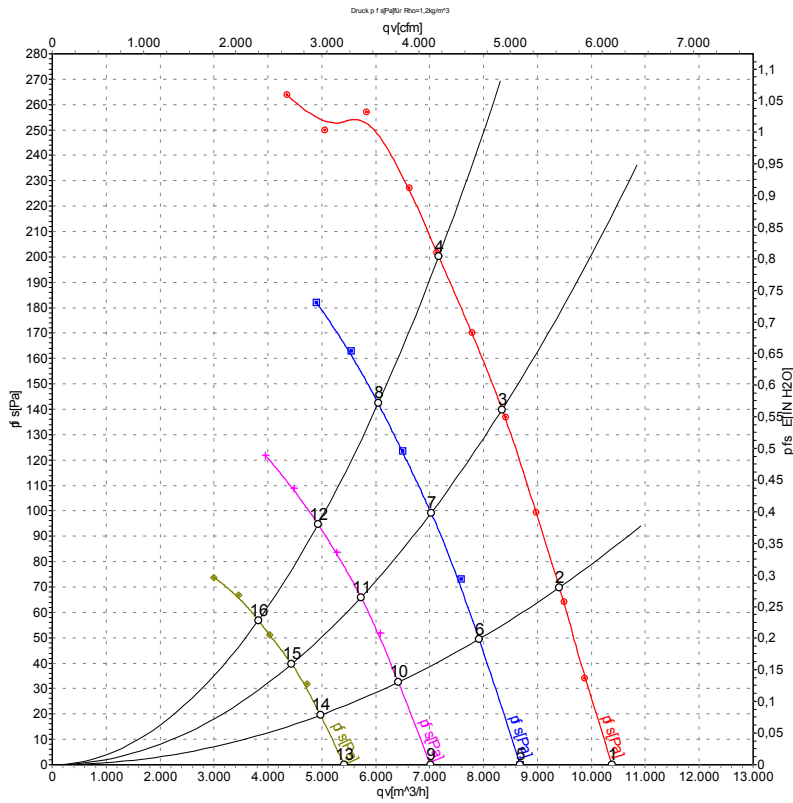

Measurement: LU-121588-1
Measurement: LU-125150-1
Measurement: LU-125151-1
Measurement: LU-125149-1

Air performance measured according to ISO 5801 installation category A. For detailed information on the measurement setup, contact ebmpapst. Intake sound level: Sound power level according to ISO 13347 / sound pressure level measured at 1 m distance from fan axis. The values given are valid under the specified measuring conditions and may vary due to conditions of installation. For deviations from the standard configuration, the parameters have to be checked on the installed unit.

Measured values

	U	f	n	P _{ed}	I	LpA _{in}	LwA _{in}	LwA _{out}	qv	P _{fs}	qv	P _{fs}
	V	Hz	min ⁻¹	W	A	dB(A)	dB(A)	dB(A)	m ³ /h	Pa	CFM	inH ₂ O
1	400	50	1600	680	1.20	72	80	80	10390	0	6115	0.00
2	400	50	1600	827	1.33	70	77	77	9405	70	5535	0.28
3	400	50	1600	907	1.41	68	75	75	8345	140	4910	0.56
4	400	50	1600	980	1.60	68	76	75	7170	200	4220	0.80
5	400	50	1350	434	0.78	69	76	76	8680	0	5110	0.00
6	400	50	1350	489	0.85	66	73	73	7915	51	4660	0.20
7	400	50	1350	538	0.91	64	71	71	7025	99	4135	0.40
8	400	50	1350	577	0.95	64	71	71	6045	142	3560	0.57
9	400	50	1100	256	0.51	64	72	71	7015	0	4130	0.00
10	400	50	1100	282	0.55	62	69	68	6420	33	3780	0.13
11	400	50	1100	308	0.60	59	67	66	5730	66	3370	0.26
12	400	50	1100	329	0.64	59	66	65	4930	95	2900	0.38
13	400	50	850	133	0.31	60	67	66	5415	0	3185	0.00
14	400	50	850	145	0.32	57	64	63	4975	20	2930	0.08
15	400	50	850	155	0.34	55	62	61	4445	40	2615	0.16
16	400	50	850	163	0.36	53	60	60	3820	57	2250	0.23

U = Power supply · f = Frequency · n = Speed (rpm) · P_{ed} = Power consumption · I = Current draw · LpA_{in} = Sound pressure level intake side · LwA_{in} = Sound power level intake side
LwA_{out} = Sound power level outlet side · qv = Air flow · P_{fs} = Pressure increase

