

S3G500-AM56-21

EC axial fan - HyBlade

sickle-shaped blades (S series)

with guard grille for short nozzle



S3G500-AM56-21 ebmpapst Datasheet

sales@fansco.com

www.fansco.com

Limited partnership · Headquarters Muldingen
Amtsgericht (court of registration) Stuttgart · HRA 590344

General partner Elektrobau Muldingen GmbH · Headquarters Muldingen
Amtsgericht (court of registration) Stuttgart · HRB 590142

Nominal data

Type	S3G500-AM56-21	
Motor	M3G112-EA	
Phase		1~
Nominal voltage	VAC	230
Nominal voltage range	VAC	200 .. 277
Frequency	Hz	50/60
Method of obtaining data		ml
Speed (rpm)	min ⁻¹	1420
Power consumption	W	750
Current draw	A	3.4
Max. back pressure	Pa	175
Max. back pressure	in. wg	0.7
Min. ambient temperature	°C	-25
Max. ambient temperature	°C	60

ml = Max. load · me = Max. efficiency · fa = Free air · cs = Customer specification · ce = Customer equipment
Subject to change

Data according to Commission Regulation (EU) 327/2011 (EN 17166)

		Actual	Req. 2015			
01 Overall efficiency η_{es}	%	39.4	32.8	09 Power consumption P_{ed}	kW	0.73
02 Measurement category		A		09 Air flow q_v	m ³ /h	5850
03 Efficiency category		Static		09 Pressure increase p_{fs}	Pa	173
04 Efficiency grade N		46.6	40	10 Speed (rpm) n	min ⁻¹	1425
05 Variable speed drive		Yes		11 Specific ratio*		1.00

Data obtained at optimum efficiency level.
The ErP data is determined using a motor-impeller combination in a standardized measurement setup.

* Specific ratio = $1 + p_{fs} / 100\,000\text{ Pa}$

LU-121382



Technical description

Weight	10.84 kg
Size	500 mm
Motor size	112
Rotor surface	Painted black
Electronics housing material	Die-cast aluminum, painted black
Blade material	Press-fitted sheet steel blank, sprayed with PP plastic
Guard grille material	Steel, coated with black plastic (RAL 9005)
Number of blades	5
Airflow direction	V
Direction of rotation	Counterclockwise, viewed toward rotor
Degree of protection	IP54
Insulation class	"B"
Moisture (F) / Environmental (H) protection class	H2
Max. permitted ambient temp. for motor (transport/storage)	+ 80 °C
Min. permitted ambient temp. for motor (transport/storage)	- 40 °C
Installation position	Shaft horizontal or rotor on bottom; rotor on top on request
Condensation drainage holes	On rotor side
Mode	S1
Motor bearing	Ball bearing
Technical features	<ul style="list-style-type: none"> - Output 10 VDC, max. 10 mA - Alarm relay - Motor current limitation - PFC, active - Soft start - Control input 0-10 VDC - Control interface with SELV potential safely disconnected from supply - Thermal overload protection for electronics/motor - Line undervoltage / phase failure detection
EMC immunity to interference	According to EN 61000-6-2 (industrial environment)
EMC circuit feedback	According to EN 61000-3-2/3
EMC interference emission	According to EN 61000-6-4 (industrial environment)
Touch current according to IEC 60990 (measuring circuit Fig. 4, TN system)	<= 3.5 mA
Motor protection	Thermal overload protector (TOP) internally connected
With cable	Variable
Protection class	I (with customer connection of protective earth)
Conformity with standards	EN 61800-5-1; CE
Approval	EAC; CCC

EC axial fan - HyBlade

sickle-shaped blades (S series)
with guard grille for short nozzle

Product drawing

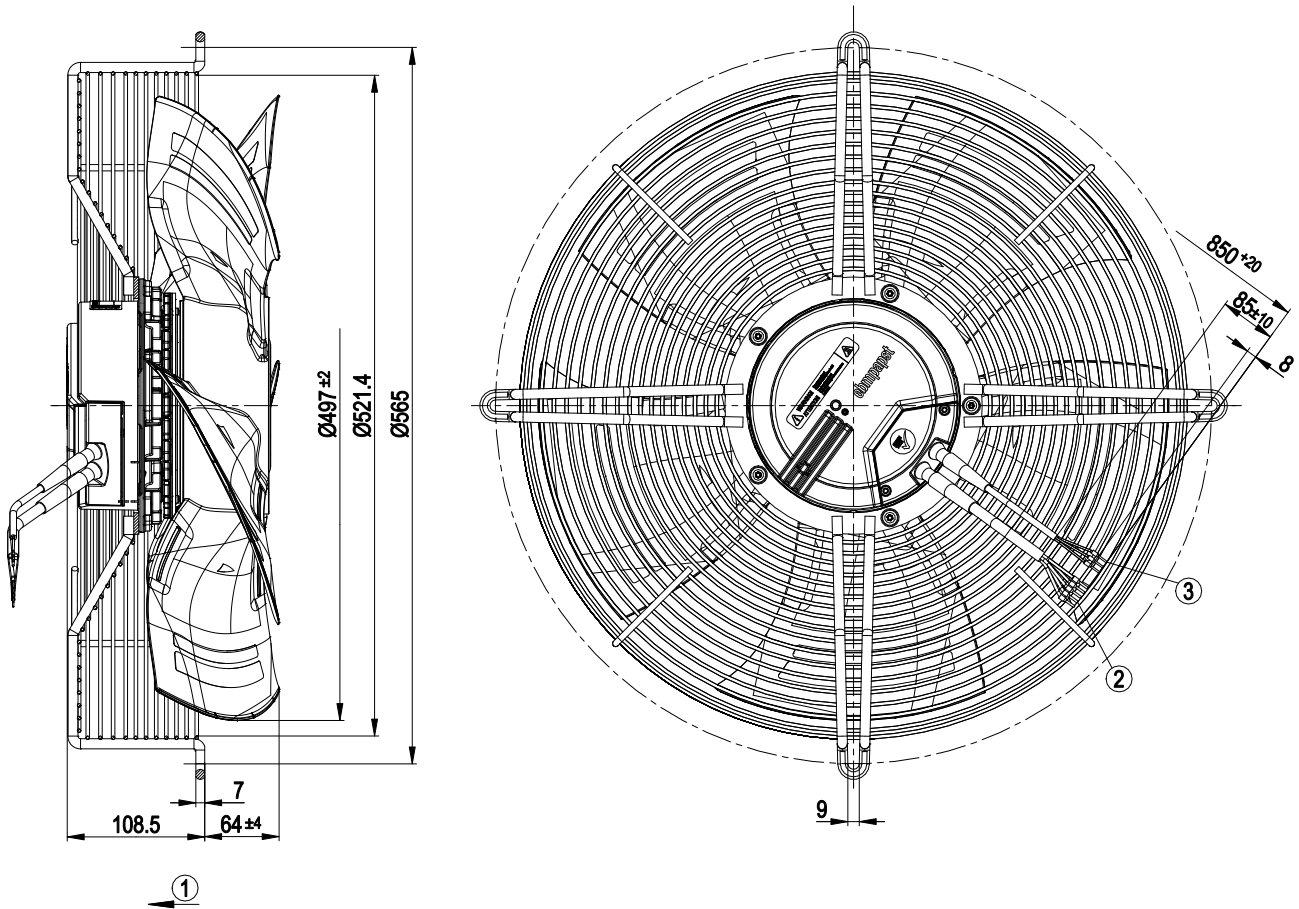

1	Direction of air flow "V"
2	Cable PVC AWG 18, 5x crimped ferrules
3	Cable PVC AWG 22, 3x crimped ferrules



EC axial fan - HyBlade

sickle-shaped blades (S series)
with guard grille for short nozzle

Connection diagram

Customer circuit

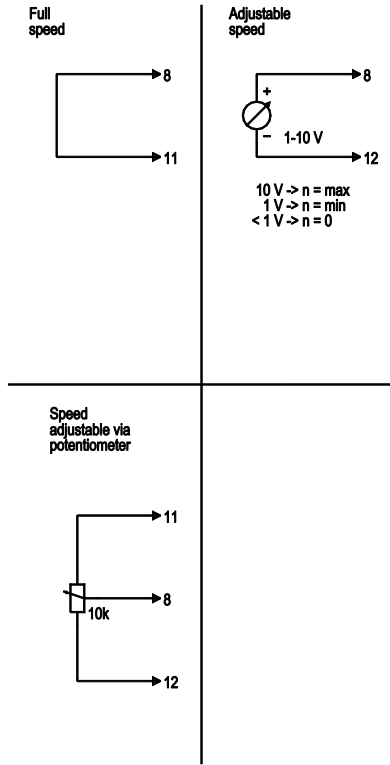

Connection

Fan / Motor

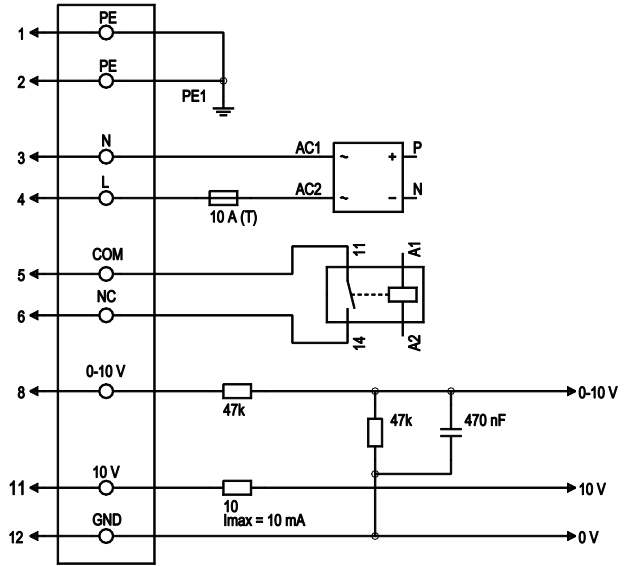

No.	Conn.	Designation	Color	Function/assignment
1	1,2	PE	green/yellow	Protective earth
1	3	N	blue	Power supply, neutral conductor, 50/60 Hz
1	4	L	black	Power supply, phase, 50/60 Hz
1	5	COM	white 1	Floating status contact, break for failure (2 A, max. 250 VAC, min. 10 mA, AC1)
1	6	NC	white 2	Floating status contact, break for failure
2	8	0-10 V	yellow	Control input, set value 0-10 VDC, impedance 100 kΩ, SELV
2	11	10 VDC	red	Voltage output 10 VDC (±3%), max. 10 mA, power supply for external devices (e.g. potentiometer), SELV
2	12	GND	blue	Reference ground for control interface, SELV



EC axial fan - HyBlade

sickle-shaped blades (S series)
with guard grille for short nozzle

Curves: Air performance 50 Hz

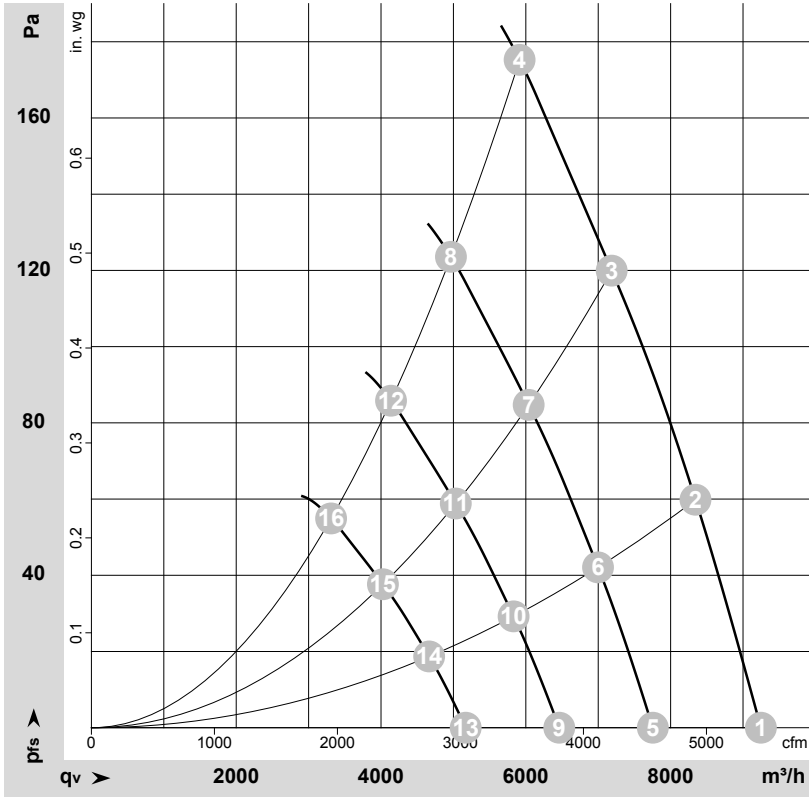

$\rho = 1.15 \text{ kg/m}^3 \pm 2 \%$

Measurement: LU-131222-1

Air performance measured according to ISO 5801 installation category A. For detailed information on the measurement setup, contact ebm-papst. Intake sound level: Sound power level according to ISO 13347 / sound pressure level measured at 1 m distance from fan axis. The values given are valid under the specified measuring conditions and may vary due to conditions of installation. For deviations from the standard configuration, the parameters have to be checked on the installed unit.

Measured values

	Wired	U	f	n	P _{ed}	I	LpA _{in}	LwA _{in}	LwA _{out}	q _v	P _{fs}	q _v	P _{fs}
		V	Hz	min ⁻¹	W	A	dB(A)	dB(A)	dB(A)	m ³ /h	Pa	cfm	in. wg
1	1~	230	50	1420	554	2.52	70	77	77	9245	0	5445	0.00
2	1~	230	50	1420	636	2.87	67	75	75	8345	60	4910	0.24
3	1~	230	50	1420	703	3.14	65	73	73	7185	120	4230	0.48
4	1~	230	50	1420	750	3.40	66	74	74	5915	175	3480	0.70
5	1~	230	50	1200	327	1.49	66	73	73	7755	0	4565	0.00
6	1~	230	50	1200	375	1.69	63	70	70	6995	42	4120	0.17
7	1~	230	50	1200	417	1.87	61	69	68	6040	85	3555	0.34
8	1~	230	50	1200	446	1.99	62	70	69	4965	124	2925	0.50
9	1~	230	50	1000	189	0.86	61	68	68	6460	0	3805	0.00
10	1~	230	50	1000	217	0.98	58	66	66	5830	29	3430	0.12
11	1~	230	50	1000	241	1.08	56	64	64	5035	59	2960	0.24
12	1~	230	50	1000	258	1.15	57	65	65	4140	86	2435	0.35
13	1~	230	50	800	97	0.44	56	63	63	5170	0	3045	0.00
14	1~	230	50	800	111	0.50	53	60	60	4665	19	2745	0.08
15	1~	230	50	800	124	0.55	51	58	58	4025	38	2370	0.15
16	1~	230	50	800	132	0.59	52	59	59	3310	55	1950	0.22

Wired = Wiring · U = Voltage · f = Frequency · n = Speed (rpm) · P_{ed} = Power consumption · I = Current draw · LpA_{in} = Sound pressure level intake side · LwA_{in} = Sound power level intake side
LwA_{out} = Sound power level outlet side · q_v = Air flow · P_{fs} = Pressure increase

