

S3G500-AF48-50 ebmpapst Datasheet

sales@fansco.com

www.fansco.com

Limited partnership · Headquarters Muldingen

Amtsgericht (court of registration) Stuttgart · HRA 590344

General partner Elektrobau Muldingen GmbH · Headquarters Muldingen

Amtsgericht (court of registration) Stuttgart · HRB 590142



Nominal data

Type	S3G500-AF48-50	
Motor	M3G084-DF	
Phase		1~
Nominal voltage	VAC	230
Nominal voltage range	VAC	200 .. 277
Frequency	Hz	50/60
Method of obtaining data		ml
Speed (rpm)	min ⁻¹	870
Power consumption	W	180
Current draw	A	1.2
Max. back pressure	Pa	70
Max. back pressure	inH ₂ O	0.28
Min. ambient temperature	°C	-25
Max. ambient temperature	°C	65

ml = Max. load · me = Max. efficiency · fa = Free air · cs = Customer specification · ce = Customer equipment
Subject to change

Data according to ErP Directive

		Actual	Req. 2015			
01 Overall efficiency η_{es}	%	39	29	09 Power consumption P_{ed}	kW	0.18
02 Measurement category		A		09 Air flow q_v	m ³ /h	3880
03 Efficiency category		Static		09 Pressure increase p_{fs}	Pa	58
04 Efficiency grade N		50	40	10 Speed (rpm) n	min ⁻¹	880
05 Variable speed drive		Yes		11 Specific ratio*		1.00

Data obtained at optimum efficiency level.

The ErP data is determined using a motor-impeller combination in a standardized measurement setup.

* Specific ratio = $1 + p_s / 100\,000\text{ Pa}$

LU-118060



Technical description

Weight	6.8 kg
Fan size	500 mm
Rotor surface	Painted black
Terminal box material	PC/ABS plastic
Electronics housing material	Die-cast aluminum
Blade material	Press-fitted sheet steel blank, sprayed with PP plastic
Guard grille material	Steel, coated with black plastic (RAL 9005)
Number of blades	5
Airflow direction	"A"
Direction of rotation	Clockwise, viewed toward rotor
Degree of protection	IP54
Insulation class	"B"
Moisture (F) / Environmental (H) protection class	F3-1
Max. permitted ambient temp. for motor (transport/storage)	+80 °C
Min. permitted ambient temp. for motor (transport/storage)	-40 °C
Installation position	Shaft horizontal or rotor on bottom
Condensation drainage holes	On rotor side
Mode	S1
Motor bearing	Ball bearing
Technical features	<ul style="list-style-type: none"> - Output 10 VDC, max. 10 mA - Tach output - Alarm relay - Motor current limitation - PFC, passive - Soft start - Control input 0-10 VDC / PWM - Control interface with SELV potential safely disconnected from the mains - Thermal overload protection for electronics/motor
Touch current according to IEC 60990 (measuring circuit Fig. 4, TN system)	<= 3.5 mA
Electrical hookup	Via terminal box
Motor protection	Thermal overload protector (TOP) internally connected
Protection class	I (with customer connection of protective earth)
Conformity with standards	EN 61800-5-1; CE

EC axial fan - HyBlade

sickle-shaped blades (S series)
with guard grille for short nozzle

Product drawing

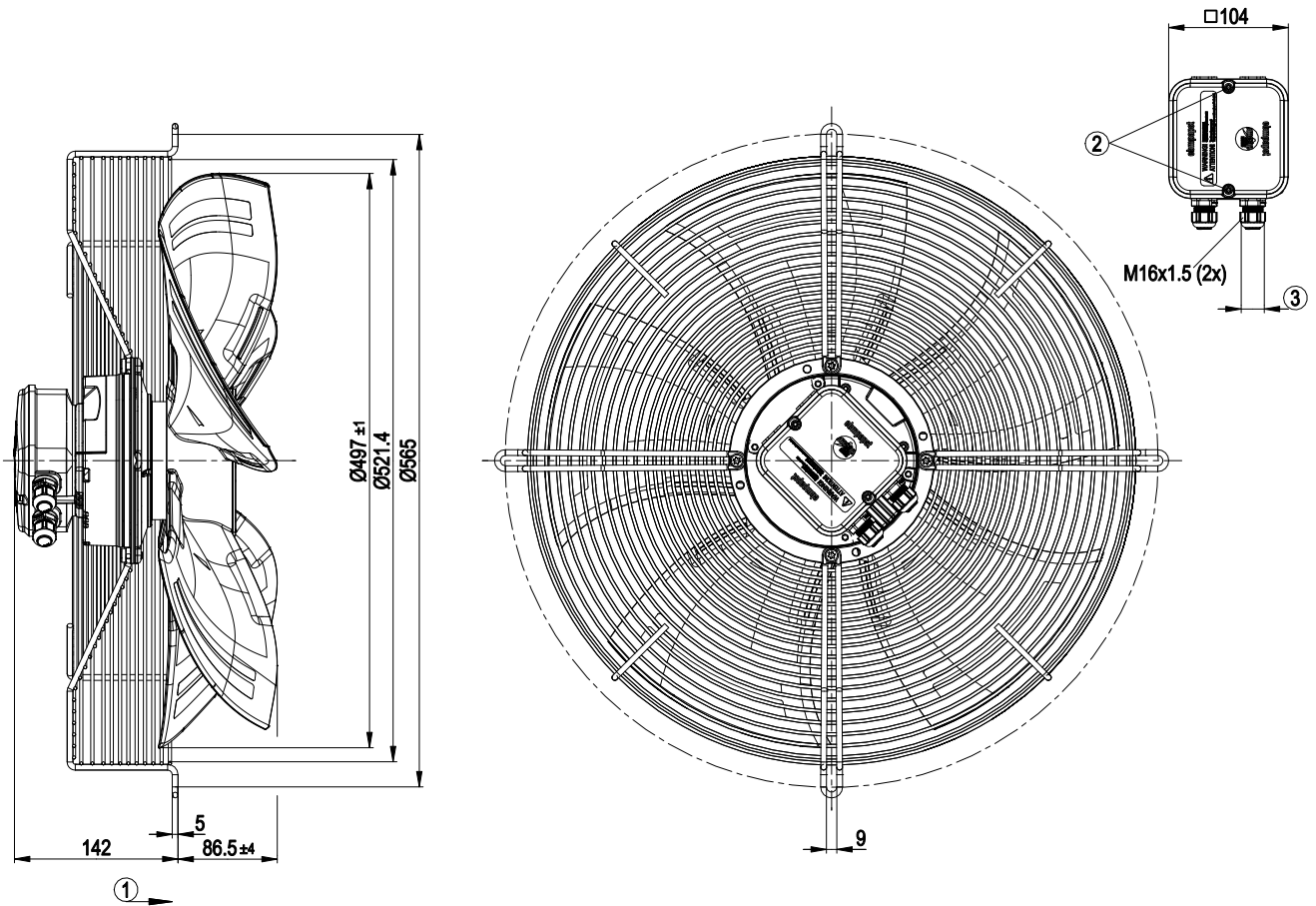

1	Direction of air flow "A"
2	Tightening torque 1.5 ± 0.2 Nm
3	Cable diameter min. 4 mm, max. 10 mm, tightening torque 2.5 ± 0.4 Nm



EC axial fan - HyBlade

sickle-shaped blades (S series)
with guard grille for short nozzle

Connection diagram

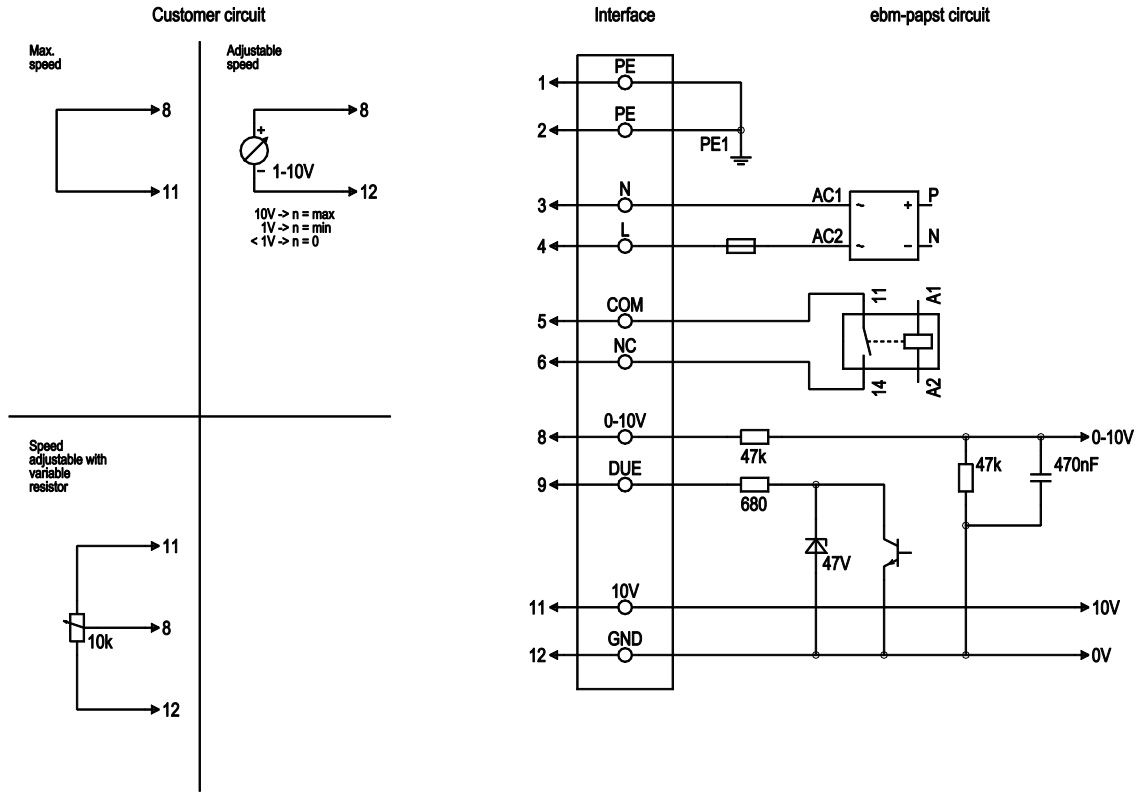

No.	Conn.	Designation	Color	Function/assignment
1	1,2	PE	green/yellow	Protective earth
1	3	N	blue	Power supply, neutral conductor, 50/60 Hz
1	4	L	black	Power supply, phase, 50/60 Hz
1	5	COM	white 1	Floating status contact, break for failure (2 A, max. 250 VAC, min. 10 mA, AC1)
1	6	NC	white 2	Floating status contact, break for failure
2	8	0 - 10 V	yellow	Control input, set value 0-10 VDC, impedance 100 kOhm, SELV
2	9	Tach	white	Speed monitoring, 1 pulse per revolution, Isink max. 5 mA
2	11	10 VDC	red	Voltage output 10 VDC (±3%), max. 10 mA, power supply for external devices (e.g. potentiometers), SELV
2	12	GND	blue	Reference ground for control interface, SELV



Curves: Air performance 50 Hz

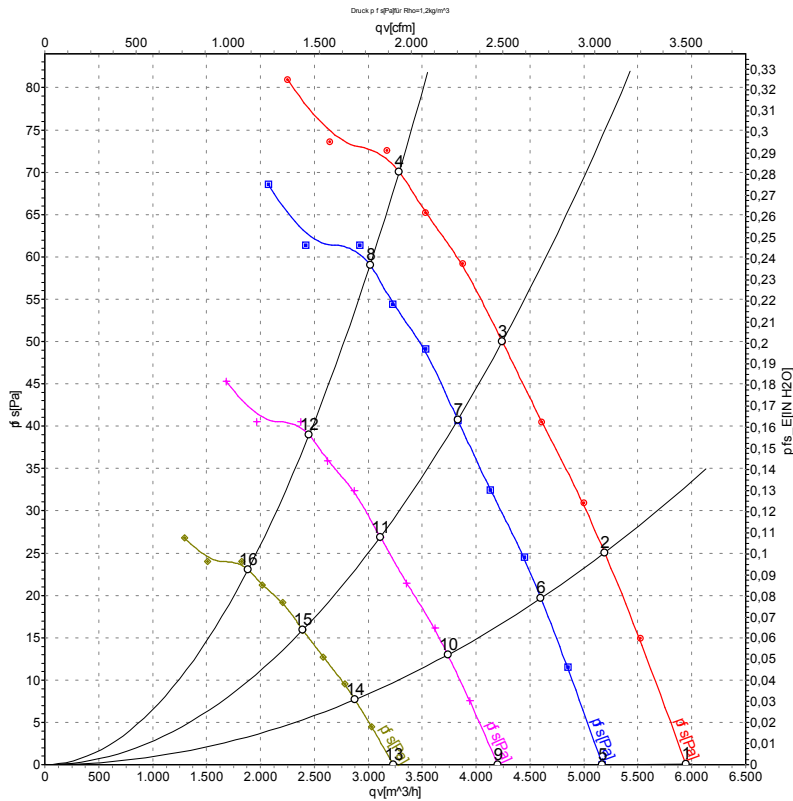

Measurement: LU-118060-1

Air performance measured according to ISO 5801 installation category A. For detailed information on the measurement setup, contact ebmpapst. Intake sound level: Sound power level according to ISO 13347 / sound pressure level measured at 1 m distance from fan axis. The values given are valid under the specified measuring conditions and may vary due to conditions of installation. For deviations from the standard configuration, the parameters have to be checked on the installed unit.

Measured values

	U	f	n	P _{ed}	I	LpA _{in}	LwA _{in}	LwA _{out}	qv	p _{fs}	qv	p _{fs}
	V	Hz	min ⁻¹	W	A	dB(A)	dB(A)	dB(A)	m ³ /h	Pa	CFM	inH2O
1	230	50	920	152	0.97	61	68	67	5945	0	3500	0.00
2	230	50	905	166	1.05	57	64	63	5190	25	3055	0.10
3	230	50	885	175	1.10	53	60	60	4240	50	2495	0.20
4	230	50	870	180	1.20	54	61	61	3285	70	1935	0.28
5	230	50	800	100	0.64	58	65	64	5170	0	3040	0.00
6	230	50	800	115	0.73	54	61	60	4600	20	2705	0.08
7	230	50	800	129	0.82	51	58	57	3830	41	2255	0.16
8	230	50	800	143	0.90	52	60	59	3015	59	1775	0.24
9	230	50	650	54	0.34	53	60	59	4200	0	2470	0.00
10	230	50	650	62	0.39	50	57	56	3740	13	2200	0.05
11	230	50	650	69	0.44	47	53	53	3110	27	1830	0.11
12	230	50	650	77	0.48	48	55	55	2450	39	1445	0.16
13	230	50	500	24	0.16	48	54	54	3230	0	1900	0.00
14	230	50	500	28	0.18	44	51	50	2875	8	1690	0.03
15	230	50	500	31	0.20	41	48	47	2395	16	1410	0.06
16	230	50	500	35	0.22	42	49	49	1885	23	1110	0.09

U = Power supply · f = Frequency · n = Speed (rpm) · P_{ed} = Power consumption · I = Current draw · LpA_{in} = Sound pressure level intake side · LwA_{in} = Sound power level intake side
LwA_{out} = Sound power level outlet side · qv = Air flow · p_{fs} = Pressure increase

