

EC axial fan

sickled blades (S series)
with guard grille for short nozzle

S3G500-AE33-01 ebmpapst Datasheet
sales@fansco.com
www.fansco.com

Nominal data

Type	S3G500-AE33-01	
Motor	M3G112-GA	
Phase		3~
Nominal voltage	VAC	400
Nominal voltage range	VAC	380 .. 480
Frequency	Hz	50/60
Type of data definition		ml
Speed	min ⁻¹	1440
Power input	W	1050
Current draw	A	1.9
Min. ambient temperature	°C	-25
Max. ambient temperature	°C	60

ml = max. load · me = max. efficiency · fa = running at free air · cs = customer specs · cu = customer unit
Subject to alterations

Data according to ErP directive

		Actual	Request 2013	Request 2015
Installation category	A			
Efficiency category	Static			
Variable speed drive	Yes			
Specific ratio*	1.00			
Overall efficiency η_{es}		37.4	29.8	33.8
Efficiency grade N		43.6	36	40
Power input P_{ed}	kW	1.03		
Air flow q_v	m ³ /h	6540		
Pressure increase p_{fs}	Pa	196		
Speed n	min ⁻¹	1455		

Data established at point of optimum efficiency



Technical features

Mass	12.4 kg
Size	500 mm
Surface of rotor	Cast in PA plastic
Material of electronics housing	Die-cast aluminium, coated in black
Material of blades	Press-fitted sheet steel blank, sprayed with PP plastic
Material of guard grille	Steel, phosphated and coated in black plastic
Number of blades	5
Direction of rotation	"V"
Type of protection	IP 54
Insulation class	"B"
Humidity class	F4-1
Max. permissible ambient motor temp. (transp./ storage)	+80 °C
Min. permissible ambient motor temp. (transp./storage)	-40 °C
Mounting position	Shaft horizontal or rotor on bottom; rotor on top on request
Condensate discharge holes	Rotor-side
Operation mode	S1
Motor bearing	Ball bearing
Technical features	<ul style="list-style-type: none"> - PFC, passive - Control input 0-10 VDC / PWM - Over-temperature protected electronics / motor - Alarm relay - Integrated PID controller - Input for sensor 0-10 V and 4-20 mA - Output for slave 0-10 V max. 3 mA - Output 20 VDC (+25 %/-10 %) max. 50 mA - Output 10 VDC (+/-3 %) max. 10 mA - RS485 ebmBUS - Motor current limit - Soft start - Line undervoltage / phase failure detection
EMC interference immunity	Acc. to EN 61000-6-2
EMC harmonics	Acc. to EN 61000-3-2/3
EMC interference emission	Acc. to EN 61000-6-3
Touch current acc. IEC 60990 (measuring network Fig. 4, TN system)	<= 3.5 mA
Electrical leads	Via terminal box
Motor protection	Thermal overload protector (TOP) wired internally
Protection class	I (if protective earth is connected by customer)

EC axial fan

sickled blades (S series)
with guard grille for short nozzle

Product drawing

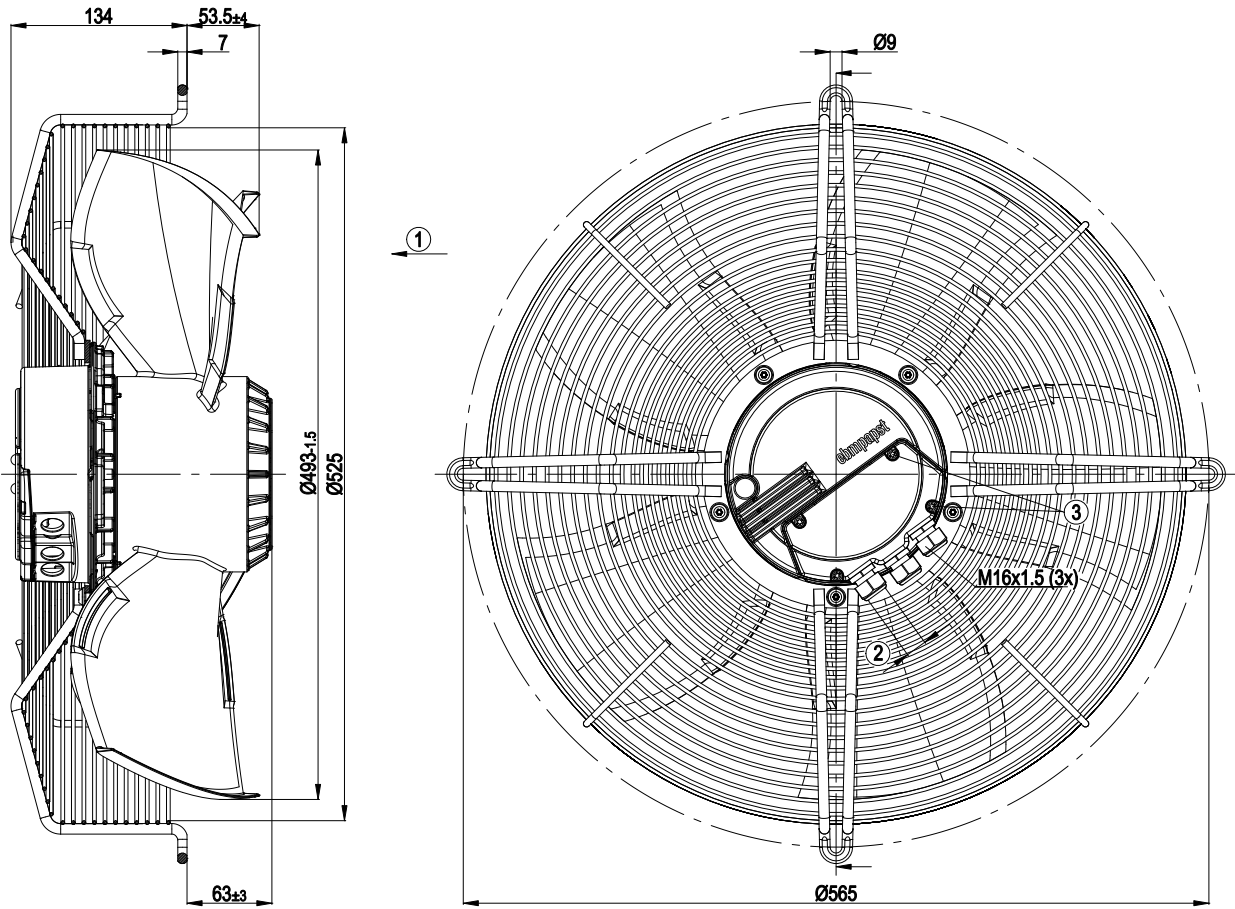

1	Direction of air flow "V"
2	Cable diameter: min. 4 mm; max. 10 mm; tightening torque: 2±0.2 Nm
3	Tightening torque 3.4 ±0.5 Nm



EC axial fan

sickled blades (S series)
with guard grille for short nozzle

Connection screen

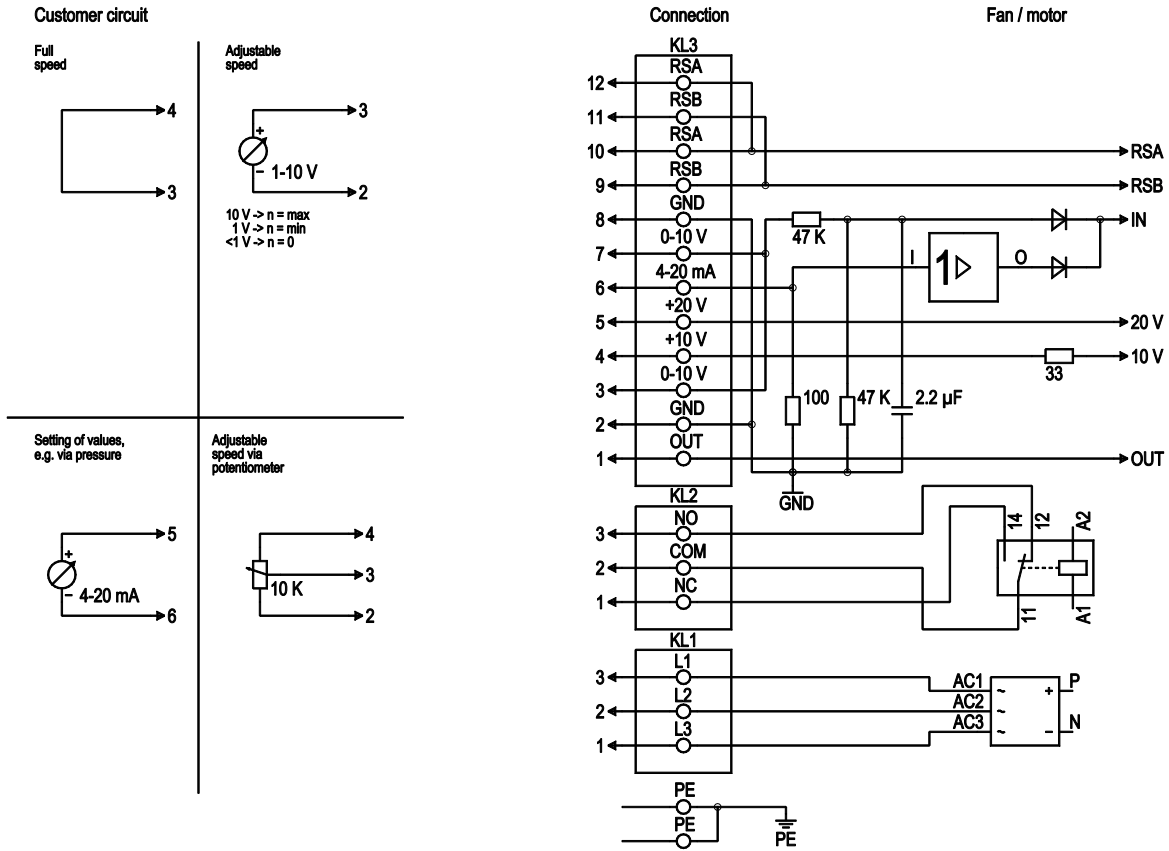

No.	Pin	Signal	Function / assignment
PE		PE	Protective earth connection
KL1	1, 2, 3	L1, L2, L3	Supply voltage, 50/60 Hz
KL2	1	NC	Floating status message contact, normally closed connection
KL2	2	COM	Floating status message contact, changeover contact, common connection (2 A, max. 250 VAC, min. 10 mA, AC1)
KL2	3	NO	Floating status message contact, normally open connection
KL3	1	OUT	Analog output, 0-10 VDC, max. 3 mA, SELV, output of the current level control coefficient: 1 V equates to 10% level control coefficient. 10 V equate to 100% level control coefficient.
KL3	2, 8	GND	Reference mass for control interface, SELV
KL3	3, 7	0-10 V	Use control / actual value input 0-10 VDC, impedance 100 kΩ only as alternative to 4-20 mA input, SELV
KL3	4	+10 V	Voltage output 10 VDC (+/-3%), max. 10 mA, supply voltage for external devices (e.g. potentiometers), SELV
KL3	5	+20 V	Voltage output 20 VDC (+25%/-10%), max. 50 mA, supply voltage for external devices (e.g. sensors), SELV
KL3	6	4-20 mA	Use control / actual value input 4-20 mA, impedance 100 Ω, only as alternative to 0-10 V input, SELV
KL3	9, 11	RSB	RS485 interface for ebmBus, RSB, SELV
KL3	10, 12	RSA	RS485 interface for ebmBus, RSA, SELV



EC axial fan

sickled blades (S series)
with guard grille for short nozzle

Charts: Air flow 50 Hz

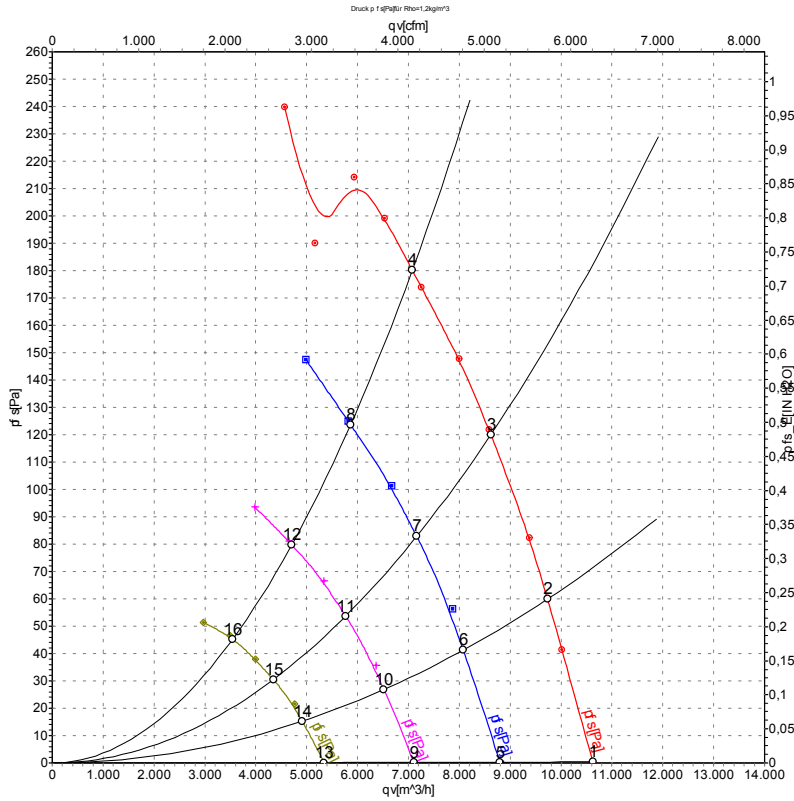

Measurement: LU-102191
Measurement: LU-120643
Measurement: LU-120644
Measurement: LU-120645

Air performance measured as per ISO 5801 Installation category A. For detailed information on the measuring set-up, please contact ebmpapst. Suction-side noise levels: LwA measured as per ISO 13347 / LpA measured with 1m distance to fan axis. The values given are valid under the measuring conditions mentioned above and may vary according to the actual installation situation. With any deviation from the standard set-up, the specific values have to be checked and reviewed with the unit installed.

Measured values

	U	f	n	P _{ed}	I	LpA _{in}	LwA _{in}	qv	ps
	V	Hz	min ⁻¹	W	A	dB(A)	dB(A)	m ³ /h	Pa
1	400	50	1440	918	1.48	72	77	10630	0
2	400	50	1440	979	1.56	73	79	9735	60
3	400	50	1440	1030	1.64	74	80	8620	120
4	400	50	1440	1050	1.90	75	82	7075	180
5	400	50	1195	499	0.92	67	73	8790	0
6	400	50	1195	539	0.97	68	74	8080	44
7	400	50	1195	562	1.01	69	75	7165	83
8	400	50	1195	567	1.02	70	76	5865	124
9	400	50	960	267	0.54	61	68	7105	0
10	400	50	960	286	0.57	61	69	6515	29
11	400	50	960	303	0.61	62	70	5765	54
12	400	50	960	312	0.62	63	71	4710	80
13	400	50	720	125	0.30	52	60	5345	0
14	400	50	720	133	0.31	53	61	4910	16
15	400	50	720	140	0.32	53	61	4345	30
16	400	50	720	141	0.32	54	62	3545	46

U = Supply voltage · f = Frequency · n = Speed · P_{ed} = Power input · I = Current draw · LpA_{in} = Sound pressure level inlet side · LwA_{in} = Sound power level inlet side · qv = Air flow
ps = Pressure increase

