

S3G500-AD02-A8 ebmpapst Datasheet

sales@fansco.com

www.fansco.com

Limited partnership · Headquarters Muldingen

Amtsgericht (court of registration) Stuttgart · HRA 590344

General partner Elektrobau Muldingen GmbH · Headquarters Muldingen

Amtsgericht (court of registration) Stuttgart · HRB 590142



Nominal data

Type	S3G500-AD02-A8	
Motor	M3G084-GF	
Phase		1~
Nominal voltage	VAC	230
Nominal voltage range	VAC	200 .. 277
Frequency	Hz	50/60
Method of obtaining data		ml
Speed (rpm)	min ⁻¹	1100
Power consumption	W	380
Current draw	A	1.7
Max. back pressure	Pa	110
Max. back pressure	inH ₂ O	0.44
Min. ambient temperature	°C	-25
Max. ambient temperature	°C	55

ml = Max. load · me = Max. efficiency · fa = Free air · cs = Customer specification · ce = Customer equipment
Subject to change

Data according to ErP Directive

		Actual	Req. 2015			
01 Overall efficiency η_{es}	%	40.9	30.8	09 Power consumption P_{ed}	kW	0.35
02 Measurement category		A		09 Air flow q_v	m ³ /h	4535
03 Efficiency category		Static		09 Pressure increase p_{fs}	Pa	105
04 Efficiency grade N		50.1	40	10 Speed (rpm) n	min ⁻¹	1110
05 Variable speed drive		Yes		11 Specific ratio*		1.00

Data obtained at optimum efficiency level.

The ErP data is determined using a motor-impeller combination in a standardized measurement setup.

* Specific ratio = $1 + p_s / 100\,000\text{ Pa}$

LU-133031



EC axial fan - HyBlade

sickle-shaped blades (S series)

with guard grille for short nozzle

Technical description

Weight	8.3 kg
Fan size	500 mm
Rotor surface	Painted black
Terminal box material	PC/ABS plastic
Electronics housing material	Die-cast aluminum
Blade material	Press-fitted sheet steel blank, sprayed with PP plastic
Guard grille material	Steel, coated with black plastic (RAL 9005)
Number of blades	5
Airflow direction	"V"
Direction of rotation	Counterclockwise, viewed toward rotor
Degree of protection	IP54
Insulation class	"B"
Moisture (F) / Environmental (H) protection class	F3-1
Max. permitted ambient temp. for motor (transport/storage)	+80 °C
Min. permitted ambient temp. for motor (transport/storage)	-40 °C
Installation position	Shaft horizontal or rotor on bottom; rotor on top on request
Condensation drainage holes	On rotor side
Mode	S1
Motor bearing	Ball bearing
Technical features	<ul style="list-style-type: none"> - Output 10 VDC, max. 10 mA - Alarm relay - Motor current limitation - PFC, active - Soft start - Control input 0-10 VDC / PWM - Control interface with SELV potential safely disconnected from the mains - Thermal overload protection for electronics/motor - Line undervoltage / phase failure detection
EMC immunity to interference	According to EN 61000-6-2 (industrial environment)
EMC circuit feedback	According to EN 61000-3-2/3
EMC interference emission	According to EN 61000-6-3 (household environment)
Touch current according to IEC 60990 (measuring circuit Fig. 4, TN system)	<= 3.5 mA
Electrical hookup	Via terminal box
Motor protection	Thermal overload protector (TOP) internally connected
Protection class	I (with customer connection of protective earth)
Conformity with standards	EN 61800-5-1; CE



EC axial fan - HyBlade

sickle-shaped blades (S series)
with guard grille for short nozzle

Product drawing

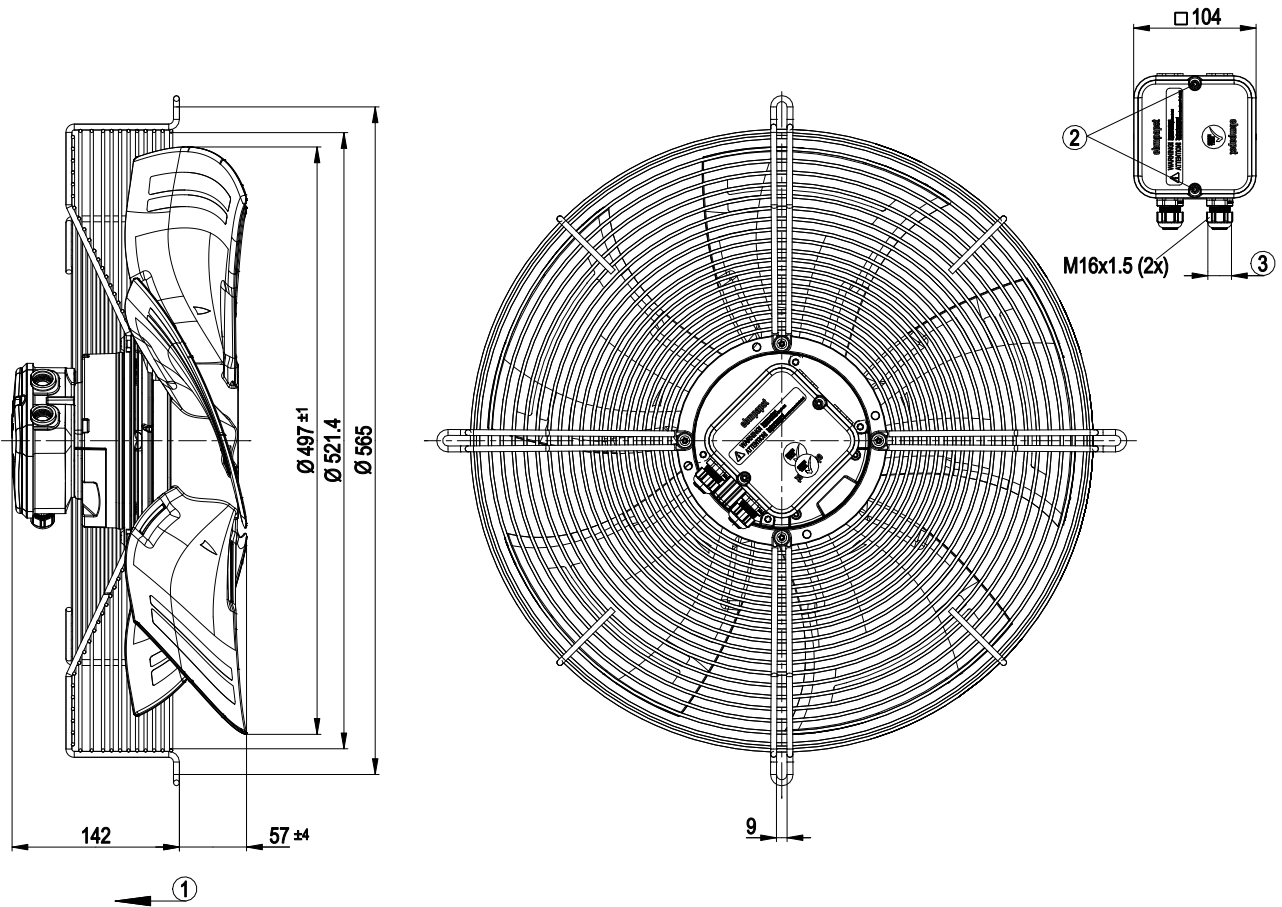

1	Direction of air flow "V"
2	Tightening torque 1.5 ± 0.2 Nm
3	Cable diameter min. 4 mm, max. 10 mm, tightening torque 2.5 ± 0.4 Nm



EC axial fan - HyBlade

sickle-shaped blades (S series)
with guard grille for short nozzle

Connection diagram

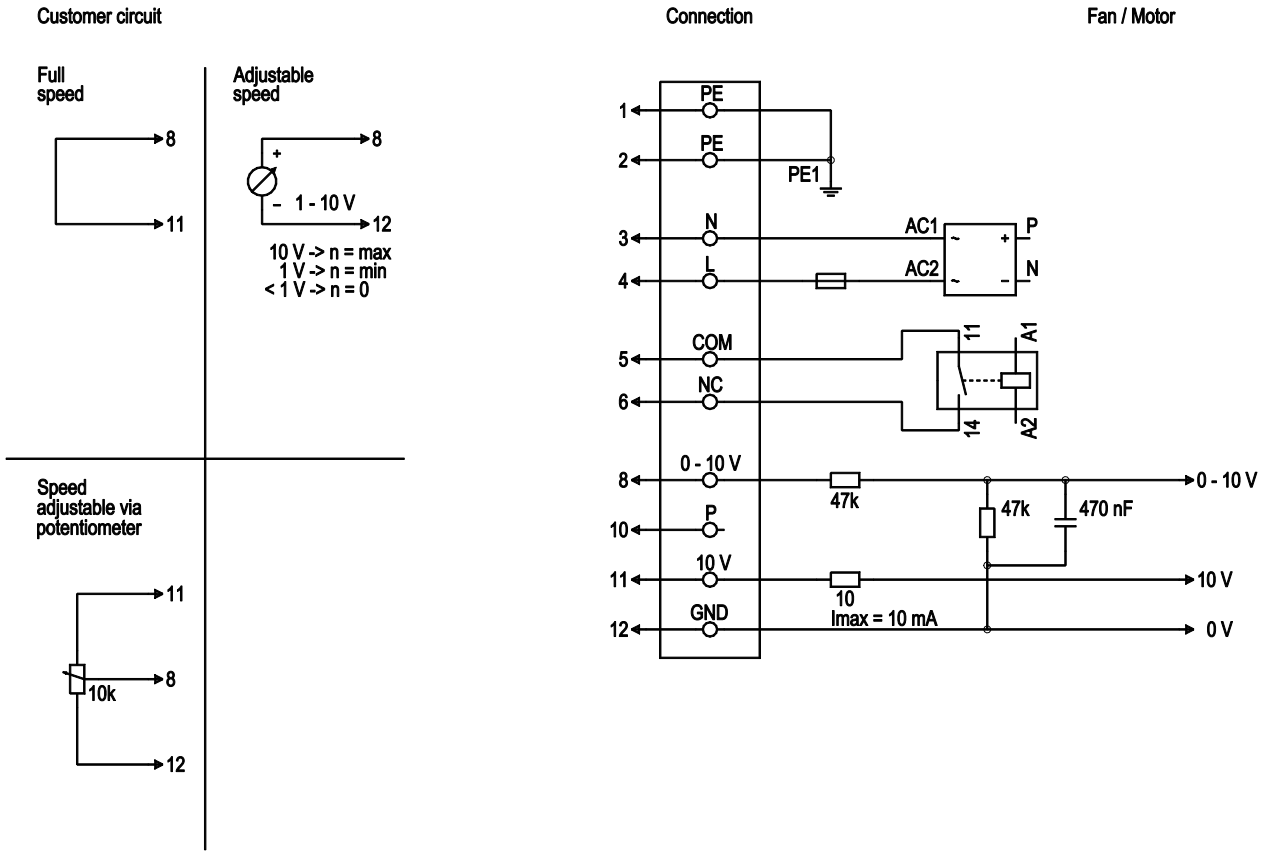

No.	Conn.	Designation	Color	Function/assignment
1	1, 2	PE	green/yellow	Protective earth
1	3	N	blue	Power supply, neutral conductor, see nameplate for voltage range, 50/60 Hz
1	4	L	black	Power supply, phase, see nameplate for voltage range, 50/60 Hz
1	5	COM	white 1	Floating status contact, break for failure (2 A, max. 250 VAC, min. 10 mA)
1	6	NC	white 2	Floating status contact, break for failure
2	8	0 - 10 V	yellow	Control input, set value 0-10 VDC, impedance 100 kOhm, SELV
2	10	P	orange	not used
2	11	10 VDC	red	Voltage output 10 VDC ($\pm 3\%$), max. 10 mA, power supply for external devices (e.g. potentiometers), SELV
2	12	GND	blue	Reference ground for control interface, SELV



EC axial fan - HyBlade

sickle-shaped blades (S series)
with guard grille for short nozzle

Curves: Air performance 50 Hz

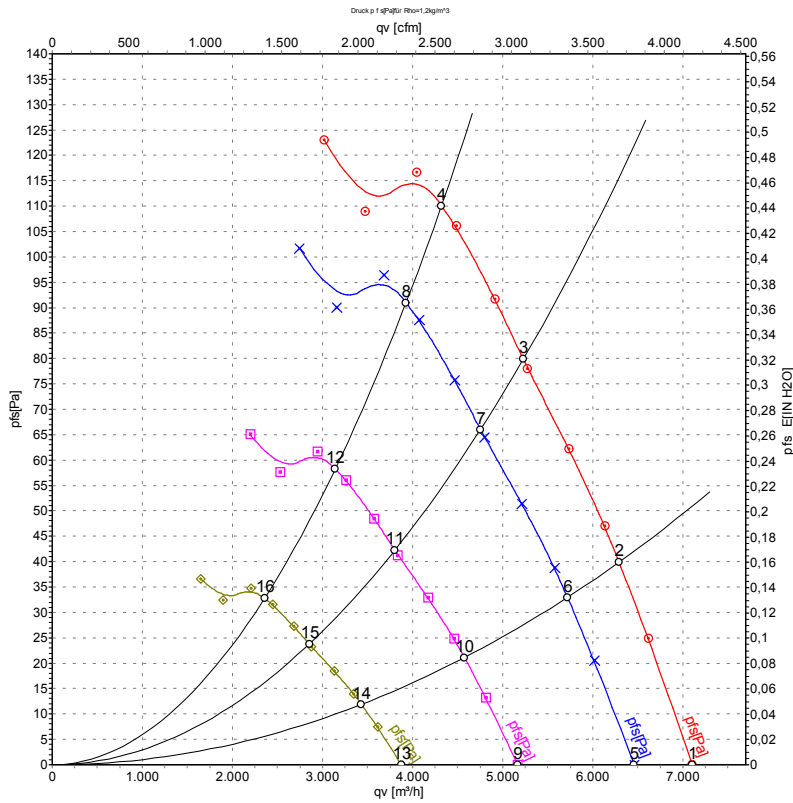

Air performance measured according to ISO 5801 installation category A. For detailed information on the measurement setup, contact ebm-papst. Intake sound level: Sound power level according to ISO 13347 / sound pressure level measured at 1 m distance from fan axis. The values given are valid under the specified measuring conditions and may vary due to conditions of installation. For deviations from the standard configuration, the parameters have to be checked on the installed unit.

Measured values

	U	f	n	P _{ed}	I	LpA _{in}	LwA _{in}	LwA _{out}	qv	P _{fs}	qv	P _{fs}
	V	Hz	min ⁻¹	W	A	dB(A)	dB(A)	dB(A)	m ³ /h	Pa	CFM	inH ₂ O
1	230	50	1100	250	1.11	63	70	69	7110	0	4185	0.00
2	230	50	1100	291	1.28	60	66	65	6295	40	3705	0.16
3	230	50	1100	326	1.43	59	65	64	5230	80	3080	0.32
4	230	50	1100	350	1.60	62	69	68	4320	110	2545	0.44
5	230	50	1000	188	0.83	61	68	67	6460	0	3805	0.00
6	230	50	1000	219	0.96	58	64	63	5720	33	3365	0.13
7	230	50	1000	245	1.08	57	63	62	4755	66	2800	0.26
8	230	50	1000	262	1.15	60	66	66	3930	91	2310	0.37
9	230	50	800	96	0.43	56	63	62	5170	0	3040	0.00
10	230	50	800	112	0.49	53	59	59	4575	21	2695	0.08
11	230	50	800	125	0.55	52	58	57	3805	42	2240	0.17
12	230	50	800	134	0.59	55	62	61	3145	58	1850	0.23
13	230	50	600	41	0.18	50	57	56	3875	0	2280	0.00
14	230	50	600	47	0.21	47	53	52	3430	12	2020	0.05
15	230	50	600	53	0.23	45	52	51	2855	24	1680	0.10
16	230	50	600	57	0.25	49	55	55	2355	33	1385	0.13

U = Power supply · f = Frequency · n = Speed (rpm) · P_{ed} = Power consumption · I = Current draw · LpA_{in} = Sound pressure level intake side · LwA_{in} = Sound power level intake side
LwA_{out} = Sound power level outlet side · qv = Air flow · P_{fs} = Pressure increase

