

EC axial fan

sickled blades (S series)
with guard grille for full nozzle

S3G350-BA58-02 ebmpapst Datasheet
sales@fansco.com
www.fansco.com

Limited partnership · Headquarters Muldingen
County court Stuttgart · HRA 590344

General partner Elektrobau Muldingen GmbH · Headquarters Muldingen
County court Stuttgart · HRB 590142



Nominal data

Type	S3G350-BA58-02	
Motor	M3G074-CF	
Phase		1~
Nominal voltage	VAC	230
Nominal voltage range	VAC	200 .. 277
Frequency	Hz	50/60
Type of data definition		fa
Speed	min ⁻¹	1540
Power input	W	150
Current draw	A	1.2
Min. ambient temperature	°C	-25
Max. ambient temperature	°C	60

ml = max. load · me = max. efficiency · fa = running at free air · cs = customer specs · cu = customer unit
Subject to alterations

Data according to ErP directive

Installation category	A
Efficiency category	Static
Variable speed drive	Yes
Specific ratio*	1.00

* Specific ratio = $1 + p_{fs} / 100\,000 \text{ Pa}$

		Actual	Request 2013	Request 2015
Overall efficiency η_{es}		41.6	24.6	28.6
Efficiency grade N		53	36	40
Power input P_{ed}	kW	0.16		
Air flow q_v	m ³ /h	2195		
Pressure increase p_{fs}	Pa	100		
Speed n	min ⁻¹	1450		

Data established at point of optimum efficiency



EC axial fan

sickled blades (S series)
with guard grille for full nozzle

Technical features

Mass	4.1 kg
Size	350 mm
Surface of rotor	Coated in black
Material of electronics housing	Die-cast aluminium
Material of impeller	Sheet steel, coated in black
Material of guard grille	Steel, phosphated and coated in black plastic
Number of blades	5
Direction of air flow	"A"
Direction of rotation	Clockwise, seen on rotor
Type of protection	IP 44; Depending on installation and position as per EN 60034-5
Insulation class	"B"
Humidity class	F3-1
Max. permissible ambient motor temp. (transp./ storage)	+ 80 °C
Min. permissible ambient motor temp. (transp./storage)	- 40 °C
Mounting position	Shaft horizontal or rotor on bottom; rotor on top on request
Condensate discharge holes	Rotor-side
Operation mode	S1
Motor bearing	Ball bearing
Technical features	<ul style="list-style-type: none"> - Output 10 VDC, max. 1.1 mA - Tach output - Motor current limit - Soft start - Control input 0-10 VDC / PWM - Over-temperature protected electronics / motor
EMC interference immunity	Acc. to EN 61000-6-2 (industrial environment)
EMC harmonics	Acc. to EN 61000-3-2/3
EMC interference emission	Acc. to EN 61000-6-3 (household environment)
Touch current acc. IEC 60990 (measuring network Fig. 4, TN system)	<= 3.5 mA
Motor protection	Thermal overload protector (TOP) wired internally
Cable exit	Variable
Protection class	I (if protective earth is connected by customer)
Product conforming to standard	EN 60335-1; CE
Approval	CSA; UL



EC axial fan

sickled blades (S series)

with guard grille for full nozzle

Product drawing

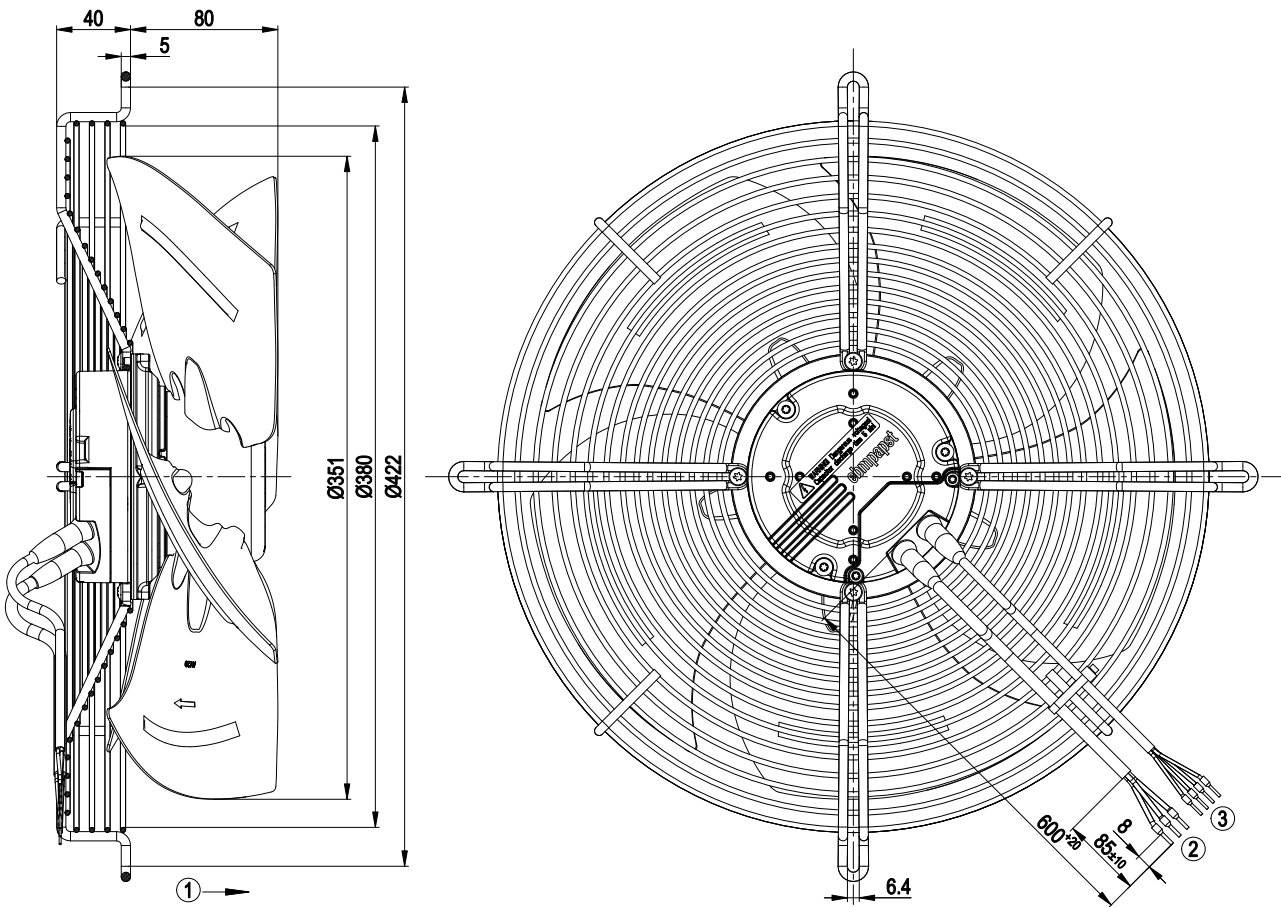

1	Direction of air flow "A"
2	Connection line PVC 3X AWG18, 3x brass lead tips crimped
3	Connection line PVC 4X AWG22, 4x brass lead tips crimped



EC axial fan

sickled blades (S series)
with guard grille for full nozzle

Connection screen

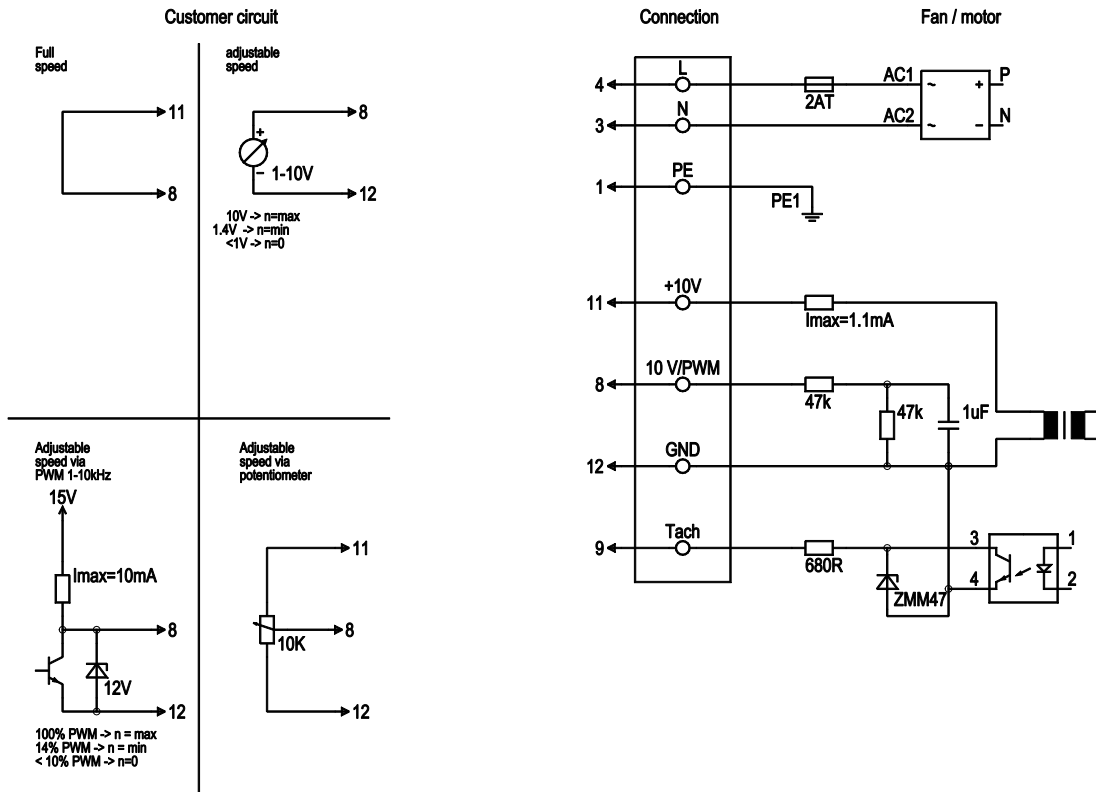

Line	No.	Signal	Colour	Function / assignment
	4	L	black	Power supply 230 VAC, 50-60 Hz, see type plate for voltage range
	3	N	blue	Neutral conductor
	1	PE	green/yellow	Protective earth
	8	0-10 V PWM	yellow	Control input 0 - 10 V or PWM, electrically isolated
	9	Tach	white	Tach output: open collector, 1 pulse per revolution, electrically isolated
	11	10V / max 1.1 mA	red	Voltage output 10 V / max. 1.1 mA, electrically isolated
	12	GND	blue	GND - Connection for control interface



EC axial fan

sickled blades (S series)
with guard grille for full nozzle

Charts: Air flow 50 Hz

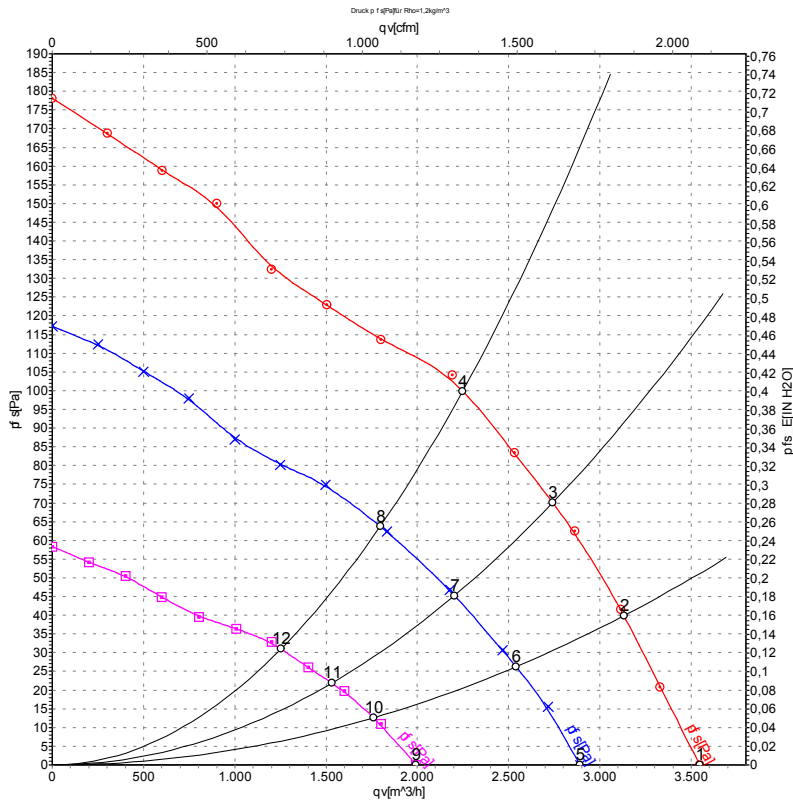

Measurement: LU-71540
Measurement: LU-71541
Measurement: LU-71542

Air performance measured as per ISO 5801 Installation category A. For detailed information on the measuring set-up, please contact ebm-papst. Suction-side noise levels: L_{WA} measured as per ISO 13347 / L_{pA} measured with 1m distance to fan axis. The values given are valid under the measuring conditions mentioned above and may vary according to the actual installation situation. With any deviation from the standard set-up, the specific values have to be checked and reviewed with the unit installed.

Measured values

	U	f	n	P _{ed}	I	qv	P _{fs}
	V	Hz	min ⁻¹	W	A	m ³ /h	Pa
1	230	50	1540	150	1.20	3545	0
2	230	50	1510	166	1.24	3130	40
3	230	50	1485	167	1.25	2740	70
4	230	50	1455	167	1.23	2250	100
5	230	50	1255	87	0.66	2890	0
6	230	50	1225	90	0.69	2540	26
7	230	50	1190	89	0.69	2205	46
8	230	50	1165	91	0.69	1795	64
9	230	50	870	33	0.27	1995	0
10	230	50	845	35	0.28	1760	13
11	230	50	830	34	0.28	1530	22
12	230	50	815	34	0.27	1255	31

U = Supply voltage · f = Frequency · n = Speed · P_{ed} = Power input · I = Current draw · qv = Air flow · p_{fs} = Pressure increase

