

EC axial fan - HyBlade

sickle-shaped blades (S series)

with guard grille for full nozzle

S3G250-BM53-11 ebmpapst Datasheet

sales@fansco.com

www.fansco.com

Nominal data

Type	S3G250-BM53-11	
Motor	M3G074-CF	
Phase		1~
Nominal voltage	VAC	230
Nominal voltage range	VAC	200 .. 240
Frequency	Hz	50/60
Method of obtaining data		ml
Speed (rpm)	min ⁻¹	3000
Power consumption	W	165
Current draw	A	1.35
Max. back pressure	Pa	200
Max. back pressure	in. wg	0.8
Min. ambient temperature	°C	-25
Max. ambient temperature	°C	60

ml = Max. load · me = Max. efficiency · fa = Free air · cs = Customer specification · ce = Customer equipment
Subject to change

Data according to Commission Regulation (EU) 327/2011 (EN 17166)

		Actual	Req. 2015			
01 Overall efficiency η_{es}	%	47.8	28.7	09 Power consumption P_{ed}	kW	0.16
02 Measurement category		A		09 Air flow q_v	m ³ /h	1220
03 Efficiency category		Static		09 Pressure increase p_{fs}	Pa	214
04 Efficiency grade N		59.1	40	10 Speed (rpm) n	min ⁻¹	2970
05 Variable speed drive		Yes		11 Specific ratio*		1.00

Data obtained at optimum efficiency level.

The ErP data is determined using a motor-impeller combination in a standardized measurement setup.

* Specific ratio = $1 + p_s / 100\,000\text{ Pa}$

LU-202687



Technical description

Size	250 mm
Motor size	74
Rotor surface	Thick-film passivated
Blade material	Press-fitted sheet steel blank, sprayed with PP plastic
Guard grille material	Steel, coated with black plastic (RAL 9005)
Number of blades	7
Airflow direction	V
Direction of rotation	Counterclockwise, viewed toward rotor
Degree of protection	IP54
Insulation class	"B"
Moisture (F) / Environmental (H) protection class	H1
Max. permitted ambient temp. for motor (transport/storage)	+80 °C
Min. permitted ambient temp. for motor (transport/storage)	-40 °C
Installation position	Shaft horizontal or rotor on bottom; rotor on top on request
Condensation drainage holes	None, open rotor
Cooling hole/opening	On rotor side
Mode	S1
Motor bearing	Ball bearing
Technical features	<ul style="list-style-type: none"> - Output 10 VDC, max. 10 mA - Tach output - Power limiter - Motor current limitation - Soft start - Control input 0-10 VDC / PWM - Control interface with SELV potential safely disconnected from the mains - Overvoltage detection - Thermal overload protection for electronics/motor - Line undervoltage detection
EMC immunity to interference	According to EN 61000-6-2 (industrial environment)
EMC interference emission	According to EN 61000-6-4 (industrial environment)
Touch current according to IEC 60990 (measuring circuit Fig. 4, TN system)	<= 3.5 mA
Motor protection	Electronic motor protection
With cable	Variable
Protection class assignment	<p>I; If a protective earth is connected by the customer</p> <p>This component for installation may have several local protection classes. This information relates to this component's basic design.</p> <p>The final protection class is based on the component's intended installation and connection.</p>
Conformity with standards	EN 60034-1; EN 60204-1; EN 60335-1; CE
Approval	CSA C22.2 No. 77 + CAN/CSA-E60730-1; UL 1004-7 + 60730-1

EC axial fan - HyBlade

sickle-shaped blades (S series)

with guard grille for full nozzle

Product drawing

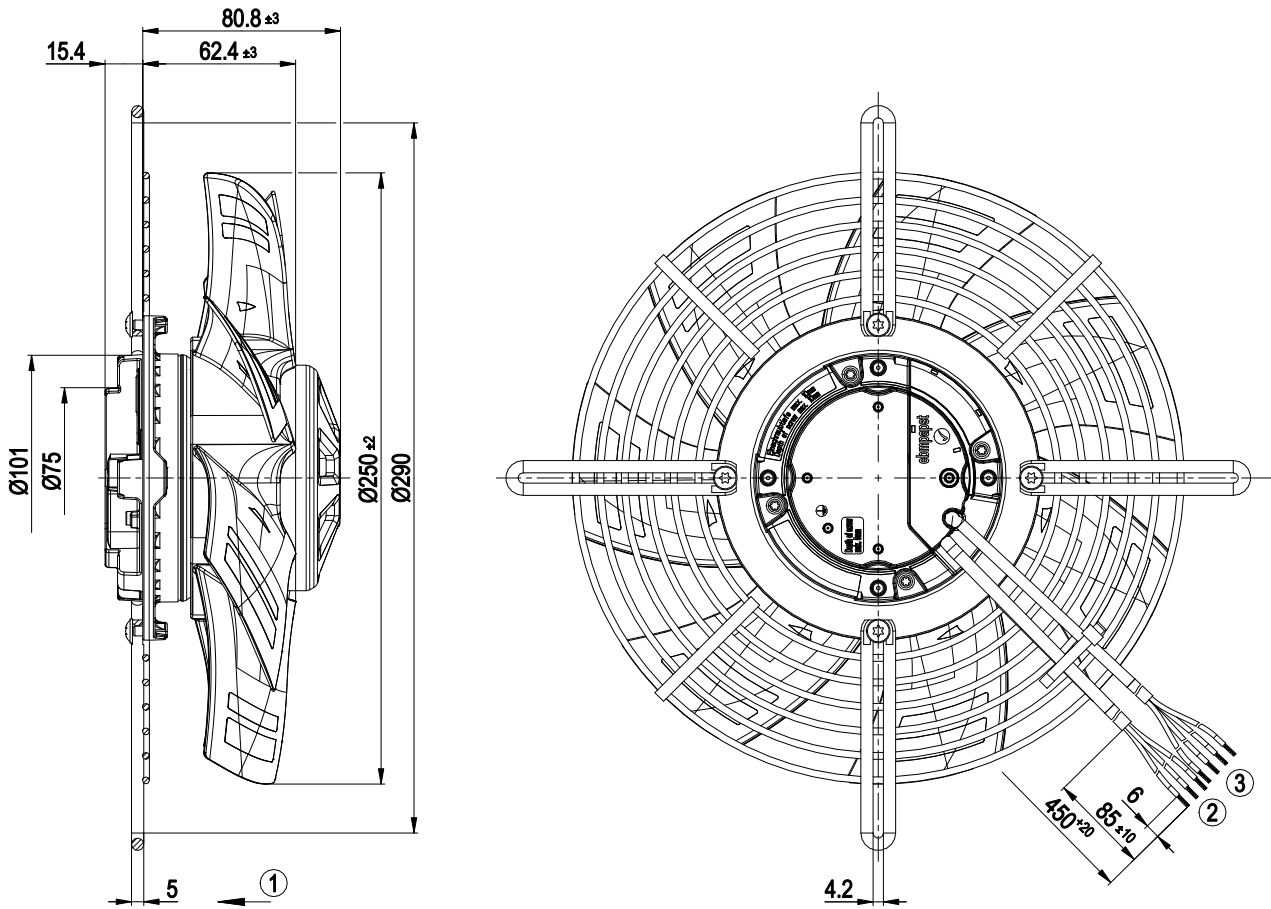

1	Airflow direction "V"
2	Cable PVC AWG20
	3x splice
3	Cable PVC AWG22
	4x splice



EC axial fan - HyBlade

sickle-shaped blades (S series)

with guard grille for full nozzle

Connection diagram

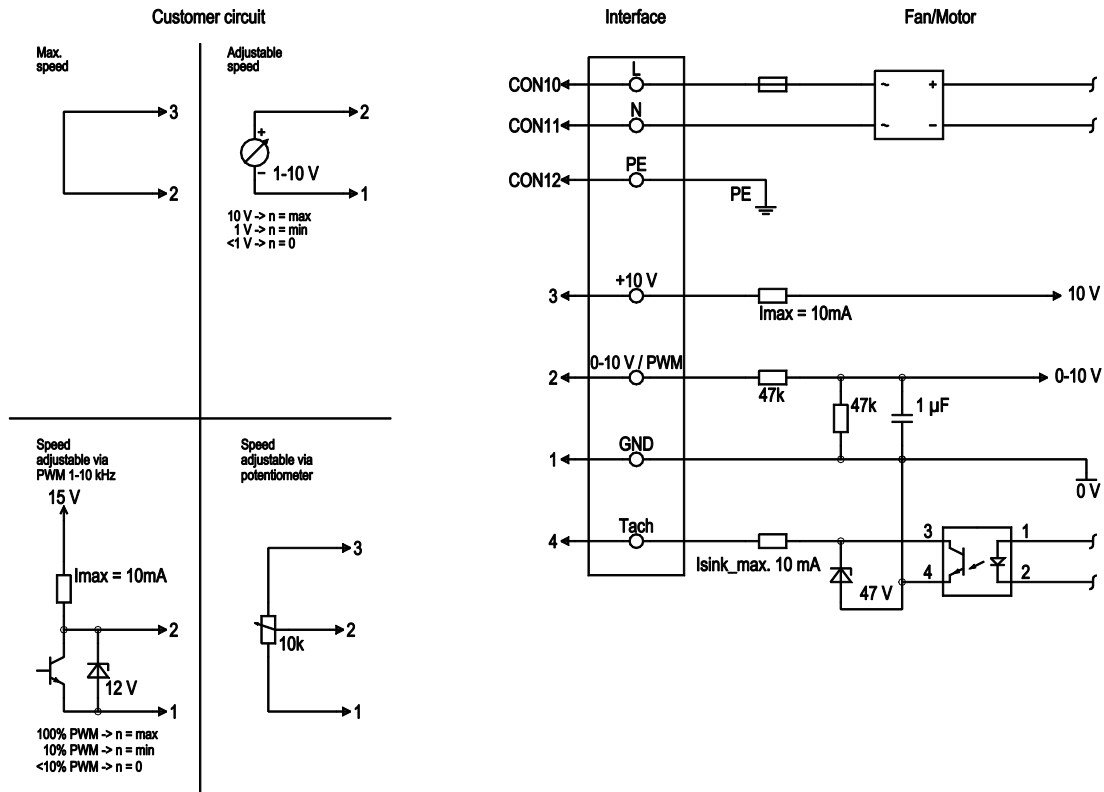

No.	Conn.	Designation	Color	Function/assignment
	CON10	L	black	Supply connection, power supply, phase, see nameplate for voltage range
	CON11	N	blue	Supply connection, power supply, neutral conductor, see nameplate for voltage range
	CON12	PE	green/yellow	Ground connection
	2	0- 10V PWM	yellow	0-10 V / PWM control input, R _i =100 kΩ, SELV
	4	Tach	white	Tach output, open collector, 1 pulse per revolution, I _{sink max} = 10 mA, SELV
	3	+10 V	red	Fixed voltage output 10 VDC +/-3 %, I _{max} . 10 mA, short-circuit-proof, power supply for ext. devices (e.g. pot), SELV
	1	GND	blue	Reference ground for control interface, SELV



EC axial fan - HyBlade

sickle-shaped blades (S series)

with guard grille for full nozzle

Curves: Air performance 50 Hz

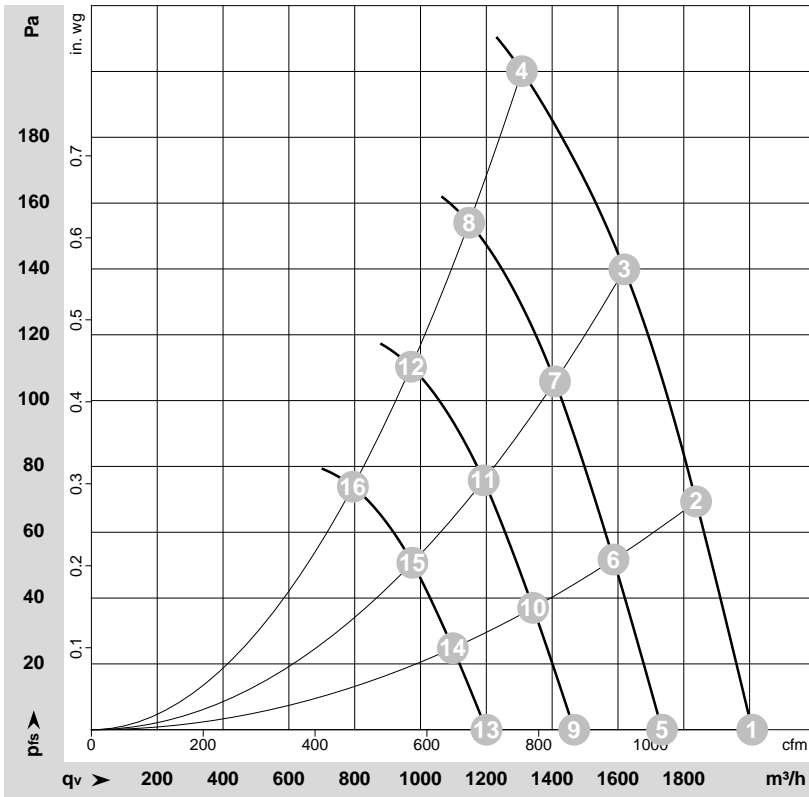

$\rho = 1.15 \text{ kg/m}^3 \pm 2 \%$

Measurement: LU-202687-1

Air performance measured according to ISO 5801 installation category A. For detailed information on the measurement setup, contact ebmpapst. Intake sound level: Sound power level according to ISO 13347 / sound pressure level measured at 1 m distance from fan axis. The values given are valid under the specified measuring conditions and may vary due to conditions of installation. For deviations from the standard configuration, the parameters have to be checked on the installed unit.

Measured values

	Wired	U	f	n	P _{ed}	I	q _v	P _{fs}	q _v	P _{fs}
		V	Hz	min ⁻¹	W	A	m ³ /h	Pa	cfm	in. wg
1	1~	230	50	3000	127	1.05	2010	0	1180	0.00
2	1~	230	50	3000	147	1.20	1835	70	1080	0.28
3	1~	230	50	3000	165	1.35	1620	140	955	0.56
4	1~	230	50	3000	165	1.35	1310	200	770	0.80
5	1~	230	50	2600	82	0.67	1735	0	1020	0.00
6	1~	230	50	2600	95	0.77	1585	52	935	0.21
7	1~	230	50	2600	106	0.86	1410	106	830	0.43
8	1~	230	50	2600	111	0.90	1150	154	675	0.62
9	1~	230	50	2200	49	0.41	1465	0	865	0.00
10	1~	230	50	2200	57	0.47	1340	37	790	0.15
11	1~	230	50	2200	64	0.52	1190	76	700	0.31
12	1~	230	50	2200	67	0.54	970	110	570	0.44
13	1~	230	50	1800	27	0.22	1200	0	705	0.00
14	1~	230	50	1800	31	0.26	1100	25	645	0.10
15	1~	230	50	1800	35	0.29	975	51	575	0.20
16	1~	230	50	1800	37	0.30	795	74	470	0.30

Wired = Wiring · U = Voltage · f = Frequency · n = Speed (rpm) · P_{ed} = Power consumption · I = Current draw · q_v = Air flow · p_s = Pressure increase

