

# AC axial panel fan

sickle-shaped blades (S series)  
with guard grille for short nozzle



S2E300-AP02-50 ebmpapst Datasheet

sales@fansco.com

www.fansco.com

## Nominal data

Type	S2E300-AP02-50		
Motor	M2E074-DF		
Phase		1~	1~
Nominal voltage	VAC	230	230
Frequency	Hz	50	60
Method of obtaining data		fa	fa
Valid for approval/standard		CE	CE
Speed (rpm)	min <sup>-1</sup>	2700	3000
Power consumption	W	230	350
Current draw	A	1.10	1.55
Capacitor	μF	8	8
Capacitor voltage	VDB	400	400
Capacitor standard		S0 (CE)	S0 (CE)
Max. back pressure	Pa	160	50
Max. back pressure	in. wg	0.64	0.2
Min. ambient temperature	°C	-25	-25
Max. ambient temperature	°C	70	50

ml = Max. load · me = Max. efficiency · fa = Free air · cs = Customer specification · ce = Customer equipment  
Subject to change

## Data according to Commission Regulation (EU) 327/2011 (prEN 17166)

	Actual	Req. 2015				
01 Overall efficiency $\eta_{es}$	%	30.4	30.2	09 Power consumption $P_e$	kW	0.28
02 Measurement category		A		09 Air flow $q_v$	m <sup>3</sup> /h	2245
03 Efficiency category		Static		09 Pressure increase $p_{fs}$	Pa	143
04 Efficiency grade N		40.2	40	10 Speed (rpm) n	min <sup>-1</sup>	2605
05 Variable speed drive		No		11 Specific ratio*		1.00

Data obtained at optimum efficiency level.

\* Specific ratio =  $1 + p_{fs} / 100\,000\text{ Pa}$ 

LU-77994

The efficiency values displayed for achieving conformity with the Ecodesign Regulation EU 327/2011 has been reached with defined air duct components (e.g. inlet rings).  
The dimensions must be requested from ebm-papst. If other air conduction geometries are used on the installation side, the ebm-papst evaluation loses its validity/the conformity must be confirmed again.  
The product does not fall within the scope of Regulation (EU) 2019/1781 due to the exception specified in Article 2 (2a) (motors completely integrated into a product).

# AC axial panel fan

sickle-shaped blades (S series)  
with guard grille for short nozzle

## Technical description

Weight	3.5 kg
Size	300 mm
Motor size	74
Rotor surface	Painted black
Terminal box material	PP plastic
Blade material	Sheet steel, painted black
Guard grille material	Steel, coated with black plastic (RAL 9005)
Number of blades	5
Airflow direction	V
Direction of rotation	Counterclockwise, viewed toward rotor
Degree of protection	IP44; installation- and position-dependent as per EN 60034-5
Insulation class	"F"
Moisture (F) / Environmental (H) protection class	H1
Max. permitted ambient temp. for motor (transport/storage)	+ 80 °C
Min. permitted ambient temp. for motor (transport/storage)	- 40 °C
Installation position	Shaft horizontal or rotor on bottom; rotor on top on request
Condensation drainage holes	On rotor side
Mode	S1
Motor bearing	Ball bearing
Touch current according to IEC 60990 (measuring circuit Fig. 4, TN system)	< 0.75 mA
Electrical hookup	Terminal box; Via terminal box, capacitor integrated and connected
Motor protection	Thermal switch auto reset, internally connected
With cable	Variable
Protection class assignment	I; If a protective earth is connected to the PE connection point. The built-in component has several local protection class assignments. The final protection class is determined by the intended installation.
Motor capacitor according to EN 60252-1 in safety protection class	S0
Conformity with standards	EN 60335-1; CE
Approval	CCC; EAC

# AC axial panel fan

sickle-shaped blades (S series)  
with guard grille for short nozzle

## Product drawing

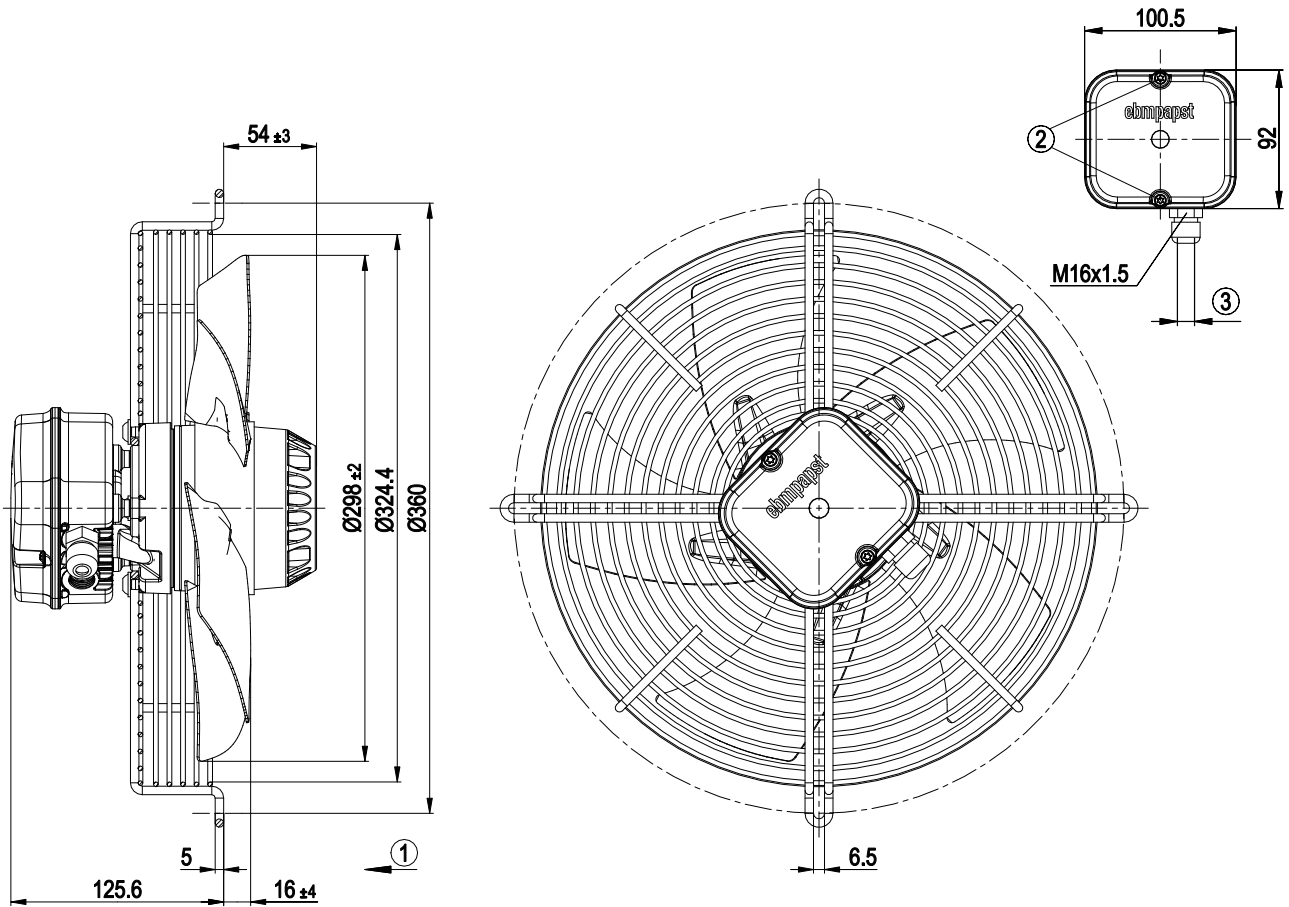

1	Direction of air flow "V"
2	Tightening torque 1.5 ± 0.2 Nm
3	Cable diameter max. 7.5 mm, tightening torque 1.3±0.2 Nm

## Connection diagram

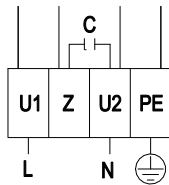

L	= U1 = blue	Z	brown	N	= U2 = black
PE	green/yellow				

# AC axial panel fan

sickle-shaped blades (S series)  
with guard grille for short nozzle

## Curves: Air performance 50 Hz

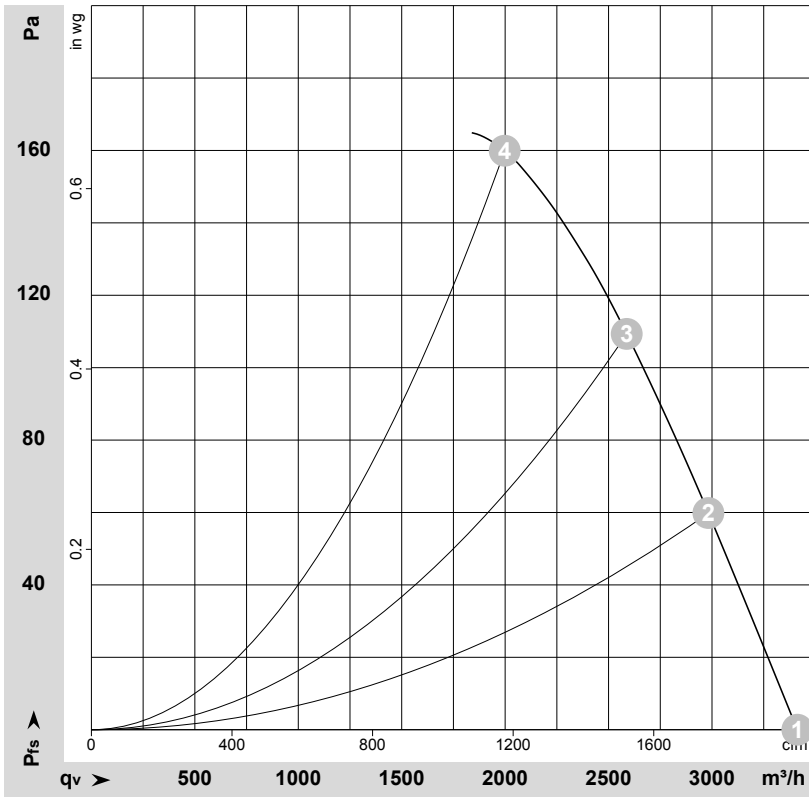

$\rho = 1.15 \text{ kg/m}^3 \pm 2 \%$

Measurement: LU-29177-1  
Date: 1996-07-04  
Housing: 03968-2-4037

Air performance measured according to ISO 5801 installation category A. For detailed information on the measurement setup, contact ebm-papst. Intake sound level: Sound power level according to ISO 13347 / sound pressure level measured at 1 m distance from fan axis. The values given are valid under the specified measuring conditions and may vary due to conditions of installation. For deviations from the standard configuration, the parameters have to be checked on the installed unit.

## Measured values

	U	f	n	P <sub>e</sub>	I	LpA <sub>in</sub>	LwA <sub>in</sub>	q <sub>v</sub>	p <sub>fs</sub>	q <sub>v</sub>	p <sub>fs</sub>
	V	Hz	min <sup>-1</sup>	W	A	dB(A)	dB(A)	m <sup>3</sup> /h	Pa	cfm	in. wg
1	230	50	2700	230	1.10	73	80	3415	0	2010	0.00
2	230	50	2675	256	1.12	73	80	2985	60	1755	0.24
3	230	50	2615	275	1.20	73	80	2590	110	1525	0.44
4	230	50	2540	300	1.31	74	82	2000	160	1175	0.64

U = Voltage · f = Frequency · n = Speed (rpm) · P<sub>e</sub> = Power consumption · I = Current draw · LpA<sub>in</sub> = Sound pressure level intake side · LwA<sub>in</sub> = Sound power level intake side  
q<sub>v</sub> = Air flow · p<sub>fs</sub> = Pressure increase

# AC axial panel fan

sickle-shaped blades (S series)  
with guard grille for short nozzle

## Curves: Air performance 60 Hz

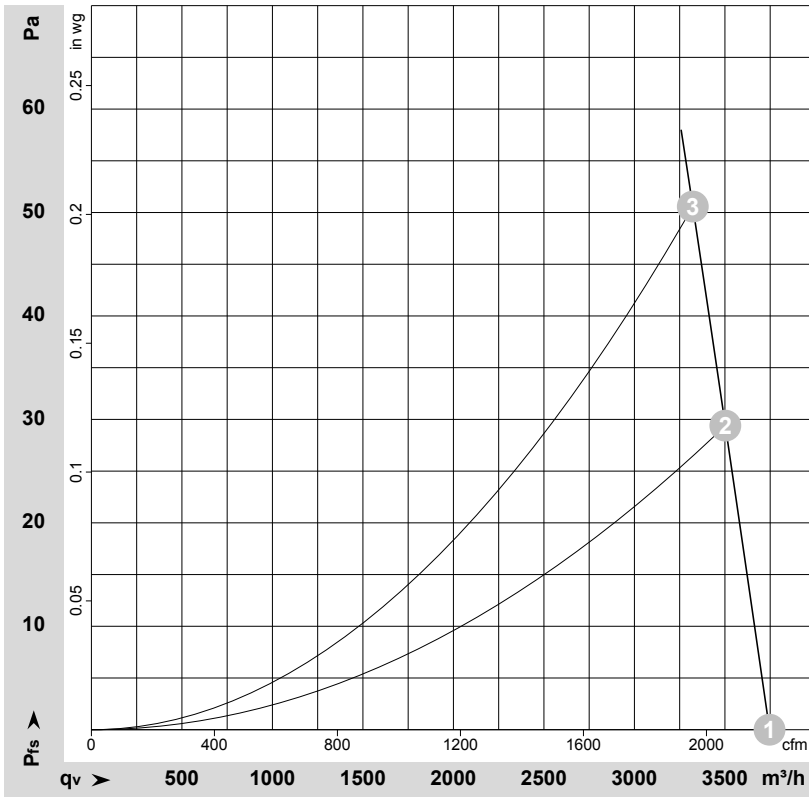

$\rho = 1.15 \text{ kg/m}^3 \pm 2 \%$

Measurement: LU-29105-1  
Date: 1996-06-27  
Housing: 03968-2-4037

Air performance measured according to ISO 5801 installation category A. For detailed information on the measurement setup, contact ebmpapst. Intake sound level: Sound power level according to ISO 13347 / sound pressure level measured at 1 m distance from fan axis. The values given are valid under the specified measuring conditions and may vary due to conditions of installation. For deviations from the standard configuration, the parameters have to be checked on the installed unit.

## Measured values

	U	f	n	P <sub>e</sub>	I	LpA <sub>in</sub>	LwA <sub>in</sub>	q <sub>v</sub>	P <sub>fs</sub>	q <sub>v</sub>	P <sub>fs</sub>
	V	Hz	min <sup>-1</sup>	W	A	dB(A)	dB(A)	m <sup>3</sup> /h	Pa	cfm	in. wg
1	230	60	3000	350	1.55	77	84	3745	0	2205	0.00
2	230	60	2930	357	1.58	76	83	3500	30	2060	0.12
3	230	60	2875	362	1.60	75	83	3325	50	1955	0.20

U = Voltage · f = Frequency · n = Speed (rpm) · P<sub>e</sub> = Power consumption · I = Current draw · LpA<sub>in</sub> = Sound pressure level intake side · LwA<sub>in</sub> = Sound power level intake side  
q<sub>v</sub> = Air flow · P<sub>fs</sub> = Pressure increase