

# AC axial fan

straight blades (A series)

with guard grille for full nozzle

S2D200-BA02-02 ebmpapst Datasheet

sales@fansco.com

www.fansco.com

## Nominal data

|                             |                       |      |      |      |
|-----------------------------|-----------------------|------|------|------|
| <b>Type</b>                 | <b>S2D200-BA02-02</b> |      |      |      |
| <b>Motor</b>                | <b>M2D068-CF</b>      |      |      |      |
| Phase                       |                       | 3~   | 3~   | 3~   |
| Nominal voltage             | VAC                   | 230  | 400  | 400  |
| Wiring                      |                       | Δ    | Y    | Y    |
| Frequency                   | Hz                    | 50   | 50   | 60   |
| Method of obtaining data    |                       | fa   | fa   | fa   |
| Valid for approval/standard |                       | CE   | CE   | CE   |
| Speed (rpm)                 | min <sup>-1</sup>     | 2800 | 2800 | 3150 |
| Power consumption           | W                     | 53   | 53   | 70   |
| Current draw                | A                     | 0.26 | 0.15 | 0.14 |
| Max. back pressure          | Pa                    | 200  | 200  | 300  |
| Max. back pressure          | inH <sub>2</sub> O    | 0.8  | 0.8  | 1.2  |
| Min. ambient temperature    | °C                    | -25  | -25  | -25  |
| Max. ambient temperature    | °C                    | 75   | 75   | 75   |
| Starting current            | A                     | 0.81 | 0.47 | 0.45 |

ml = Max. load · me = Max. efficiency · fa = Free air · cs = Customer specification · ce = Customer equipment  
Subject to change



# AC axial fan

straight blades (A series)  
with guard grille for full nozzle

## Technical description

|   |  |
|---|--|
| <b>Weight</b>   | 1.7 kg   |
| <b>Fan size</b>   | 200 mm   |
| <b>Rotor surface</b>  | Painted black  |
| <b>Impeller material</b>  | Sheet steel, painted black   |
| <b>Guard grille material</b>  | Steel, coated with black plastic (RAL 9005)                                  |
| <b>Number of blades</b>   | 5  |
| <b>Airflow direction</b>  | "A"  |
| <b>Direction of rotation</b>  | Clockwise, viewed toward rotor   |
| <b>Degree of protection</b>   | IP44; installation- and position-dependent as per EN 60034-5                 |
| <b>Insulation class</b>   | "B"  |
| <b>Moisture (F) / Environmental (H) protection class</b>                          | H0+  |
| <b>Max. permitted ambient temp. for motor (transport/storage)</b>                 | + 80 °C  |
| <b>Min. permitted ambient temp. for motor (transport/storage)</b>                 | - 40 °C  |
| <b>Installation position</b>  | Shaft horizontal or rotor on bottom; rotor on top on request                 |
| <b>Condensation drainage holes</b>  | On rotor side  |
| <b>Mode</b>   | S1   |
| <b>Motor bearing</b>  | Ball bearing   |
| <b>Touch current according to IEC 60990 (measuring circuit Fig. 4, TN system)</b> | < 0.75 mA  |
| <b>With cable</b>   | Lateral  |
| <b>Protection class</b>   | I (with customer connection of protective earth)                             |
| <b>Conformity with standards</b>  | EN 60335-1, motor does not have factory-installed overheating protection; CE |
| <b>Approval</b>   | EAC  |



# AC axial fan

straight blades (A series)

with guard grille for full nozzle

## Product drawing

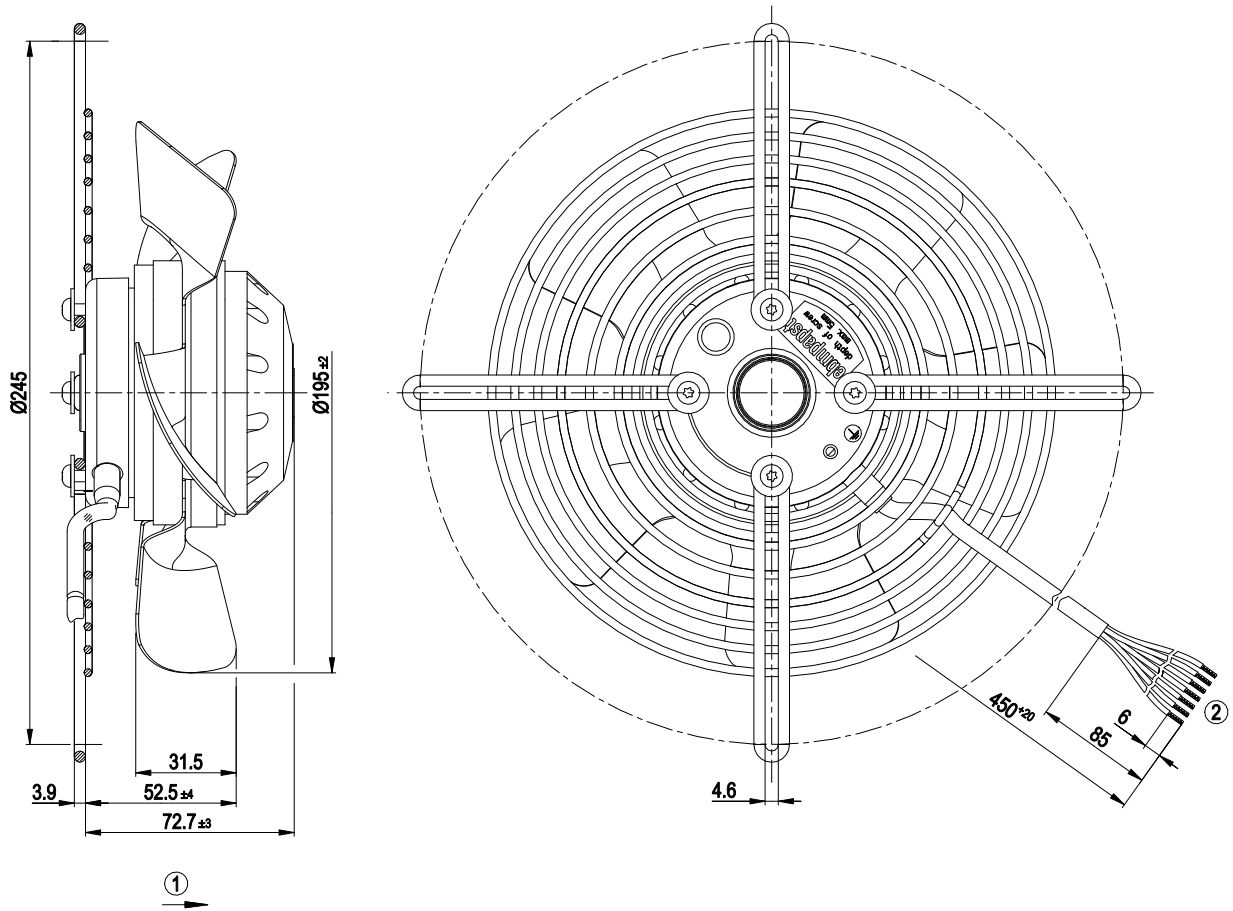

- |   |   |
|---|---|
| 1 | Direction of air flow "A"                             |
| 2 | Cable PVC 7G 0.5 mm <sup>2</sup> , 7x crimped splices |



# AC axial fan

straight blades (A series)

with guard grille for full nozzle

## Connection diagram

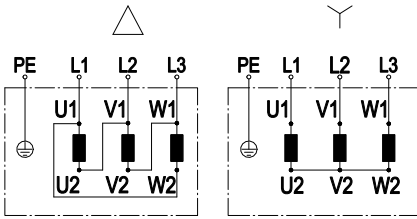

Change of rotation direction by reversing two phases

|    |                   |    |                  |    |                 |
|----|-------------------|----|------------------|----|-----------------|
|    | Three-phase motor | Δ  | Delta connection | Y  | Star connection |
| L1 | = U1 = black      | L2 | = V1 = blue      | L3 | = W1 = brown    |
| U2 | green             | V2 | white            | W2 | yellow          |
| PE | green/yellow      |    |                  |    |                 |



# AC axial fan

straight blades (A series)  
with guard grille for full nozzle

## Curves: Air performance 50 Hz

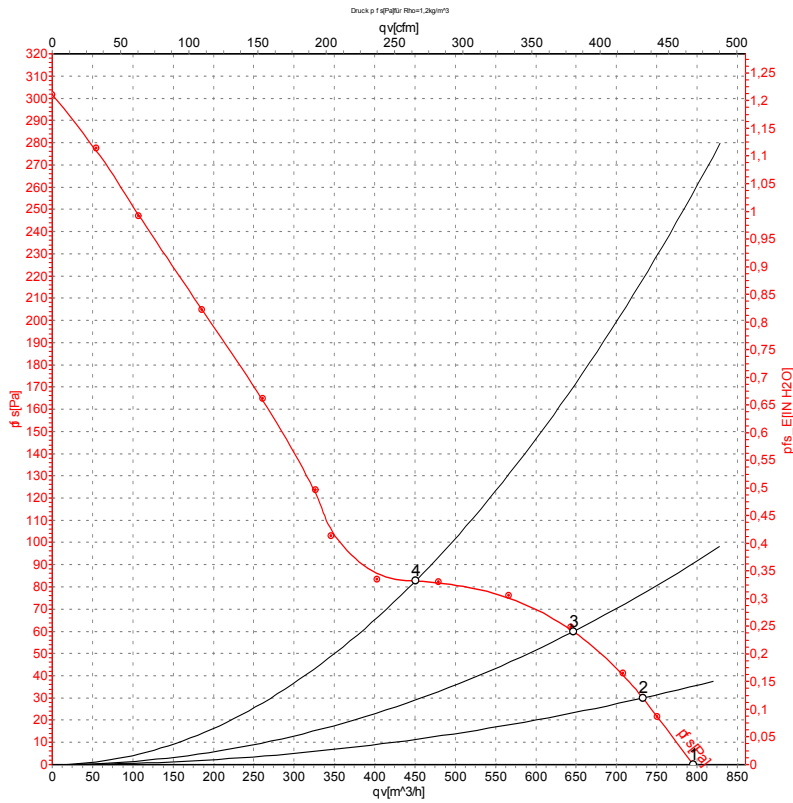

Measurement: LU-58516-1

Air performance measured according to ISO 5801 installation category A. For detailed information on the measurement setup, contact ebm-papst. Intake sound level: Sound power level according to ISO 13347 / sound pressure level measured at 1 m distance from fan axis. The values given are valid under the specified measuring conditions and may vary due to conditions of installation. For deviations from the standard configuration, the parameters have to be checked on the installed unit.

### Measured values

|   | U   | f  | n                 | P <sub>e</sub> | I    | qv                | p <sub>fs</sub> | qv  | p <sub>fs</sub>    |
|---|-----|----|-------------------|----------------|------|-------------------|-----------------|-----|--------------------|
|   | V   | Hz | min <sup>-1</sup> | W              | A    | m <sup>3</sup> /h | Pa              | CFM | inH <sub>2</sub> O |
| 1 | 400 | 50 | 2800              | 53             | 0.15 | 800               | 0               | 470 | 0.00               |
| 2 | 400 | 50 | 2800              | 54             | 0.15 | 735               | 30              | 430 | 0.12               |
| 3 | 400 | 50 | 2800              | 56             | 0.15 | 645               | 60              | 380 | 0.24               |
| 4 | 400 | 50 | 2800              | 52             | 0.15 | 450               | 83              | 265 | 0.33               |

U = Power supply · f = Frequency · n = Speed (rpm) · P<sub>e</sub> = Power consumption · I = Current draw · qv = Air flow · p<sub>fs</sub> = Pressure increase



# AC axial fan

straight blades (A series)  
with guard grille for full nozzle

## Curves: Air performance 60 Hz

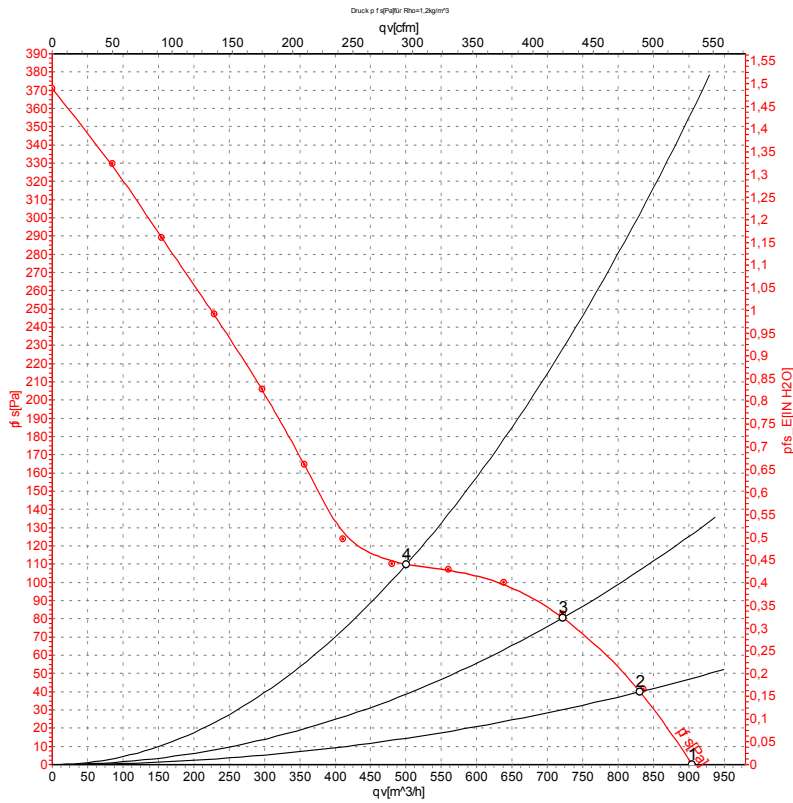

Measurement: LU-58517-1

Air performance measured according to ISO 5801 installation category A. For detailed information on the measurement setup, contact ebm-papst. Intake sound level: Sound power level according to ISO 13347 / sound pressure level measured at 1 m distance from fan axis. The values given are valid under the specified measuring conditions and may vary due to conditions of installation. For deviations from the standard configuration, the parameters have to be checked on the installed unit.

## Measured values

|   | U   | f  | n                 | P <sub>e</sub> | I    | qv                | p <sub>fs</sub> | qv  | p <sub>fs</sub> |
|---|-----|----|-------------------|----------------|------|-------------------|-----------------|-----|-----------------|
|   | V   | Hz | min <sup>-1</sup> | W              | A    | m <sup>3</sup> /h | Pa              | CFM | inH2O           |
| 1 | 400 | 60 | 3150              | 70             | 0.14 | 910               | 0               | 535 | 0.00            |
| 2 | 400 | 60 | 3150              | 71             | 0.14 | 830               | 40              | 490 | 0.16            |
| 3 | 400 | 60 | 3150              | 74             | 0.14 | 720               | 80              | 425 | 0.32            |
| 4 | 400 | 60 | 3150              | 69             | 0.13 | 500               | 110             | 295 | 0.44            |

U = Power supply · f = Frequency · n = Speed (rpm) · P<sub>e</sub> = Power consumption · I = Current draw · qv = Air flow · p<sub>fs</sub> = Pressure increase

