

S1G200-CA91-21

EC axial fan

sickled blades (S series)

ESM guard grille



S1G200-CA91-21 ebmpapst Datasheet FansCo

sales@fansco.com

www.fansco.com

Nominal data

Type	S1G200-CA91-21		
Motor	M1G055-BD		
Phase		1~	1~
Nominal voltage	VAC	230	230
Frequency	Hz	50/60	50/60
Type of data definition		ml	-
Speed	min ⁻¹	2000	1500
Power input	W	34	-
Current draw	A	0.26	
Max. back pressure	Pa	45	
Min. ambient temperature	°C	-30	-30
Max. ambient temperature	°C	60	60

ml = max. load · me = max. efficiency · fa = running at free air · cs = customer specs · cu = customer unit
Subject to alterations



Technical features

Mass	1 kg
Size	200 mm
Material of impeller	PA plastic
Material of guard grille	PP plastic
Number of blades	5
Direction of air flow	"A"
Direction of rotation	Counter-clockwise, seen on rotor
Type of protection	IP 54
Insulation class	"B"
Humidity class	F3-1
Max. permissible ambient motor temp. (transp./ storage)	+ 80 °C
Min. permissible ambient motor temp. (transp./storage)	- 40 °C
Mounting position	Any
Condensate discharge holes	None
Operation mode	S1
Motor bearing	Ball bearing
Technical features	<ul style="list-style-type: none"> - Speed selection max/min - Soft start - Over-temperature protected motor
Speed steps	2
EMC interference immunity	Acc. to EN 61000-6-2 (industrial environment)
EMC harmonics	Acc. to EN 61000-3-2/3
EMC interference emission	Acc. to EN 61000-6-3 (household environment)
Motor protection	Thermal overload protector (TOP) wired internally
Protection class	II
Product conforming to standard	EN 60335-1; CE
Approval	UL 507; CSA C22.2 Nr.113; VDE

EC axial fan

sickled blades (S series)

ESM guard grille

Product drawing

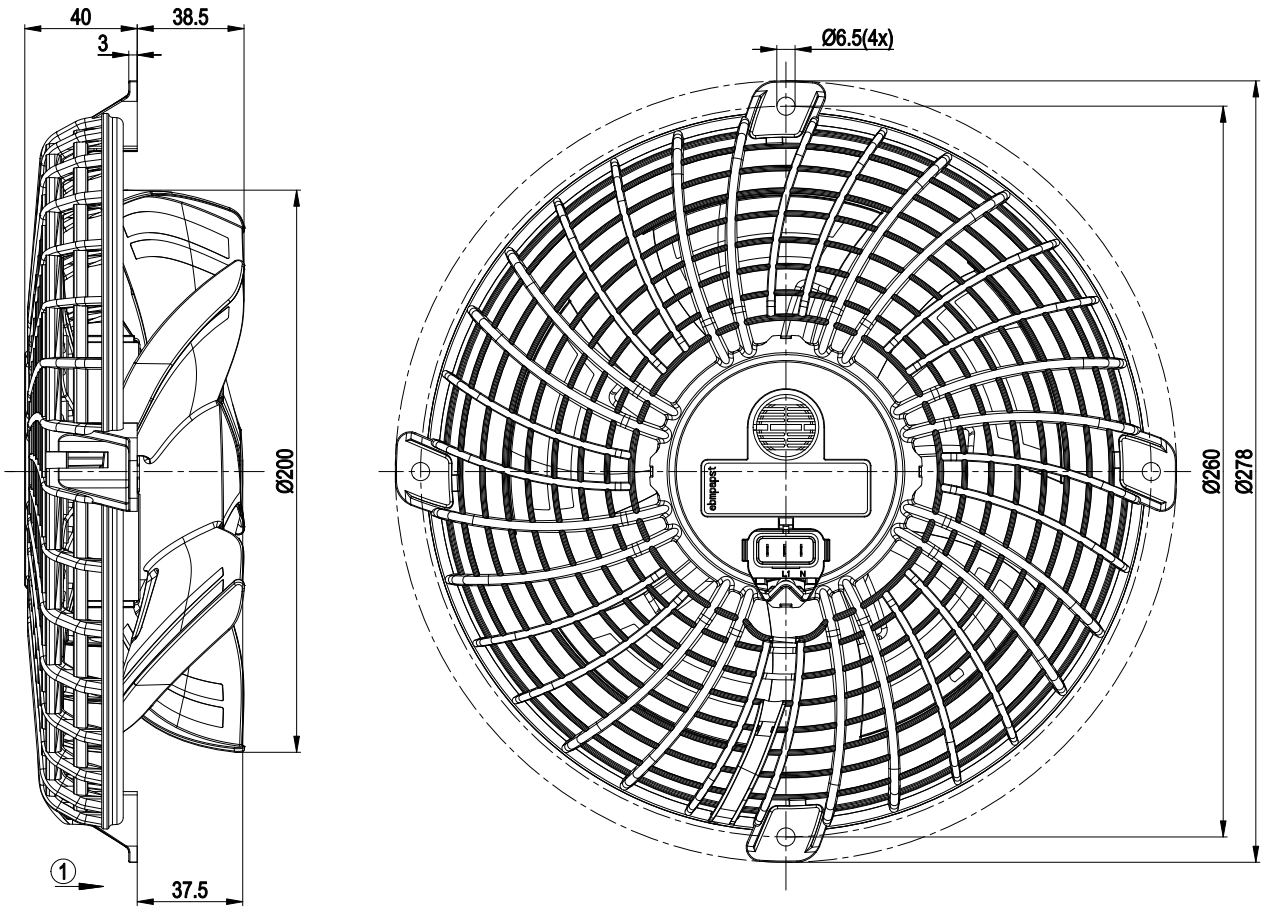

1 Direction of air flow "A"

Connection screen

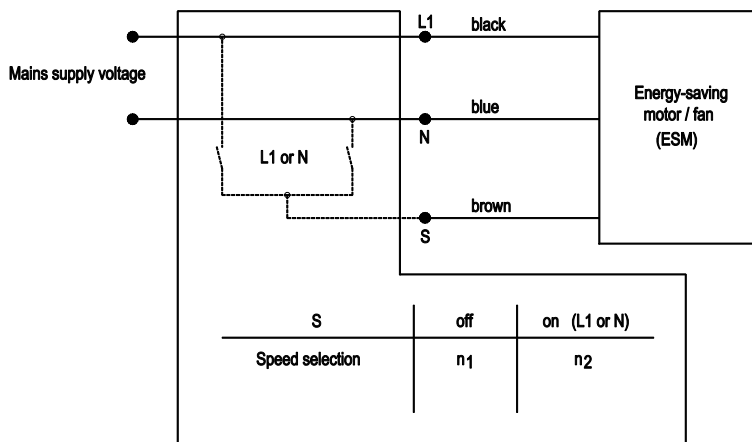

Charts: Air flow 50 Hz

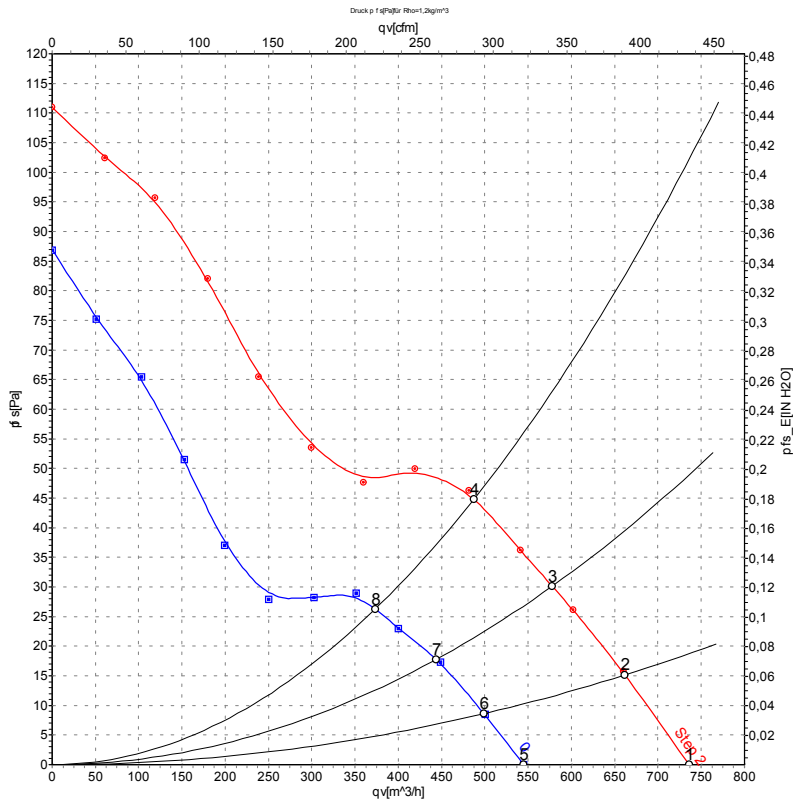

Measurement: LU-113009
Measurement: LU-113010

Air performance measured as per ISO 5801 Installation category A. For detailed information on the measuring set-up, please contact ebm-papst. Suction-side noise levels: LwA measured as per ISO 13347 / LpA measured with 1m distance to fan axis. The values given are valid under the measuring conditions mentioned above and may vary according to the actual installation situation. With any deviation from the standard set-up, the specific values have to be checked and reviewed with the unit installed.

Measured values

	Stage	U	f	n	P _{ed}	I	LpA _{in}	LwA _{in}	qv	p _{fs}
		V	Hz	min ⁻¹	W	A	dB(A)	dB(A)	m ³ /h	Pa
1	2	230	50	2000	32	0.24	54	64	735	0
2	2	230	50	2000	33	0.25	54	64	660	15
3	2	230	50	2000	33	0.26	53	63	580	30
4	2	230	50	2000	34	0.26	54	64	485	45
5	2	230	50	1500	18	0.16	50	59	545	0
6	2	230	50	1500	19	0.16	50	58	500	9
7	2	230	50	1500	19	0.16	49	58	445	18
8	2	230	50	1500	20	0.16	50	59	375	26

U = Supply voltage · f = Frequency · n = Speed · P_{ed} = Power input · I = Current draw · LpA_{in} = Sound pressure level inlet side · LwA_{in} = Sound power level inlet side · qv = Air flow
p_{fs} = Pressure increase

