

Product Data Sheet

9592207002

VHS0048XUEBS

RL48-19/14

ebmpapst

engineering a better life

RL48-19/14 (9592207002) ebmpapst Datasheet
sales@fansco.com www.fansco.com



RL48-19/14

INDEX

- 1 General 3**
- 2 Mechanics 3**
 - 2.1 General 3
 - 2.2 Connections 3
- 3 Operating Data 4**
 - 3.1 Electrical Operating Data 4
 - 3.2 Electrical Features 5
 - 3.3 Aerodynamics 6
 - 3.4 Sound Data 7
- 4 Environment 7**
 - 4.1 General 7
 - 4.2 Climatic Requirements 7
 - 4.3 EMC 7
- 5 Safety 9**
 - 5.1 Electrical Safety 9
 - 5.2 Approval Tests 9
- 6 Reliability 9**
 - 6.1 General 9

1 General

Fan type	Blower	
Rotating direction looking at rotor	Counterclockwise	
Airflow direction	Axial: intake; centrifugal: exhaust	
Bearing system	Ball bearing	
Mounting position - shaft	Any	

2 Mechanics

2.1 General

Width	76,0 mm	
Height	76,0 mm	
Depth	27,0 mm	
Mass	0,075 kg	
Housing material	Plastic	
Impeller material	Plastic	
Max. torque when mounted across both mounting flanges	Wire outlet corner: 120 Ncm Remaining corners: 120 Ncm	
Screw size	ISO 4762 - M4 degreased, without an additional brace and without washer	

2.2 Connections

Electrical connection	Wires	
Lead wire length	L = 310 mm	
Tolerance	+/- 10,0 mm	



Wire	Color	Operation	Wire size	Insulation diameter
1	red	+ UB	AWG 26	1,35 mm
2	blue	- GND	AWG 26	1,35 mm

3 Operating Data

3.1 Electrical Operating Data

Measurement conditions: Normal air density = 1,2 kg/m³; Temperature 23°C +/- 3°C; Motor axis horizontal; warm-up time before measuring 5 minutes (unless otherwise specified). In the intake and outlet area should not be any solid obstruction within 0,5 m.

$\Delta p = 0$: corresp. to free air flow (see chapter aerodynamics)
I: corresp. to arithm. mean current value

Features	Condition	Symbol	Values		
Voltage range		U	18 V		26,4 V
Nominal voltage		U _N		24,0 V	
Power consumption	$\Delta p = 0$	P	1,8 W	3,3 W	4 W
Tolerance	0010		+/- 17,5 %	+/- 12,5 %	+/- 17,5 %
Current consumption	$\Delta p = 0$	I	97 mA	136 mA	151 mA
Tolerance	0010		+/- 17,5 %	+/- 12,5 %	+/- 17,5 %
Speed	$\Delta p = 0$	n	3.680 1/min	4.400 1/min	4.800 1/min
Tolerance	0010		+/- 15,0 %	+/- 10,0 %	+/- 15,0 %
Starting current consumption				300 mA	

3.2 Electrical Features

Electronic function	None	
Reversed polarity protection	Rectifying diode	
Max. residual current at U_N	$I_F \leq 1 \text{ mA}$	
Locked rotor protection	Auto restart	
Locked rotor current at U_N	I_{block} approx. 285 mA	
Clock signal at locked rotor	t_3 / t_4 typical: 0,33 s / 4 s	

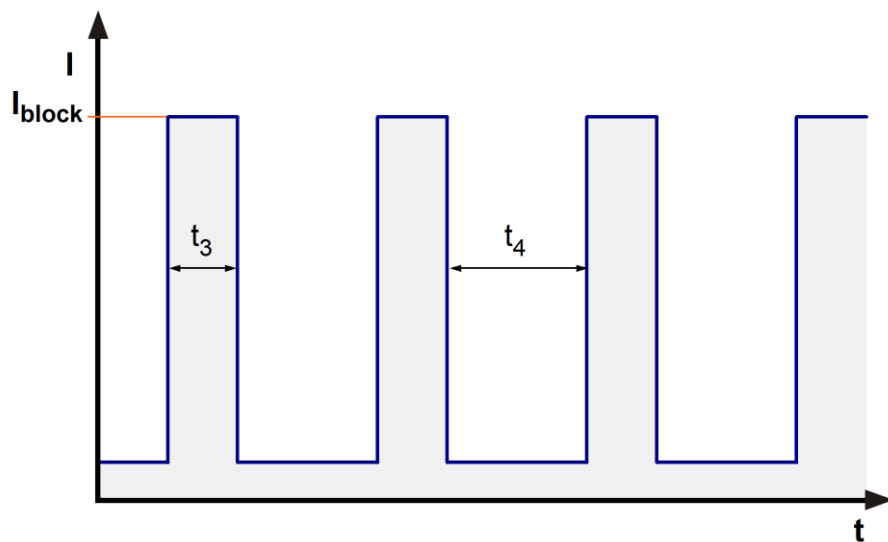

locked rotor current at 24V

running current at 24V
 start up current at 24V

3.3 Aerodynamics

Measurement conditions: Measured with a double chamber intake rig acc. to DIN EN ISO 5801. Normal air density = 1,2 kg/m³; Temperature 23°C +/- 3°C; In the intake and outlet area should not be any solid obstruction within 0,5 m. Motor shaft horizontal.

The information is only valid under the specified test conditions and may be changed by the installation conditions. If there are deviations from the standard test conditions, the characteristic values must be checked under the installed conditions. Power consumption of the fan motor when operating at normal voltage is shown. Depending on the operating conditions of the application, the power input may be higher.

a.) Operation condition:

4.400 1/min at free air flow

Max. free-air flow ($\Delta p = 0 / \dot{V} = \text{max.}$)	25 m ³ /h	
Max. static pressure ($\Delta p = \text{max.} / \dot{V} = 0$)	140 Pa	

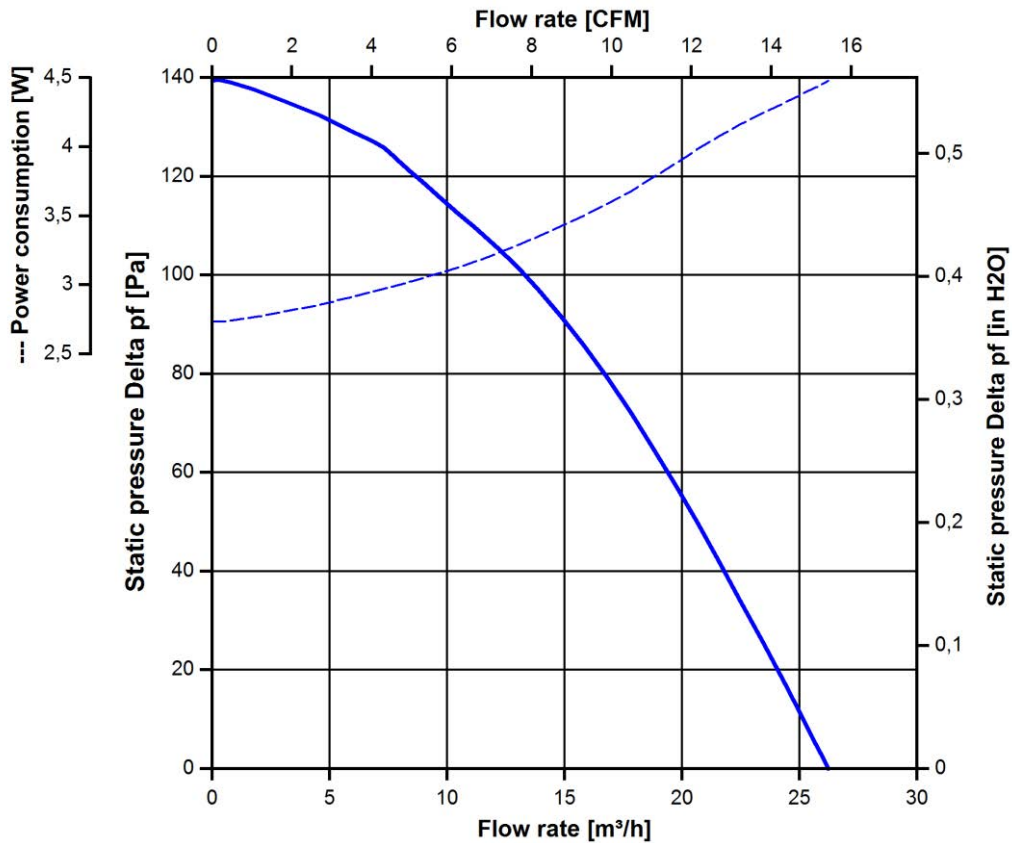

3.4 Sound Data

Measurement conditions: Sound pressure level: 1 meter distance between microphone and the air intake.
Sound power level: According to DIN 45635 Part 38 (ISO 10302)
Measured in a semianechoic chamber with a background noise level of $L_p(A) < 5 \text{ dB}(A)$
For further measurement conditions see chapter aerodynamics.

a.) Operation condition:

4.400 1/min at free air flow		
Optimal operating point	19,0 m ³ /h @ 62 Pa	
Sound power level at the optimal operating point	5,6 bel(A)	
Sound pressure level at free air flow, measured in rubber bands		

4 Environment

4.1 General

Min. permitted ambient temperature TU min.	-20 °C	
Max. permitted ambient temperature TU max.	70 °C	
Min. permitted storage temperature TL min.	-40 °C	
Max. permitted storage temperature TL max.	80 °C	

4.2 Climatic Requirements

Humidity requirements	humid heat, constant; according to DIN EN 60068-2-78, 14 days	
Water exposure	None	
Dust requirements	None	
Salt fog requirements	None	

Permitted application area:

The product is intended for use in sheltered rooms with controlled temperature and controlled humidity. Directly exposure to water must be avoided.

Pollution degree 1 (according DIN EN 60664-1)

There is either no pollution or it occurs only dry, non-conductive pollution. The pollution has no negative impact.

Please require severity levels and specification parameters from the responsible development departments.

4.3 EMC

Kind	Conducted Emission; Voltage; 150 kHz-30 MHz (without PE)
According	DIN EN 55032:2016-02
Check accuracy / Limit	Class B
Result	Below limit Class B

Kind	Radiated Emission; 30 MHz - 1000 MHz (without PE)
According	DIN EN 55032:2016-02
Check accuracy / Limit	Class B
Result	Below limit Class B

Kind	Electromagnetic Field Immunity Test
According	DIN EN 61000-4-3:2006-12
Check accuracy / Limit	10 V/m; 80 - 1000 MHz; AM; m = 0,8; f = 1 kHz; 1%; t = 3 s
Result	A: The monitored function operates as designed during and after exposure to a disturbance.

Kind	Immunity to Conducted Disturbances, Induced by RF-Fields
According	DIN EN 61000-4-6:2001-12
Check accuracy / Limit	10 Vrms; 150 kHz - 80 MHz; AM; m = 0,8; f = 1 kHz; 1%; t = 3 s
Result	A: The monitored function operates as designed during and after exposure to a disturbance.

5 Safety**5.1 Electrical Safety**

Dielectric strength DIN EN 62368 and DIN EN 60335 A.) Type test Measuring conditions: After 48h of storage at 95% R.H. and 25°C. No arcing or breakdown is allowed! All connections together to ground. B.) Routine test Measuring conditions: At indoor climate. No arcing or breakdown is allowed! All connections together to ground.	500 VAC / 1 Min. 850 VDC / 1 Sec.	
Isolation resistance Measuring conditions: After 48h of storage at 95% R.H. and 25°C measured with U=500 VDC for 1 min.	RI > 10 MOhm	
Clearance / creepage distance	1,0 mm / 1,2 mm	
Protection class	III	

5.2 Approval Tests

CE	EC Declaration of Conformity	Yes
EAC	Eurasian Conformity	Yes
UL	Underwriters Laboratories	Yes / UL507, Electric Fans E38324
VDE	Association for Electrical, Electronic and Information Technologies	Yes / Approval acc. to EN 62368 - Audio/video, information and communication technology equipment
CSA	Canadian Standards Association	Yes / C22.2 No. 113 Fans and Ventilators
CCC	China Compulsory Certification	Not applicable

The approval tests are observed to:

U approval max.: 26,4 V @ TU approval max.: 70,0 °C

6 Reliability**6.1 General**

Life expectancy L10 at TU = 40 °C	60.000 h	
Life expectancy L10 at TU max.	30.000 h	
Life expectancy L10 acc. to IPC 9591 at TU = 40 °C	102.500 h	

The reproduction, distribution and utilization of this document as well as the communication of its contents to others without express authorization is prohibited. Offenders will be held liable for the payment of damages. All rights reserved in the event of the grant of a patent, utility model or design. Refer to protection notices ISO 16061. Note: in case of multilingual information in this document and in the applicable documents referred to in this document, only the English version shall be authoritative and legally binding in the event of contradictions in content.

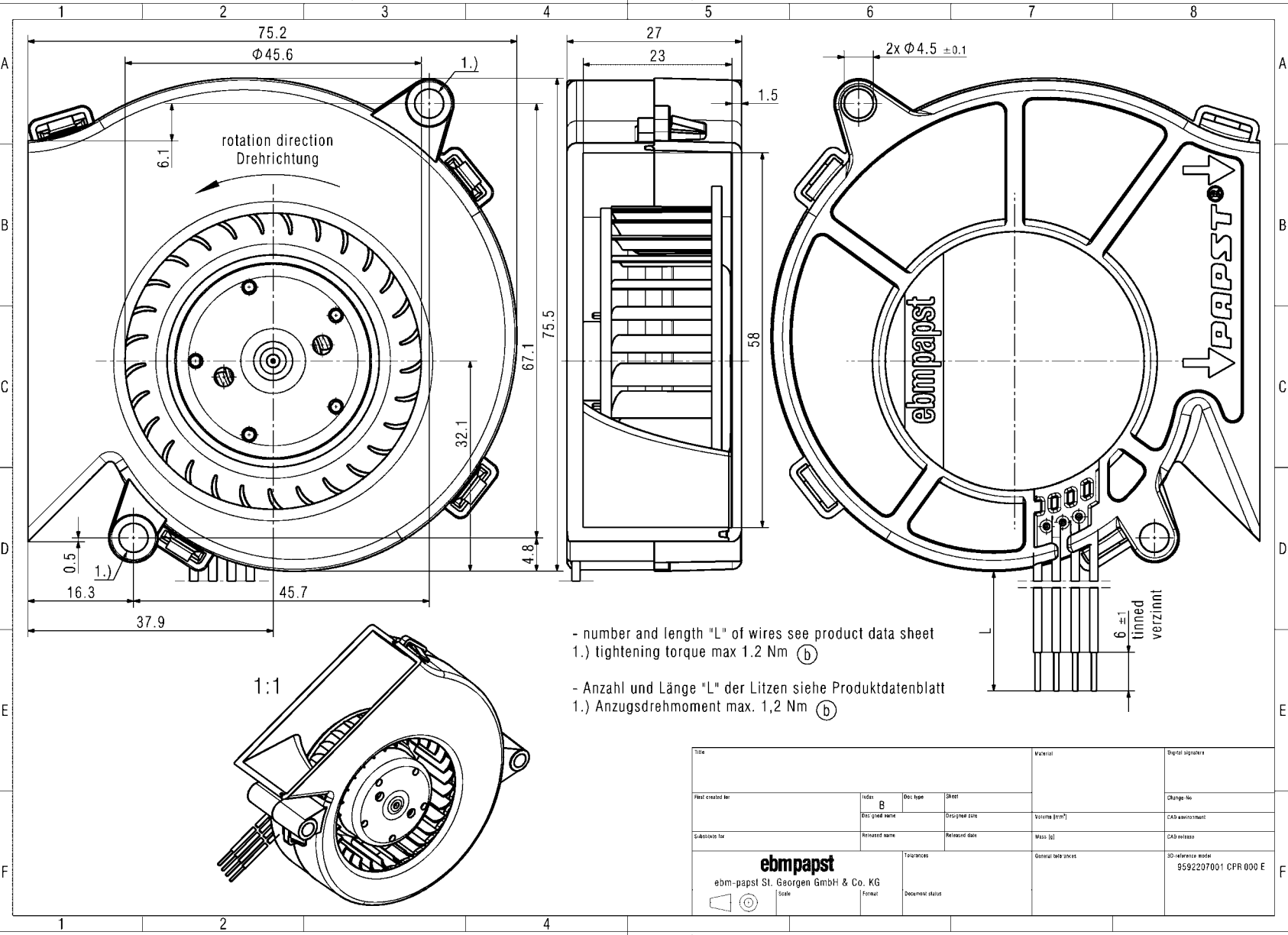

- number and length "L" of wires see product data sheet
- 1.) tightening torque max 1.2 Nm (b)
- Anzahl und Länge "L" der Litzen siehe Produktdatenblatt
- 1.) Anzugsdrehmoment max. 1,2 Nm (b)

Title				Material	Digital signature
Part created for	Index	Doc. type	Sheet	Change No.	
	B				
Doc. grid name	Released name	Design date	Volume [l/cm³]	CAD environment	
Substrate for	Released date		Mass [g]	CAD release	
ebmpapst ebm-papst St. Georgen GmbH & Co. KG Scale			Tolerances	General tab sheet	3D-reference model 9592207001 CPR 000 E
		Format	Document status		