

**Product Data Sheet**    **9595414378**  
VCS0160XULCS  
RG160-28/18N/2TDA

**ebmpapst**

The engineer's choice

RG160-28/18N/2TDA (9595414378) ebmpapst Datasheet FansCo  
sales@fansco.com  
www.fansco.com



RG160-28/18N/2TDA (9595414378) ebmpapst Datasheet FansCo sales@fansco.com www.fansco.com



RG160-28/18N/2TDA

INDEX

1 General ..... 3

2 Mechanics ..... 3

    2.1 General..... 3

    2.2 Connections..... 3

3 Operating Data ..... 4

    3.1 Electrical Interface - Input..... 4

    3.2 Electrical Operating Data ..... 5

    3.3 Electrical Interface - Output..... 8

    3.4 Electrical Features ..... 9

    3.5 Aerodynamics ..... 10

    3.6 Sound Data..... 11

4 Environment..... 11

    4.1 General..... 11

    4.2 Climatic Requirements ..... 11

5 Safety..... 12

    5.1 Electrical Safety ..... 12

    5.2 Approval Tests ..... 12

6 Reliability..... 12

    6.1 General..... 12

1 General

Fan type	Blower	
Rotating direction looking at rotor	Counterclockwise	
Airflow direction	Air in axially, Air out radially	
Bearing system	Ball bearing	
Mounting position - shaft	Any	

2 Mechanics

2.1 General

Width	220,0 mm	
Height	220,0 mm	
Depth	56,0 mm	
Mass	1,400 kg	
Housing material	Mixed	
Impeller material	Plastic	
Max. torque when mounted across both mounting flanges; Metal flange on mounting plate	Wire outlet corner: 70 Ncm Remaining corners: 70 Ncm	
Screw size	ISO 4762 - M4 degreased, without an additional brace and without washer	

2.2 Connections

Electrical connection	Wires	
Lead wire length	L = 325 mm	
Tolerance	+ - 10,0 mm	
Tube length	S = 25 mm	
Tolerance	+ - 5,0 mm	

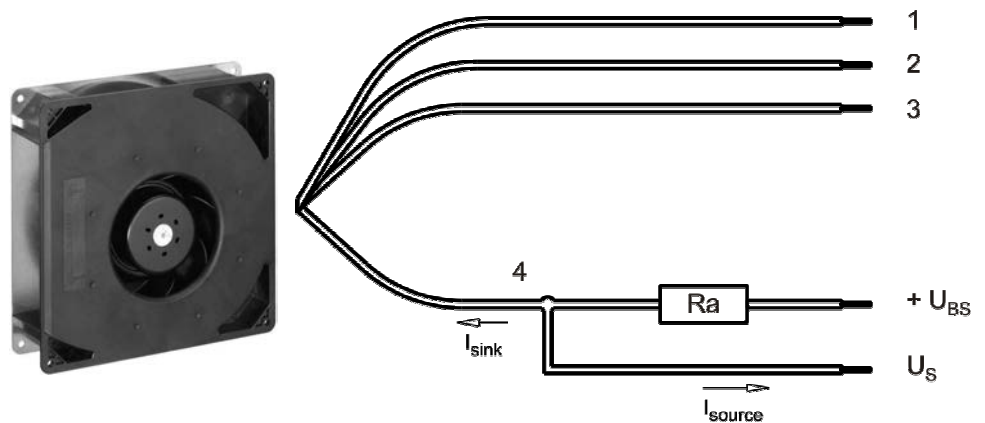

Wire	Color	Operation	Wire size	Insulation diameter
1	red	+ UB	AWG 22	1,70 mm
2	blue	- GND	AWG 22	1,70 mm
3	violet	CONTR	AWG 22	1,70 mm
4	white	Tacho	AWG 22	1,70 mm

The auxiliaries shown on the schematic diagram (which are required for the intended use) are not part of our delivery.

3 Operating Data

3.1 Electrical Interface - Input

Control input	Analog
---------------	--------

Features

Input voltage range	0 V - 10 V
---------------------	------------

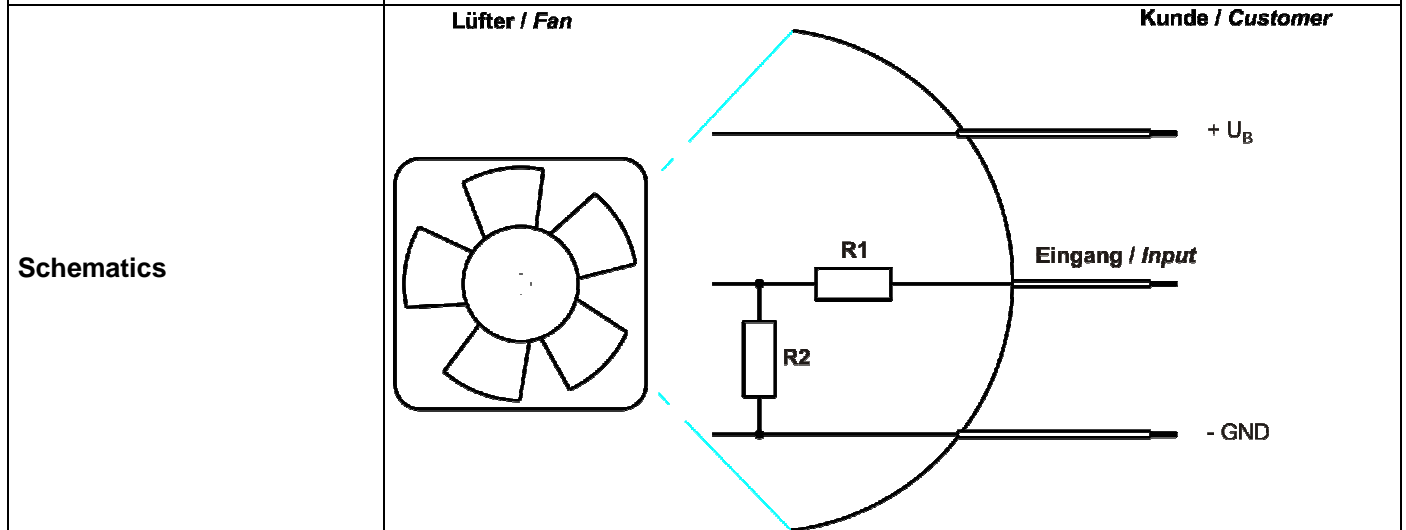
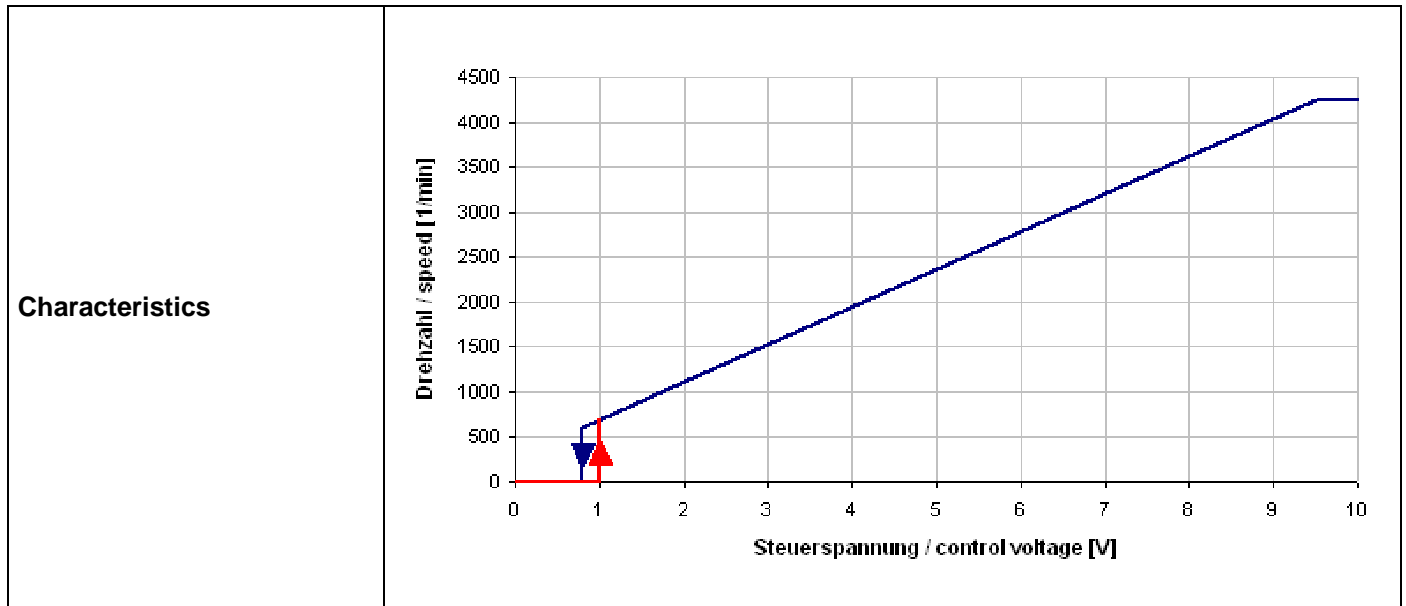

**Speed control:**

By control voltage.

U Contr.: 0... 10 V +-0,1 V

### 3.2 Electrical Operating Data

Measurement conditions: Normal air density = 1,2 kg/m<sup>3</sup>; Temperature 23°C +/- 3°C; Motor axis horizontal; warm-up time before measuring 5 minutes (unless otherwise specified). In the intake and outlet area should not be any solid obstruction within 0,5 m.

$\Delta p = 0$ : corresp. to free air flow (see chapter aerodynamics)  
I: corresp. to arithm. mean current value

Name	Condition
U Contr. 0001	U Contr.: 10 V

Features	Condition	Symbol	Values		
Voltage range		U	36 V		60 V
Nominal voltage		$U_N$		48 V	
Power consumption	$\Delta p = 0$	P	35 W	65 W	61 W
Tolerance	U Contr. 0010		+/- 15 %	+/- 15,0 %	+/- 15,0 %
Current consumption	$\Delta p = 0$	I	1.000 mA	1.350 mA	1.000 mA
Tolerance	U Contr. 0010		+/- 15,0 %	+/- 15,0 %	+/- 15,0 %
Speed	$\Delta p = 0$	n	3.500 1/min	4.250 1/min	4.250 1/min
Tolerance	U Contr. 0010		+/- 7,5 %	+/- 7,5 %	+/- 7,5 %

#### Motor testing

The motor testing relates to a fan, operating with horizontal shaft, at free air flow. It is possible to run this motor in an uncontrolled state. For some testings the motor may set in a test cycle by connecting to a voltage follower as below mentioned.

#### Voltage graph to start the test cycle

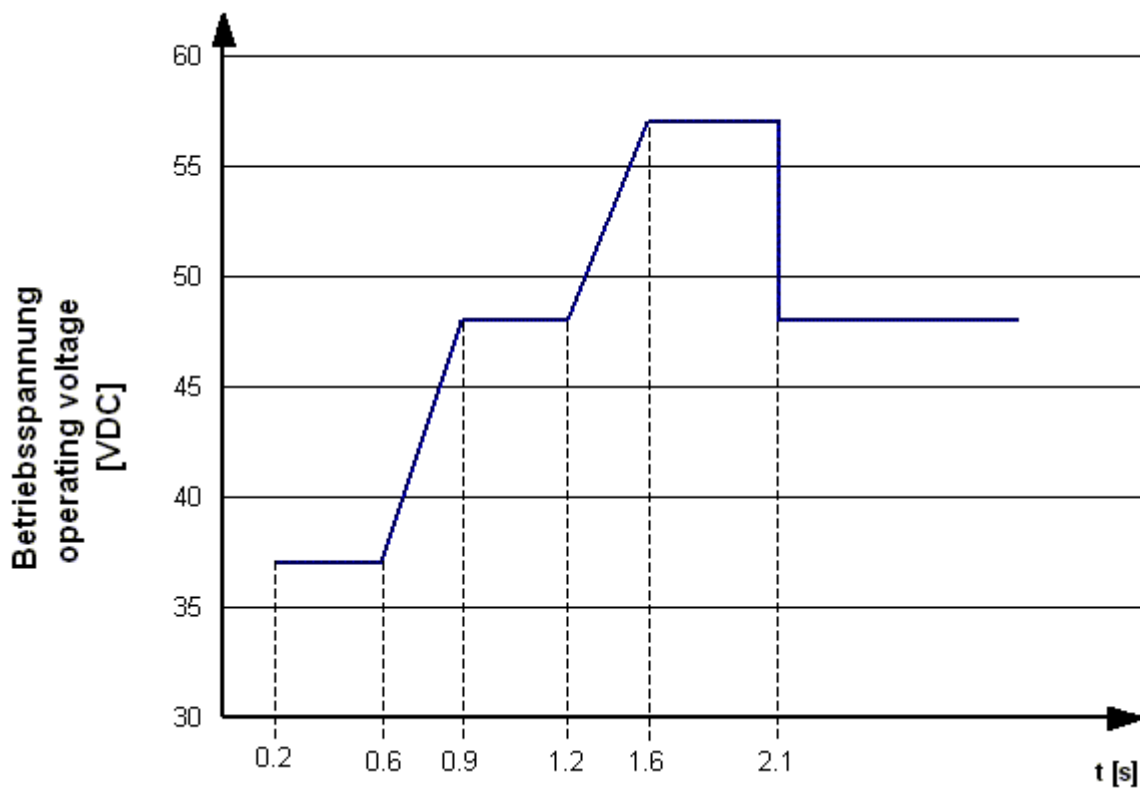

Speed graph after starting the test cycle

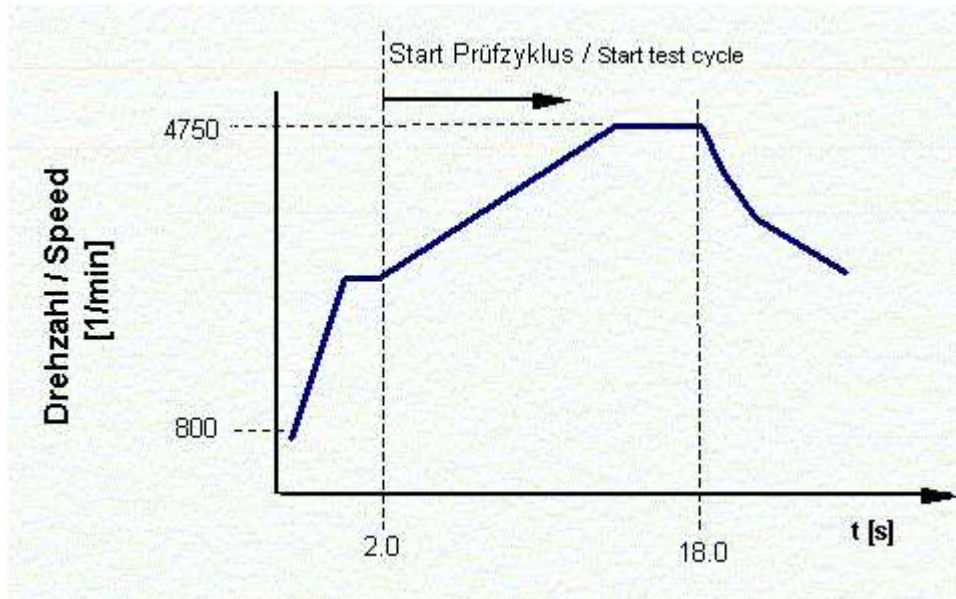

Voltage	48,0 V
Power consumption	52,8 W
Tolerance	+ - 15,0 %
Current consumption	1.100 mA
Tolerance	+ - 15,0 %
Speed	4.750 1/min
Tolerance	+ - 10,0 %

3.3 Electrical Interface - Output

Tacho type	/2 (open collector)
------------	---------------------

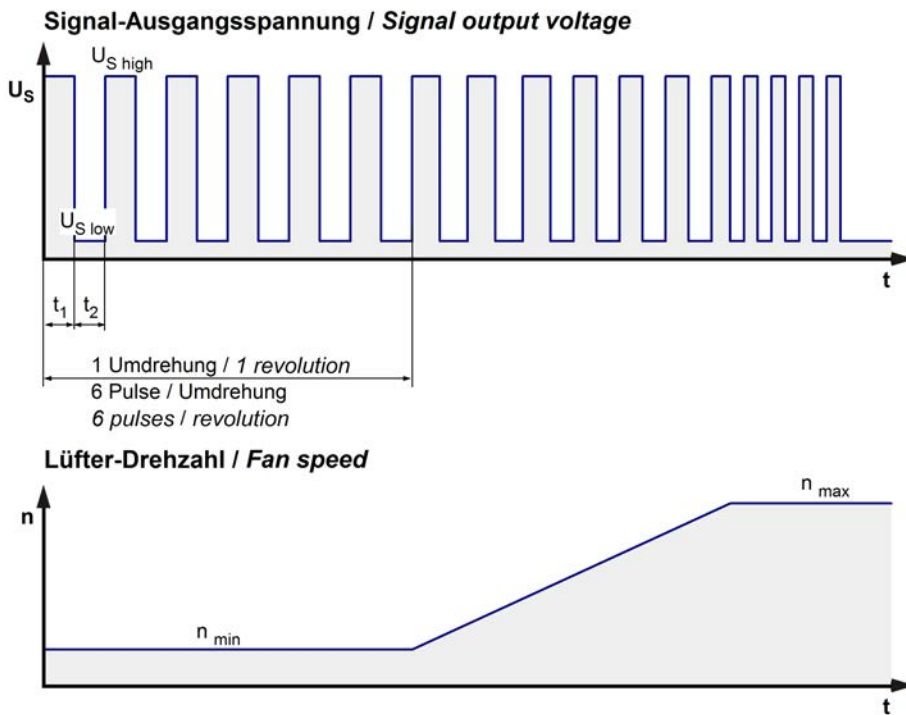

$$R_a = \frac{U_{BS} - U_{S\ low}}{I_{sink}}$$

Lüfter / Fan      Kunde / Customer

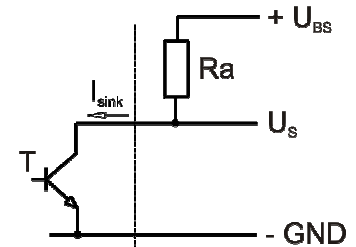

Features	Note	Values
Tacho operating voltage	$U_{BS}$	$\leq 60,0\ V$
Tacho signal Low	$U_{S\ low}$	$\leq 0,4\ V$
Tacho signal High	$U_{S\ high}$	$60,0\ V$
Maximum sink current	$I_{sink}$	$\leq 20\ mA$
External resistor	External resistor $R_a$ from $U_{BS}$ to $U_S$ required. All voltages measured to GND.	
Tacho frequency	$(6 \times n) / 60$	
Tacho isolated from motor	No	
Slew rate		$\Rightarrow 0,5\ V/\mu s$

n = revolutions per minute (1/min)

3.4 Electrical Features

Electronic function	Speed-Controlled	
Reversed polarity protection	Rectifying diode	
Max. residual current at $U_N$	$I_F \leq 20 \text{ mA}$	
Locked rotor protection	Auto restart	
Locked rotor current at $U_N$	$I_{\text{block}}$ approx. 200 mA	
Clock signal at locked rotor	$t_3 / t_4$ typical: 1,0 s / 3,1 s	

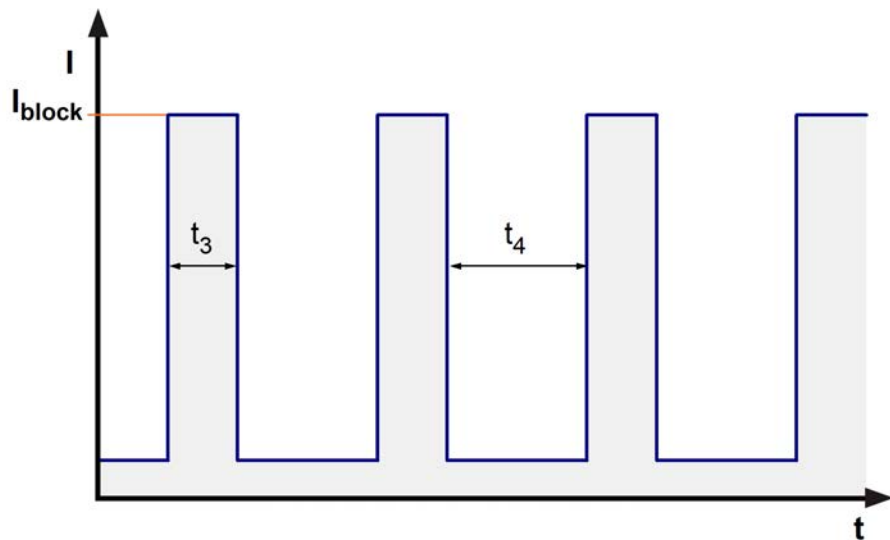

3.5 Aerodynamics

Measurement conditions: Measured with a double chamber intake rig acc. to DIN EN ISO 5801.  
Normal air density = 1,2 kg/m<sup>3</sup>; Temperature 23°C +/- 3°C;  
In the intake and outlet area should not be any solid obstruction within 0,5 m. Motor shaft horizontal.  
The information is only valid under the specified test conditions and may be changed by the installation conditions. If there are deviations from the standard test conditions, the characteristic values must be checked under the installed conditions.

a.) Operation condition:

4.250 1/min at free air flow	U Contr. 10 V		
Max. free-air flow ( $\Delta p = 0 / \dot{V} = \text{max.}$ )		310,0 m <sup>3</sup> /h	
Max. static pressure ( $\Delta p = \text{max.} / \dot{V} = 0$ )		810 Pa	

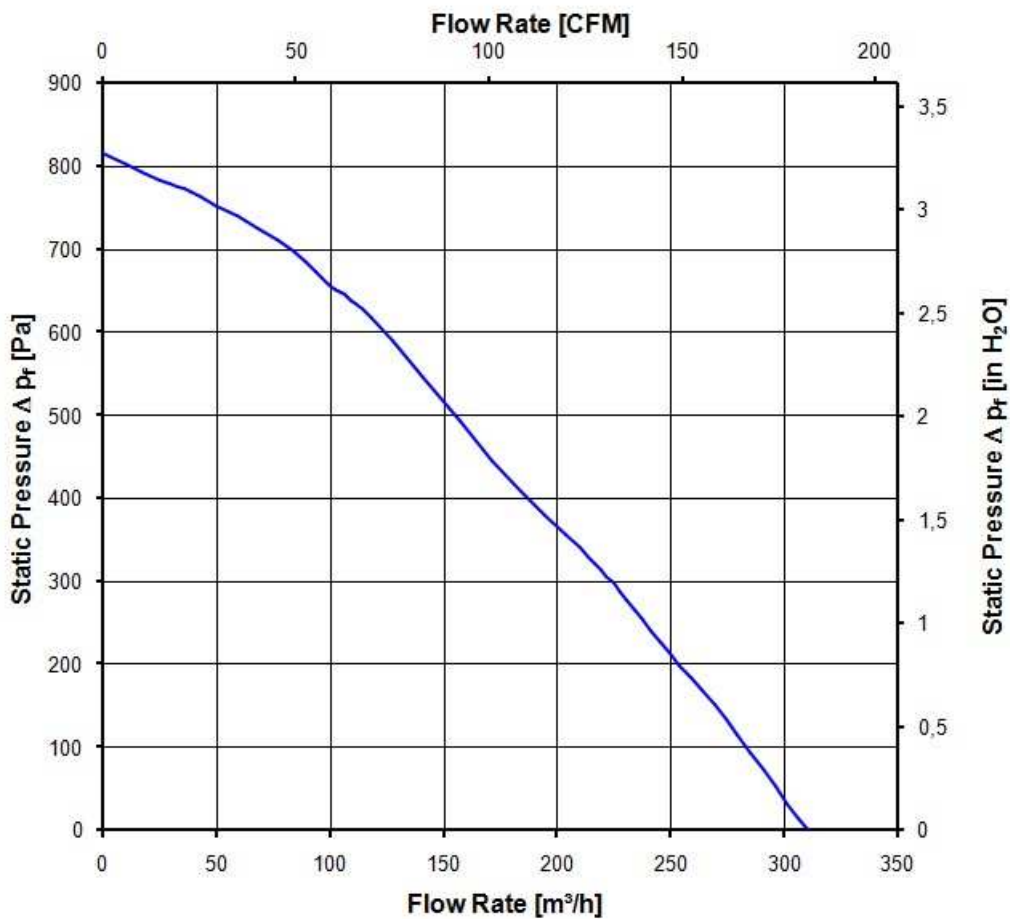

### 3.6 Sound Data

Measurement conditions: Sound pressure level: 1 meter distance between microphone and the air intake.  
Sound power level: Acc. to DIN 45635 part 38 (ISO 10302)  
Measured in a semianchoic chamber with a background noise level of  $L_p(A) < 5 \text{ dB(A)}$   
For further measurement conditions see chapter aerodynamics.

a.) Operation condition:

4.250 1/min at free air flow	U Contr. 10 V		
------------------------------	---------------	--	--

Optimal operating point	188,0 m <sup>3</sup> /h @ 356 Pa	
Sound power level at the optimal operating point	7,5 bel(A)	
Sound pressure level at free air flow, measured in rubber bands		

## 4 Environment

### 4.1 General

Min. permitted ambient temperature TU min.	-20 °C	
Max. permitted ambient temperature TU max.	60 °C	
Min. permitted storage temperature TL min.	-40 °C	
Max. permitted storage temperature TL max.	80 °C	

### 4.2 Climatic Requirements

Humidity requirements	humid heat, constant; according to DIN EN 60068-2-78, 14 days	
Water exposure	None	
Dust requirements	None	
Salt fog requirements	None	

Permitted application area:

The product is intended for use in sheltered rooms with controlled temperature and controlled humidity. Directly exposure to water must be avoided.

Pollution degree 1 (according DIN EN 60664-1)

There is either no pollution or it occurs only dry, non-conductive pollution. The pollution has no negative impact.

Please require severity levels and specification parameters from the responsible development departments.

## 5 Safety

### 5.1 Electrical Safety

Dielectric strength DIN EN 60950 (VDE 0805) and DIN EN 60335 (VDE 0700) A.) Type test Measuring conditions: After 48h of storage at 95% R.H. and 25°C. No arcing or breakdown is allowed! All connections together to ground.	500 VAC / 1 Min.	
B.) Routine test Measuring conditions: At indoor climate. No arcing or breakdown is allowed! All connections together to ground.	850 VDC / 1 Sec.	
Isolation resistance Measuring conditions: After 48h of storage at 95% R.H. and 25°C measured with U=500 VDC for 1 min.	RI > 10 MOhm	
Clearance / creepage distance	1,0 mm / 1,5 mm	
Protection class	III	

### 5.2 Approval Tests

CE	EC Declaration of Conformity	Yes
EAC	Eurasian Conformity	Yes
UL	Underwriters Laboratories	Yes / UL507, Electric Fans E38324
VDE	Association for Electrical, Electronic and Information Technologies	Yes / Approval acc. to EN 60950 (VDE 0805) - Information technology equipment
CSA	Canadian Standards Association	Yes / C22.2 No. 113 Fans and Ventilators
CCC	China Compulsory Certification	Yes / GB 12350 Safety Requirements for small Power Motors

## 6 Reliability

### 6.1 General

Life expectancy L10 at TU = 40 °C	55.000 h	
Life expectancy L10 at TU max.	27.500 h	
Life expectancy L10 acc. to IPC 9591 at TU = 40 °C	92.5 00 h	

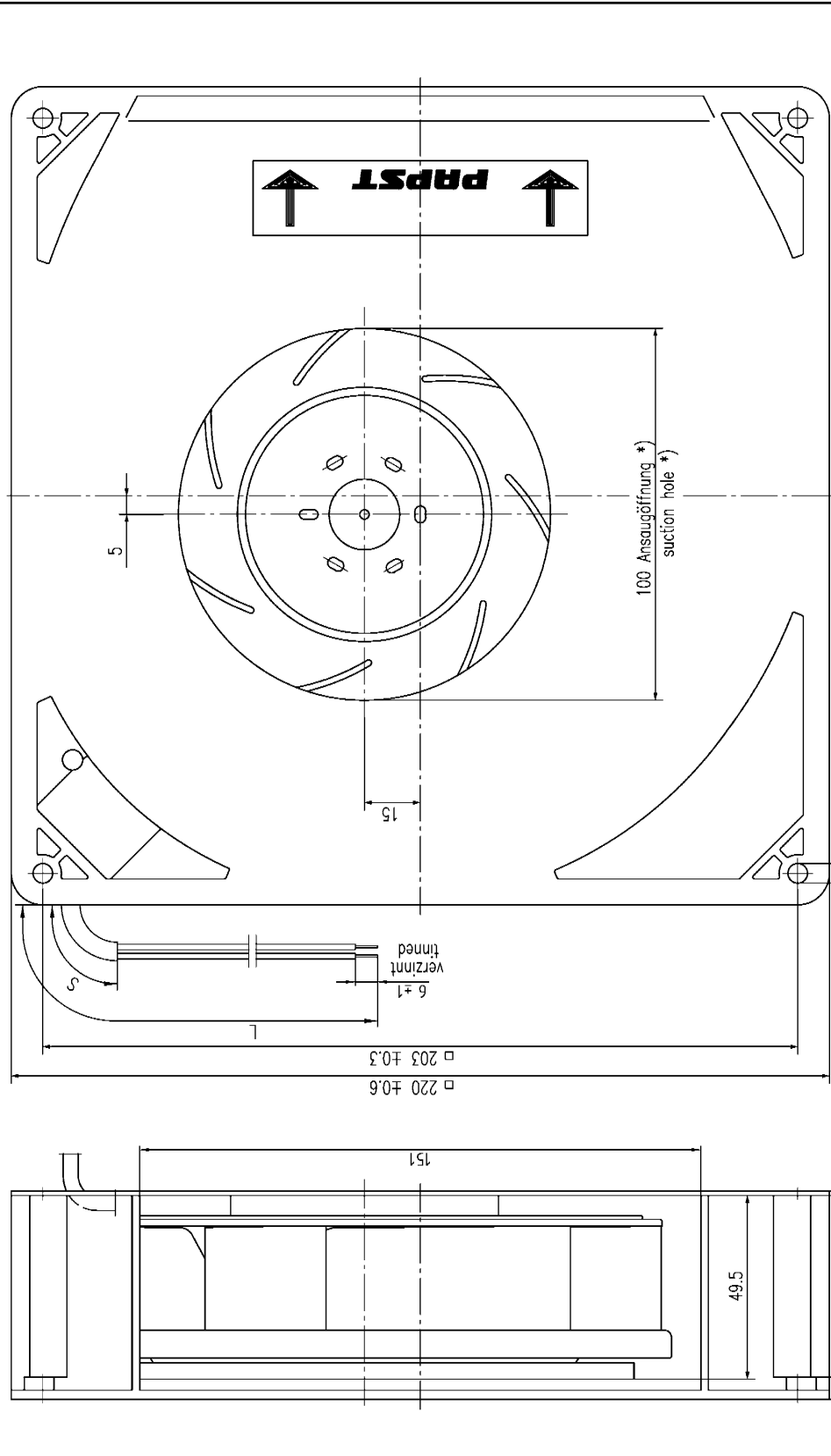

Tolerierung/Tolerances: Allgemeintoleranz/Gen. tolerances:		DIN ISO 2768-mS-E		Art./Item/Title	
Bezeichnung/Design	Name/Name	DIN ISO 2768-mS-E		Messstab/Scale	
Hersteller/Manufacturer	Vertrieb/Trade Name	ebmpapst		Blatt/Page	
Zug-Nr./Drawing No.:		ebmpapst St. Georgen GmbH & Co. KG		Ers./Zug./Replaces:	
Ers./Zug./Replaces:		ebmpapst St. Georgen GmbH & Co. KG		A3	

Axialspiel: mit Feder spielfrei verspannt.  
 without axial clearance by a pre-loaded spring  
 \*) Öffnung f. Montagewand  $\approx 115$   
 \*) Opening for mounting plate  $\approx 115$

Anzahl und Länge der Litzen  
 sowie Länge Schlauch siehe BV Bl. 1  
 Length and number of wires and length  
 of tube see design specification page 1

Copying of this document and giving it to others and the use or communication of the contents thereof are  
 forbidden without express authority. Offenders are liable to the payment of damages. All rights are reserved.  
 Schutzrecht nach DIN ISO 9016 beachteten  
 Refer to protection notice DIN ISO 9016