

Product Data Sheet **9595420062**
VBS0133XULDS
RER133-41/14/2TDP

RER133-41/14/2TDP (9595420062) ebmpapst Datasheet
sales@fansco.com www.fansco.com

ebmpapst

engineering a better life



RER133-41/14/2TDP

INDEX

- 1 General 3**
- 2 Mechanics 3**
 - 2.1 General 3
 - 2.2 Connections 3
- 3 Operating Data 5**
 - 3.1 Electrical Interface - Input 5
 - 3.2 Electrical Operating Data 6
 - 3.3 Electrical Interface - Output 7
 - 3.4 Electrical Features 8
 - 3.5 Aerodynamics 9
 - 3.6 Sound Data 10
- 4 Environment 10**
 - 4.1 General 10
 - 4.2 Climatic Requirements 10
- 5 Safety 11**
 - 5.1 Electrical Safety 11
 - 5.2 Approval Tests 11
- 6 Reliability 11**
 - 6.1 General 11

1 General

Fan type	Blower without chassis with intake nozzle	
Rotating direction looking at rotor	Clockwise	
Airflow direction	Air in axially, Air out radially	
Bearing system	Ball bearing	
Mounting position - shaft	Any	

Please note:

"Sensorless commutation electronic, starting at the first start may not be 100% guaranteed, automatic restart occurs."

2 Mechanics

2.1 General

Depth	91,0 mm	
Diameter	133,0 mm	
Mass	0,890 kg	
Housing material		
Impeller material	Plastic	

2.2 Connections

Electrical connection	Wires	
Lead wire length	L = 425 mm	
Tolerance	+/- 10,0 mm	
Tube length	S = 115 mm	
Tolerance	+/- 5,0 mm	
Wire size (AWG)	20	
Insulation diameter	2,05 mm	

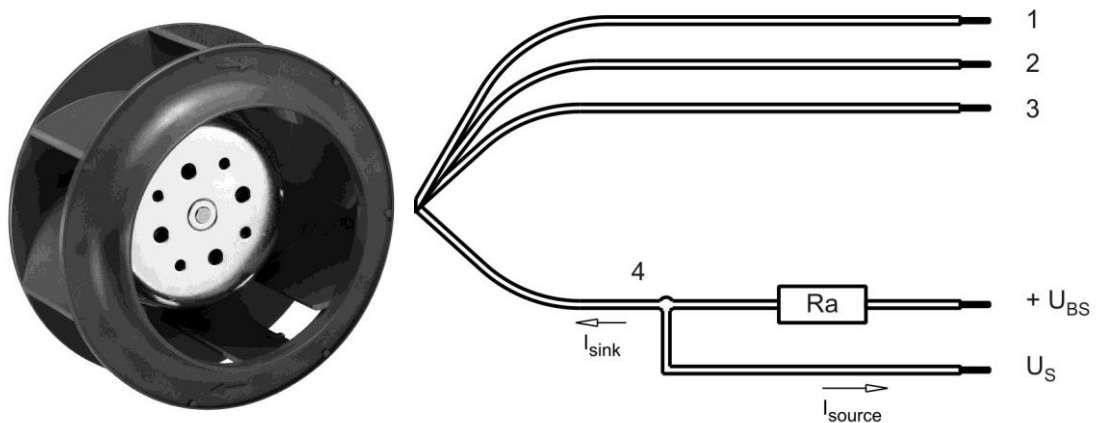

Wire	Color	Operation
1	red	+ UB
2	blue	- GND
3	violet	PWM
4	white	Tacho

The auxiliaries shown on the schematic diagram (which are required for the intended use) are not part of our delivery.

Litzen 1 - 2: AWG20 (Isolationsdurchmesser 2,05mm)
Litzen 3 - 4: AWG22 (Isolationsdurchmesser 1,35mm)

Lead wire 1 - 2: AWG20 (Insulation diameter 2,05mm)
Lead wire 3 - 4: AWG22 (Insulation diameter 1,35mm)

3 Operating Data

3.1 Electrical Interface - Input

Control input	PWM
---------------	-----

Features

Input type	Open collector	
PWM - Frequency		1 kHz - 10 kHz typical: 2 kHz

<p>Characteristics</p>	
<p>Schematics</p>	

Speed control:
 By Puls-width-modulation (PWM) 0 ... 100%
 Open collector in relation to Signalground
 f = 2kHz +-20%

Information to the curve:

0 % - 7% PWM:	0 1/min
7 % PWM:	800 1/min (Fan on, coming from 0% PWM)
7 % - 10% PWM:	800 1/min (corresponding to min. speed)
10 % - 90% PWM:	linear increasing curve
90 % - 100% PWM:	6.000 1/min (corresponding to max. speed)
7 % - 5 % PWM:	linear decreasing curve (coming from 100% PWM)
5 % PWM:	600 1/min or 0 1/min (Fan off, coming from 100% PWM)

3.2 Electrical Operating Data

Measurement conditions: Normal air density = 1,2 kg/m³; Temperature 23°C +/- 3°C; Motor axis horizontal; warm-up time before measuring 5 minutes (unless otherwise specified).
In the intake and outlet area should not be any solid obstruction within 0,5 m.

Measurement setup:	Measured between two steel plates
Steel plate:	140 mm x 140 mm
Intake nozzle:	D: 87 mm; R: 7 mm
Distance between bottom and top plate:	101 mm
Overlapping impeller / nozzle:	2 mm

$\Delta p = 0$: corresp. to free air flow (see chapter aerodynamics)
I: corresp. to arithm. mean current value

Name	Condition
PWM 0001	PWM: 100 %; f: 2 kHz

100% PWM; f = 2 kHz or broken lead wire (open control input)

Features	Condition	Symbol	Values		
Voltage range		U	16 V		36 V
Nominal voltage		U _N		24 V	
Power consumption	$\Delta p = 0$	P	46 W	94 W	94 W
Tolerance	PWM 0010		+/- 10 %	+/- 10 %	+/- 10 %
Current consumption	$\Delta p = 0$	I	2.900 mA	3.900 mA	2.600 mA
Tolerance	PWM0010		+/- 10 %	+/- 10 %	+/- 10 %
Speed	$\Delta p = 0$	n	4.730 1/min	6.000 1/min	6.000 1/min
Tolerance	PWM 0010		+/- 7,5 %	+/- 5 %	+/- 5 %

3.3 Electrical Interface - Output

Tacho type	/2 (open collector)
------------	---------------------

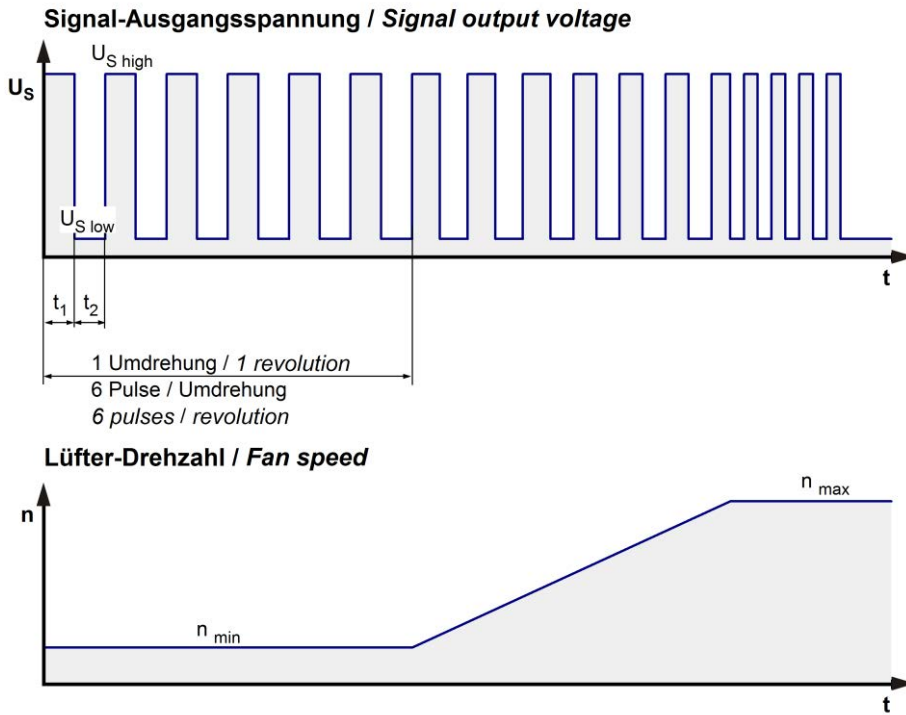

$$R_a = \frac{U_{BS} - U_{S\ low}}{I_{sink}}$$

Lüfter / Fan Kunde / Customer

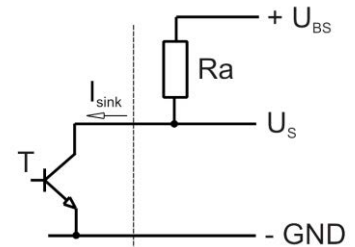

Features	Note	Values
Tacho operating voltage	U_{BS}	$\leq 60\ V$
Tacho signal Low	$U_{S\ low}$	$\leq 0,4\ V$
Tacho signal High	$U_{S\ high}$	$\leq 60,0\ V$
Maximum sink current	I_{sink}	$\leq 20\ mA$
Maximum source current		$0\ mA$
External resistor	External resistor R_a from U_{BS} to U_S required. All voltages measured to GND.	
Tacho frequency	$(6 \times n) / 60$	600 Hz
Tacho isolated from motor	No	
Slew rate		$\Rightarrow 0,5\ V/\mu s$

n = revolutions per minute (1/min)

Please note:

At zero speed the tacho signal is at a static HIGH. It will be also HIGH when the fan is still spinning, but the speed control signal is set to zero speed already.

The tacho signal is only activated after the start-up is completed.

3.4 Electrical Features

Electronic function	Speed-Controlled	
Reversed polarity protection	P-CH FET	
Max. residual current at U_N	$I_F \leq 5 \text{ mA}$	
Locked rotor protection	Auto restart	
Locked rotor current at U_N	I_{block} approx. 1.300 mA	
Lock signal at locked rotor	t_3 / t_4 typical: 5,5 s / 10,0 s	

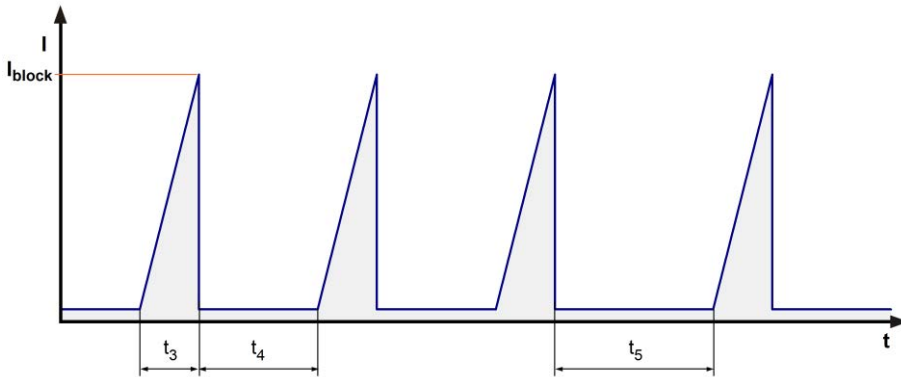

Locked rotor signal t5:

After 4 failed start-ups there is an extended timeout of 40 s.

3.5 Aerodynamics

Measurement conditions: Measured with a double chamber intake rig acc. to DIN EN ISO 5801. Normal air density = 1,2 kg/m³; Temperature 23°C +/- 3°C; In the intake and outlet area should not be any solid obstruction within 0,5 m. Motor shaft horizontal.

The information is only valid under the specified test conditions and may be changed by the installation conditions. If there are deviations from the standard test conditions, the characteristic values must be checked under the installed conditions. Power consumption of the fan motor when operating at normal voltage is shown. Depending on the operating conditions of the application, the power input may be higher.

Measurement setup:	Measured between two steel plates
Steel plate:	140 mm x 140 mm
Intake nozzle:	D: 87 mm; R: 7 mm
Distance between bottom and top plate:	101 mm
Overlapping impeller / nozzle:	2 mm

a.) Operation condition:

6.000 1/min at free air flow	PWM 100 %; f: 2 kHz		
------------------------------	---------------------	--	--

Max. free-air flow ($\Delta p = 0 / \dot{V} = \text{max.}$)	540 m ³ /h	
Max. static pressure ($\Delta p = \text{max.} / \dot{V} = 0$)	745 Pa	

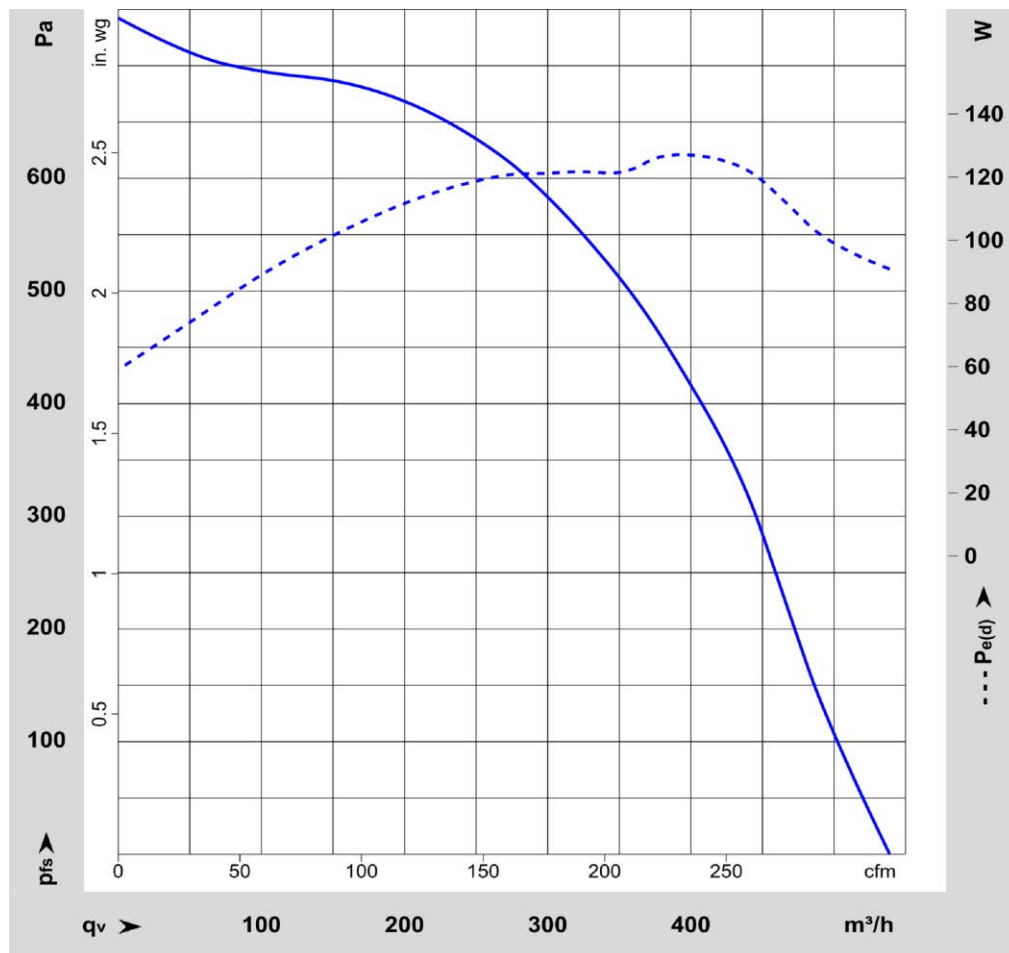

3.6 Sound Data

Measurement conditions: Sound pressure level: 1 meter distance between microphone and the air intake.
Sound power level: According to ISO 13347-3.
Measured in a semianechoic chamber with a background noise level of $L_p(A) < 5 \text{ dB(A)}$
For further measurement conditions see chapter aerodynamics.

a.) Operation condition:

6.000 1/min at free air flow	PWM 100 %; f: 2 kHz		
------------------------------	---------------------	--	--

Optimal operating point	315 m ³ /h @ 565 Pa	
Sound power level at the optimal operating point	8,2 bel(A)	
Sound pressure level at free air flow, measured in rubber bands		

4 Environment

4.1 General

Min. permitted ambient temperature TU min.	-20 °C	
Max. permitted ambient temperature TU max.	65 °C	
Min. permitted storage temperature TL min.	-40 °C	
Max. permitted storage temperature TL max.	80 °C	

4.2 Climatic Requirements

Humidity requirements	humid heat, constant; according to DIN EN 60068-2-78, 14 days	
Water exposure	None	
Dust requirements	None	
Salt fog requirements	None	

Permitted application area:

The product is intended for use in sheltered rooms with controlled temperature and controlled humidity. Directly exposure to water must be avoided.

Pollution degree 1 (according DIN EN 60664-1)

There is either no pollution or it occurs only dry, non-conductive pollution. The pollution has no negative impact.

Please require severity levels and specification parameters from the responsible development departments.

5 Safety**5.1 Electrical Safety**

Dielectric strength DIN EN 62368 and DIN EN 60335 A.) Type test Measuring conditions: After 48h of storage at 95% R.H. and 25°C. No arcing or breakdown is allowed! All connections together to ground.	500 VAC / 1 Min.	
B.) Routine test Measuring conditions: At indoor climate. No arcing or breakdown is allowed! All connections together to ground.	850 VDC / 1 Sec.	
Isolation resistance Measuring conditions: After 48h of storage at 95% R.H. and 25°C measured with U=500 VDC for 1 min.	RI > 10 MOhm	
Clearance / creepage distance	1,0 mm / 1,2 mm	
Protection class	III	

5.2 Approval Tests

CE	EC Declaration of Conformity	Yes
EAC	Eurasian Conformity	Yes
UL	Underwriters Laboratories	Yes / UL507, Electric Fans E38324
VDE	Association for Electrical, Electronic and Information Technologies	Yes / Approval acc. to EN 62368 - Audio/video, information and communication technology equipment
CSA	Canadian Standards Association	Yes / C22.2 No. 113 Fans and Ventilators
CCC	China Compulsory Certification	Not applicable

6 Reliability**6.1 General**

Life expectancy L10 at TU = 40 °C	70.000 h	
Life expectancy L10 at TU max.	37.500 h	
Life expectancy L10 acc. to IPC 9591 at TU = 40 °C	117.500 h	

CACCIA® è un marchio registrato di CACCIA S.p.A. e non può essere utilizzato senza permesso scritto dalla CACCIA S.p.A. per scopi non autorizzati. CACCIA S.p.A. non è responsabile per danni derivanti dall'uso non autorizzato del prodotto.

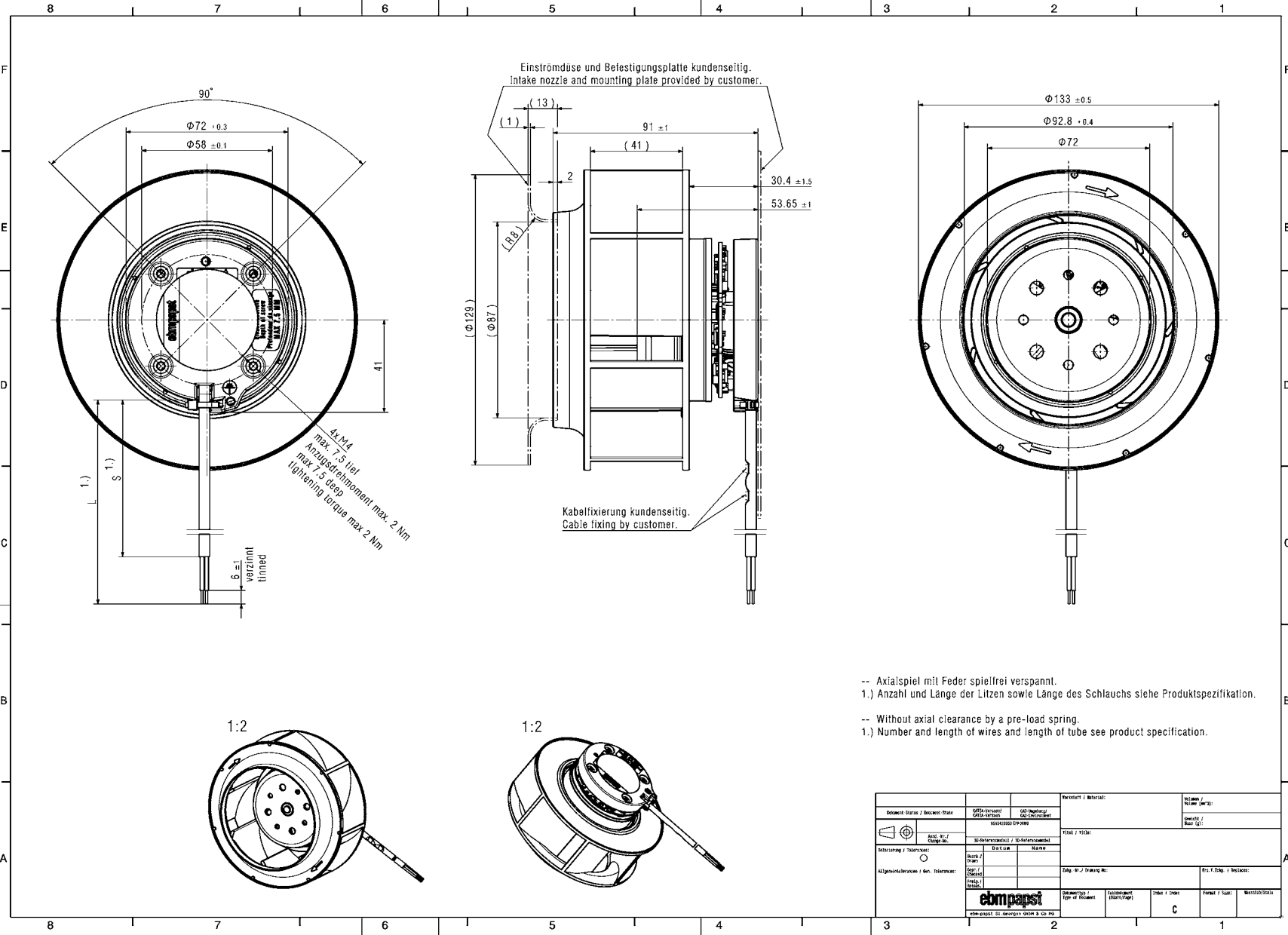

-- Axialspiel mit Feder spielfrei verspannt.
 1.) Anzahl und Länge der Litzen sowie Länge des Schlauchs siehe Produktspezifikation.

-- Without axial clearance by a pre-load spring.
 1.) Number and length of wires and length of tube see product specification.

Datasheet Status / Document State (G) Approved / (G) In Review (S) Suspended / (P) Open		Revision / Version: Revision / Version: Date / Date:	
Zeichnung / Drawing: Name: Date / Date: Part / Part: Material / Material:		Title / Title: Date / Drawing No.: Rev. / Date / Revision:	
ebmpapst ebmpapst St. Georgen GmbH & Co. KG		Drawing No. / Zeichnungs-Nr.: C	Part No. / Teil-Nr.: W101003001