

**Product Data Sheet**    **9793520190**  
VBS0101XUGDS  
RER101-36/14NHH

RER101-36/14NHH (9793520190) ebmpapst Datasheet sales@fansco.com www.fansco.com

**ebmpapst**

engineering a better life



RER101-36/14NHH (9793520190) ebmpapst Datasheet sales@fansco.com www.fansco.com

RER101-36/14NHH

INDEX

**1 General ..... 3**

**2 Mechanics ..... 3**

2.1 General ..... 3

2.2 Connections ..... 3

**3 Operating Data ..... 4**

3.1 Electrical Operating Data ..... 4

3.2 Electrical Features ..... 5

3.3 Aerodynamics ..... 6

3.4 Sound Data ..... 7

**4 Environment ..... 7**

4.1 General ..... 7

4.2 Climatic Requirements ..... 7

**5 Safety ..... 8**

5.1 Electrical Safety ..... 8

5.2 Approval Tests ..... 8

**6 Reliability ..... 8**

6.1 General ..... 8

**1 General**

Fan type	Blower without chassis with intake nozzle	
Rotating direction looking at rotor	Clockwise	
Airflow direction	Air in axially, Air out radially	
Bearing system	Ball bearing	
Mounting position - shaft	Any	

**2 Mechanics**

**2.1 General**

Depth	36,0 mm	
Diameter	101,0 mm	
Mass	0,300 kg	
Housing material		
Impeller material	Plastic	

**2.2 Connections**

Electrical connection	Wires	
Lead wire length	L = 310 mm	
Tolerance	+/- 10,0 mm	

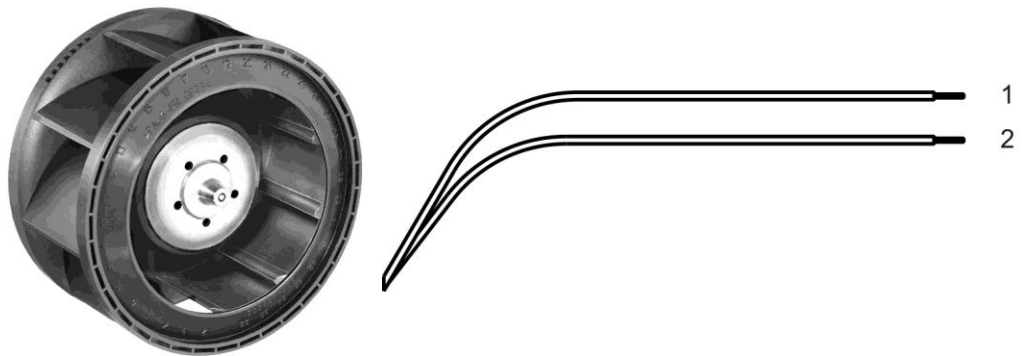

Wire	Color	Operation	Wire size	Insulation diameter
1	red	+ UB	AWG 22	1,70 mm
2	blue	- GND	AWG 22	1,70 mm

### 3 Operating Data

#### 3.1 Electrical Operating Data

Measurement conditions: Normal air density = 1,2 kg/m<sup>3</sup>; Temperature 23°C +/- 3°C; Motor axis horizontal; warm-up time before measuring 5 minutes.  
In the intake and outlet area should not be any solid obstruction within 0,5 m.

Measurement setup:	Measured between two steel plates
Steel plate:	148 mm x 148 mm
Intake nozzle:	D: 66 mm; R: 7 mm
Distance between bottom and top plate:	
Overlapping impeller / nozzle:	1 mm

$\Delta p = 0$ : corresp. to free air flow (see chapter aerodynamics)

I: corresp. to arithm. mean current value

**Attention! The connected power supply must be limited to 11A.**

Features	Condition	Symbol	Values		
Voltage range		U	18 V		27,2 V
Nominal voltage		U <sub>N</sub>		24 V	
Power consumption	$\Delta p = 0$	P	21 W	23 W	22,8 W
Tolerance	0010		+/- 15 %	+/- 15 %	+/- 15 %
Current consumption	$\Delta p = 0$	I	1.160 mA	960 mA	840 mA
Tolerance	0010		+/- 15 %	+/- 15 %	+/- 15 %
Speed	$\Delta p = 0$	n	5.900 1/min	6.050 1/min	6.150 1/min
Tolerance	0010		+/- 12 %	+/- 12 %	+/- 12 %

3.2 Electrical Features

Electronic function	Speed-Current-Controlled	
Reversed polarity protection	Rectifying diode	
Max. residual current at $U_N$	$I_F \leq 100 \mu A$	
Locked rotor protection	Auto restart	
Locked rotor current at $U_N$	$I_{block}$ approx. 3.000 mA	
Clock signal at locked rotor	$t_3 / t_4$ typical: 1,0 s / 20,0 s	

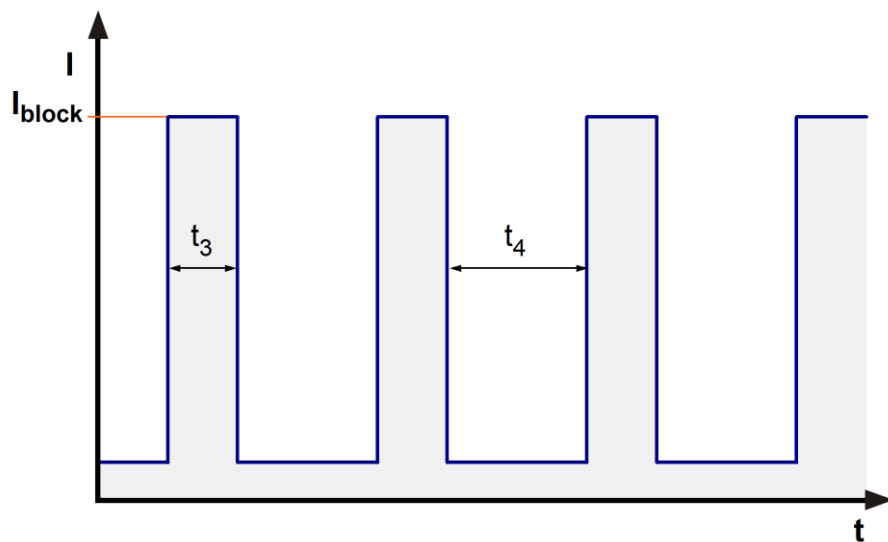

### 3.3 Aerodynamics

Measurement conditions: Measured with a double chamber intake rig acc. to DIN EN ISO 5801. Normal air density = 1,2 kg/m<sup>3</sup>; Temperature 23°C +/- 3°C; In the intake and outlet area should not be any solid obstruction within 0,5 m. Motor shaft horizontal. The information is only valid under the specified test conditions and may be changed by the installation conditions. If there are deviations from the standard test conditions, the characteristic values must be checked under the installed conditions.

Measurement setup:	Measured between two steel plates
Steel plate:	148 mm x 148 mm
Intake nozzle:	D: 66 mm; R: 7 mm
Distance between bottom and top plate:	
Overlapping impeller / nozzle:	1 mm

a.) Operation condition:

6.050 1/min at free air flow
------------------------------

Max. free-air flow ( $\Delta p = 0 / \dot{V} = \text{max.}$ )	192,0 m <sup>3</sup> /h	
Max. static pressure ( $\Delta p = \text{max.} / \dot{V} = 0$ )	440 Pa	

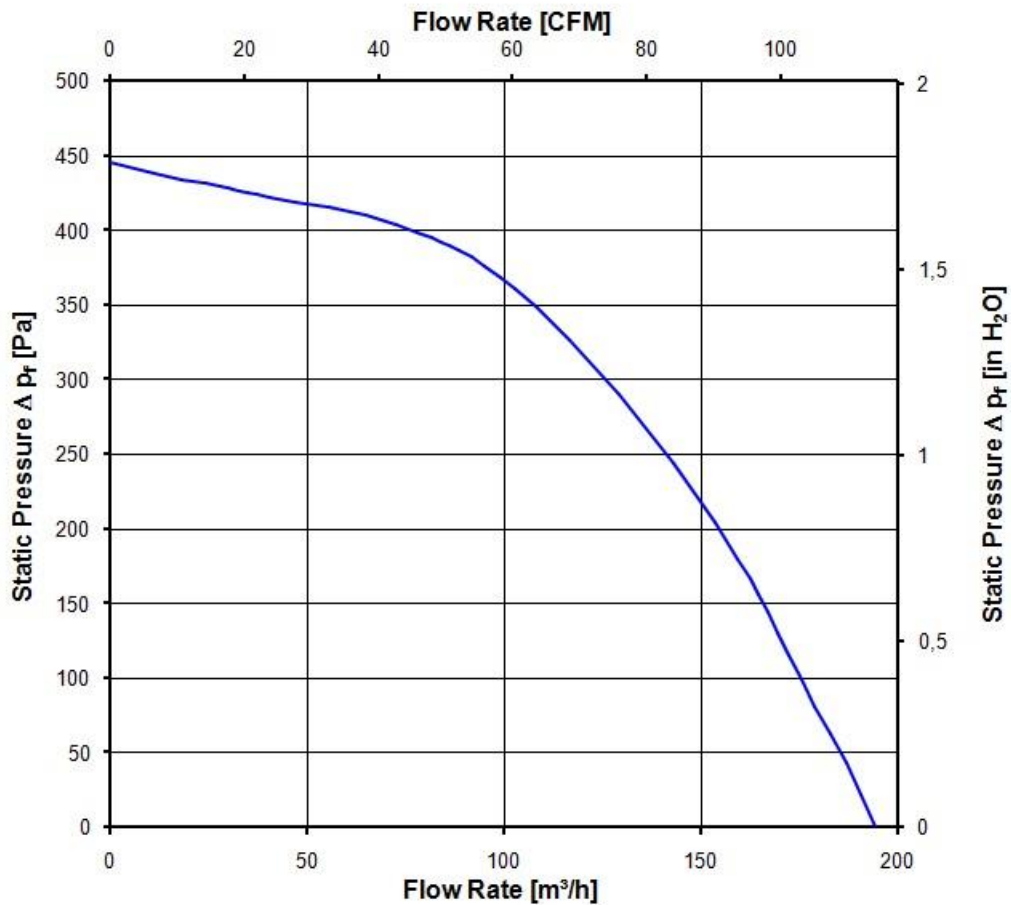

### 3.4 Sound Data

Measurement conditions: Sound pressure level: 1 meter distance between microphone and the air intake.  
Sound power level: Acc. to DIN 45635 part 38 (ISO 10302)  
Measured in a semianechoic chamber with a background noise level of  $L_p(A) < 5 \text{ dB(A)}$   
For further measurement conditions see chapter aerodynamics.

a.) Operation condition:

6.050 1/min at free air flow
------------------------------

Optimal operating point	75,0 m <sup>3</sup> /h @ 360 Pa	
Sound power level at the optimal operating point	7,4 bel(A)	
Sound pressure level at free air flow, measured in rubber bands		

## 4 Environment

### 4.1 General

Min. permitted ambient temperature TU min.	-20 °C	
Max. permitted ambient temperature TU max.	70 °C	
Min. permitted storage temperature TL min.	-40 °C	
Max. permitted storage temperature TL max.	80 °C	

### 4.2 Climatic Requirements

Humidity requirements	humid heat, constant; according to DIN EN 60068-2-78, 14 days	
Water exposure	None	
Dust requirements	None	
Salt fog requirements	None	

Permitted application area:

The product is intended for use in sheltered rooms with controlled temperature and controlled humidity. Directly exposure to water must be avoided.

Pollution degree 1 (according DIN EN 60664-1)

There is either no pollution or it occurs only dry, non-conductive pollution. The pollution has no negative impact.

Please require severity levels and specification parameters from the responsible development departments.

**5 Safety****5.1 Electrical Safety**

Dielectric strength DIN EN 62368 and DIN EN 60335 A.) Type test Measuring conditions: After 48h of storage at 95% R.H. and 25°C. No arcing or breakdown is allowed! All connections together to ground. B.) Routine test Measuring conditions: At indoor climate. No arcing or breakdown is allowed! All connections together to ground.	500 VAC / 1 Min.  850 VDC / 1 Sec.	
Isolation resistance Measuring conditions: After 48h of storage at 95% R.H. and 25°C measured with U=500 VDC for 1 min.	RI > 10 MOhm	
Clearance / creepage distance	1,0 mm / 1,2 mm	
Protection class	III	

**5.2 Approval Tests**

CE	EC Declaration of Conformity	Yes
EAC	Eurasian Conformity	Yes
UL	Underwriters Laboratories	Yes / UL507, Electric Fans E38324
VDE	Association for Electrical, Electronic and Information Technologies	No
CSA	Canadian Standards Association	Yes / CSA audited by UL according to C22.2 No. 113 Fans and Ventilators
CCC	China Compulsory Certification	Not applicable

**6 Reliability****6.1 General**

Life expectancy L10 at TU = 40 °C	60.000 h	
Life expectancy L10 at TU max.	30.000 h	
Life expectancy L10 acc. to IPC 9591 at TU = 40 °C	102.500 h	

Copying of this document and giving it to others and the use or communication of the contents thereof, are forbidden without express authority. Offences are liable to the payment of damages. All rights are reserved in the event of the grant of a patent or the registration of a utility model or design.

Schutzvermerk nach DIN ISO 9100, beachten/Refer. to protection notice DIN ISO 9100

Ⓑ Länge L und Anzahl der Litzen siehe Spezifikation

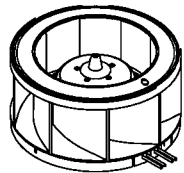
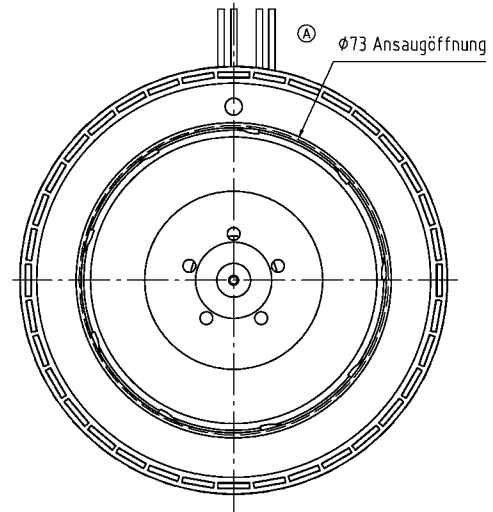
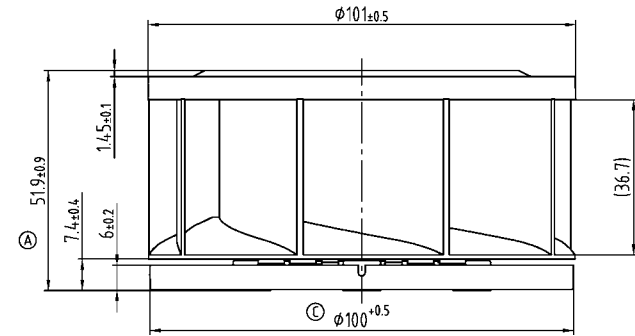
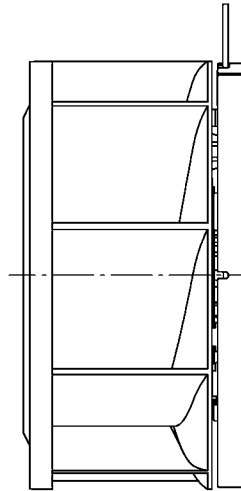
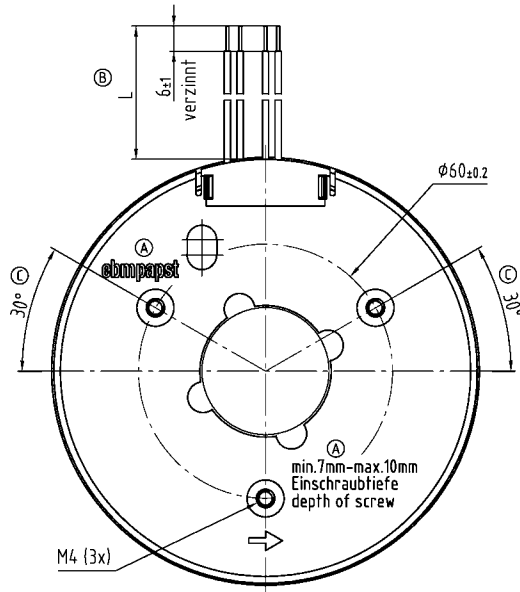

SAP-Status/State	Änd.-Nr./Change No.	AutoCAD-System-Version	ebmpapst	Werkstoff/Material:	Volumen/Volume (mm <sup>3</sup> ):
		Datum/Date	CAO-Umgebung/ CAO-Environment		Gewicht/Mass (g):
		Bearb./ Drawn	Name/Name	Artikel/Title	Ⓐ
Tolerierung/Tolerances:		Gepr./ Checked		Zchg.-Nr./ Drawing-No.:	Ers.f.Zchg./ Replaces
Allgemeintoleranzen/Gen. Tolerances:		Freig./ Released	<b>ebmpapst</b>	Dokumenttyp/Type of Document	Teildokument Blatt/Sheet
			ebm-papst St. Georgen GmbH & Co. KG	Index/Index	Format/Size
				Massstab/Scale	