

R6D450-AN01-01 ebmpapst Datasheet FansCo

sales@fansco.com

www.fansco.com

Nominal data

Type	R6D450-AN01-01				
Motor	M6D110-EF				
Phase		3~	3~	3~	3~
Nominal voltage	VAC	230	277	400	480
Wiring		Δ	Δ	Y	Y
Frequency	Hz	50	60	50	60
Method of obtaining data		ml	ml	ml	ml
Valid for approval/standard		-	-	-	-
Speed (rpm)	min ⁻¹	930	1110	930	1110
Power consumption	W	290	440	290	440
Current draw	A	1.3	1.4	0.75	0.81
Min. back pressure	Pa	0	0	0	0
Min. back pressure	in. wg	0	0	0	0
Min. ambient temperature	°C	-40	-40	-40	-40
Max. ambient temperature	°C	85	70	85	70
Starting current	A	4.5	5.1	2.6	2.9

ml = Max. load · me = Max. efficiency · fa = Free air · cs = Customer specification · ce = Customer equipment
Subject to change



Technical description

Weight	9.7 kg
Size	450 mm
Motor size	110
Impeller material	Sheet aluminum
Number of blades	6
Direction of rotation	Clockwise, viewed toward rotor
Degree of protection	IP54
Insulation class	"F"
Moisture (F) / Environmental (H) protection class	H2
Max. permitted ambient temp. for motor (transport/storage)	+80 °C
Min. permitted ambient temp. for motor (transport/storage)	-40 °C
Installation position	Shaft horizontal or rotor on bottom; rotor on top on request
Condensation drainage holes	On rotor side
Mode	S1
Motor bearing	Ball bearing
Touch current according to IEC 60990 (measuring circuit Fig. 4, TN system)	<= 3.5 mA
Motor protection	Thermal overload protector (TOP) with basic insulation
Protection class	I (with customer connection of protective earth)
Approval	CCC; EAC; UL 1004-1; CSA C22.2 No. 100; VDE

Product drawing

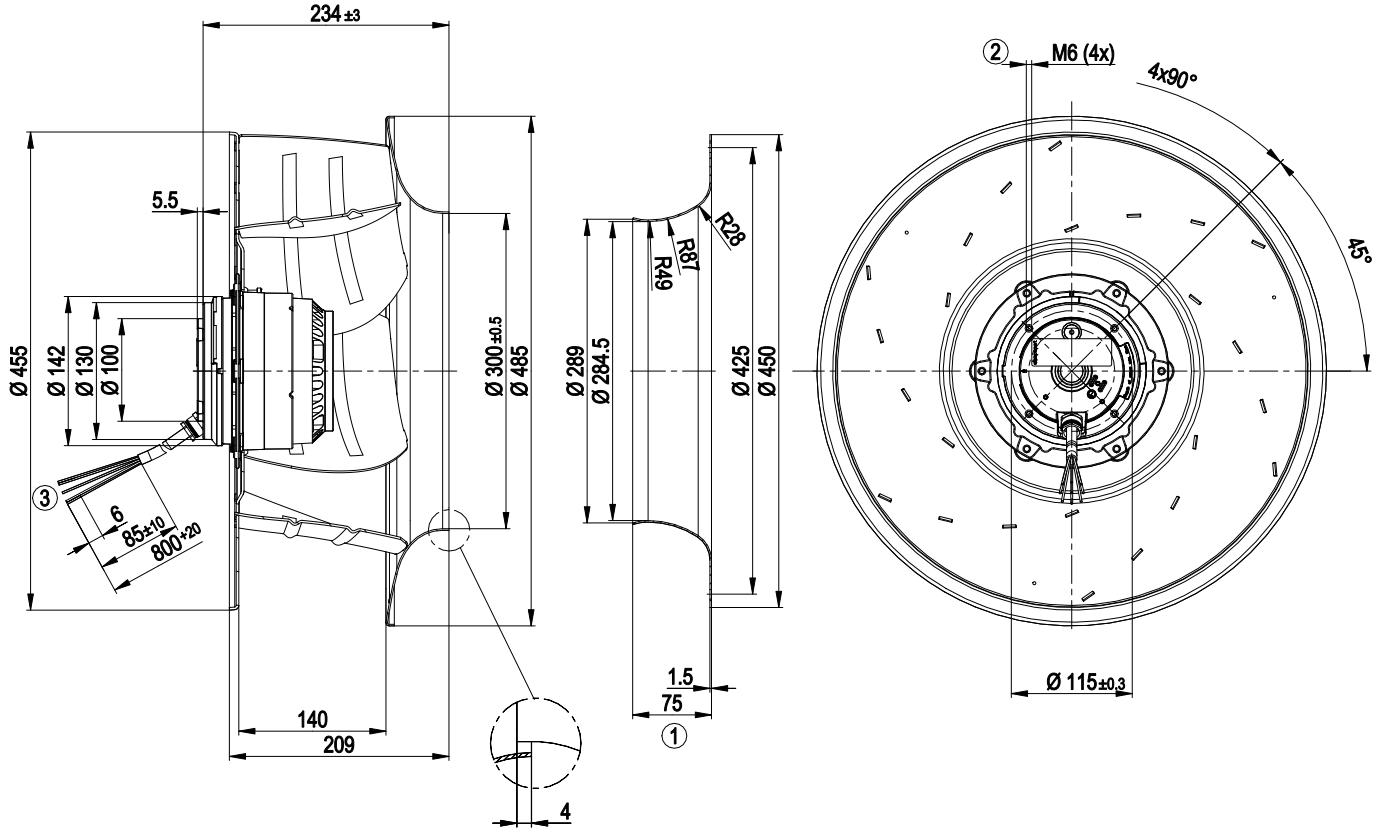

1	Accessory part: Inlet ring 63045-2-4013 not included in scope of delivery.
2	Max. clearance for screw 12 mm
3	Cable silicone 9 x 0.75 mm², 9 x crimped splices



Connection diagram

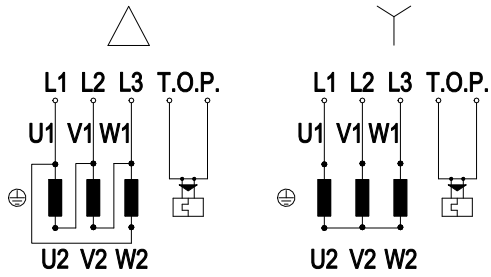

Note: Change of rotation direction by reversing two phases

Δ	Delta connection	Y	Star connection	L1	black
L2	blue	L3	brown	U1	black
V1	blue	W1	brown	U2	green
V2	white	W2	yellow	TOP	gray

Curves: Air performance 50 Hz Y

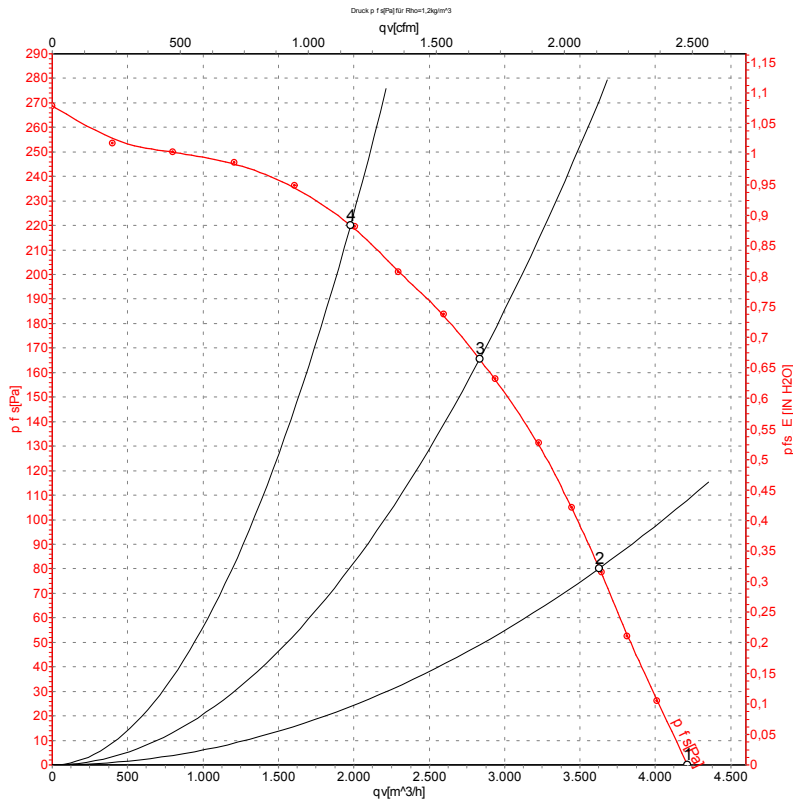

Measurement: LU-73887-1

Air performance measured according to ISO 5801 installation category A. For detailed information on the measurement setup, contact ebm-papst. Intake sound level: Sound power level according to ISO 13347 / sound pressure level measured at 1 m distance from fan axis. The values given are valid under the specified measuring conditions and may vary due to conditions of installation. For deviations from the standard configuration, the parameters have to be checked on the installed unit.

Measured values

	Wired	U	f	n	P _e	I	q _v	P _{fs}	q _v	P _{fs}
		V	Hz	min ⁻¹	W	A	m ³ /h	Pa	cfm	in. wg
1	Y	400	50	950	221	0.71	4215	0	2480	0.00
2	Y	400	50	940	260	0.73	3630	80	2135	0.32
3	Y	400	50	930	290	0.75	2835	165	1670	0.66
4	Y	400	50	935	274	0.73	1980	220	1165	0.88

Wired = Wiring · U = Voltage · f = Frequency · n = Speed (rpm) · P_e = Power consumption · I = Current draw · q_v = Air flow · P_{fs} = Pressure increase



Curves: Air performance 60 Hz Y

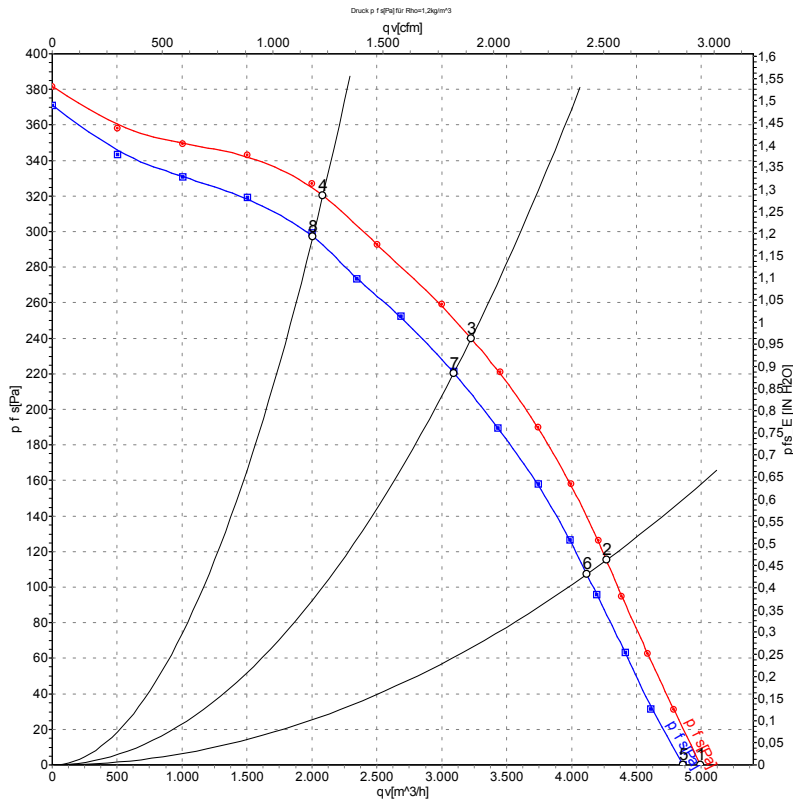

Measurement: LU-73891-1
Measurement: LU-73892-1

Air performance measured according to ISO 5801 installation category A. For detailed information on the measurement setup, contact ebmpapst. Intake sound level: Sound power level according to ISO 13347 / sound pressure level measured at 1 m distance from fan axis. The values given are valid under the specified measuring conditions and may vary due to conditions of installation. For deviations from the standard configuration, the parameters have to be checked on the installed unit.

Measured values

	Wired	U	f	n	P _e	I	q _v	P _{fs}	q _v	P _{fs}
		V	Hz	min ⁻¹	W	A	m ³ /h	Pa	cfm	in. wg
1	Y	480	60	1130	343	0.75	5000	0	2945	0.00
2	Y	480	60	1110	402	0.79	4270	115	2515	0.46
3	Y	480	60	1110	440	0.81	3225	240	1900	0.96
4	Y	480	60	1110	417	0.80	2085	320	1225	1.28
5	Y	400	60	1100	307	0.66	4860	0	2860	0.00
6	Y	400	60	1070	368	0.72	4120	107	2425	0.43
7	Y	400	60	1060	400	0.77	3095	221	1820	0.89
8	Y	400	60	1065	379	0.74	2010	299	1180	1.20

Wired = Wiring · U = Voltage · f = Frequency · n = Speed (rpm) · P_e = Power consumption · I = Current draw · q_v = Air flow · p_{fs} = Pressure increase

