

R4E450-FH07-01 ebmpapst Datasheet

sales@fansco.com

www.fansco.com

Limited partnership · Headquarters Mulfingen

Amtsgericht (court of registration) Stuttgart · HRA 590344

General partner Elektrobau Mulfingen GmbH · Headquarters Mulfingen

Amtsgericht (court of registration) Stuttgart · HRB 590142

## Nominal data

Type	R4E450-FH07-01	
Motor	M4E110-GF	
Phase		1~
Nominal voltage	VAC	230
Frequency	Hz	50
Method of obtaining data		ml
Valid for approval/standard		CE
Speed (rpm)	min <sup>-1</sup>	1360
Power consumption	W	710
Current draw	A	3.2
Capacitor	µF	16
Capacitor voltage	VDB	450
Capacitor standard		S0 (CE)
Min. back pressure	Pa	0
Min. back pressure	in. wg	0
Min. ambient temperature	°C	-40
Max. ambient temperature	°C	40
Starting current	A	8.0

ml = Max. load · me = Max. efficiency · fa = Free air · cs = Customer specification · ce = Customer equipment  
Subject to change

## Data according to Commission Regulation (EU) 327/2011 (prEN 17166)

		Actual	Req. 2015			
01 Overall efficiency $\eta_{es}$	%	53.4	49.7	09 Power consumption $P_e$	kW	0.66
02 Measurement category		A		09 Air flow $q_v$	m <sup>3</sup> /h	4545
03 Efficiency category		Static		09 Pressure increase $p_{fs}$	Pa	283
04 Efficiency grade N		65.7	62	10 Speed (rpm) n	min <sup>-1</sup>	1345
05 Variable speed drive		No		11 Specific ratio*		1.00

Data obtained at optimum efficiency level.

\* Specific ratio =  $1 + p_g / 100\,000\text{ Pa}$ 

LU-214719

The efficiency values displayed for achieving conformity with the Ecodesign Regulation EU 327/2011 has been reached with defined air duct components (e.g. inlet rings). The dimensions must be requested from ebm-papst. If other air conduction geometries are used on the installation side, the ebm-papst evaluation loses its validity/the conformity must be confirmed again. The product does not fall within the scope of Regulation (EU) 2019/1781 due to the exception specified in Article 2 (2a) (motors completely integrated into a product).



## Technical description

<b>Weight</b>	11.9 kg
<b>Size</b>	450 mm
<b>Motor size</b>	110
<b>Rotor surface</b>	Cast in aluminum
<b>Impeller material</b>	PP plastic
<b>Number of blades</b>	6
<b>Direction of rotation</b>	Clockwise, viewed toward rotor
<b>Degree of protection</b>	IP54
<b>Insulation class</b>	"F"
<b>Moisture (F) / Environmental (H) protection class</b>	H2
<b>Ambient temperature note</b>	Occasional start-up at temperatures between -40°C and -25°C is permitted. For continuous operation at ambient temperatures below -25°C (such as refrigeration applications), use must be made of a fan design with special low-temperature bearings.
<b>Max. permitted ambient temp. for motor (transport/storage)</b>	+80 °C
<b>Min. permitted ambient temp. for motor (transport/storage)</b>	-40 °C
<b>Installation position</b>	Shaft horizontal or rotor on bottom; rotor on top on request
<b>Condensation drainage holes</b>	On rotor side
<b>Mode</b>	S1
<b>Motor bearing</b>	Ball bearing
<b>Touch current according to IEC 60990 (measuring circuit Fig. 4, TN system)</b>	<= 3.5 mA
<b>Motor protection</b>	Thermal overload protector (TOP) with basic insulation
<b>Protection class assignment</b>	I; If a protective earth is connected by the customer This component for installation may have several local protection classes. This information relates to this component's basic design. The final protection class is based on the component's intended installation and connection.
<b>Conformity with standards</b>	EN 60034-1; CE
<b>Approval</b>	VDE; CSA C22.2 No. 100; EAC; UL 1004-1

Product drawing

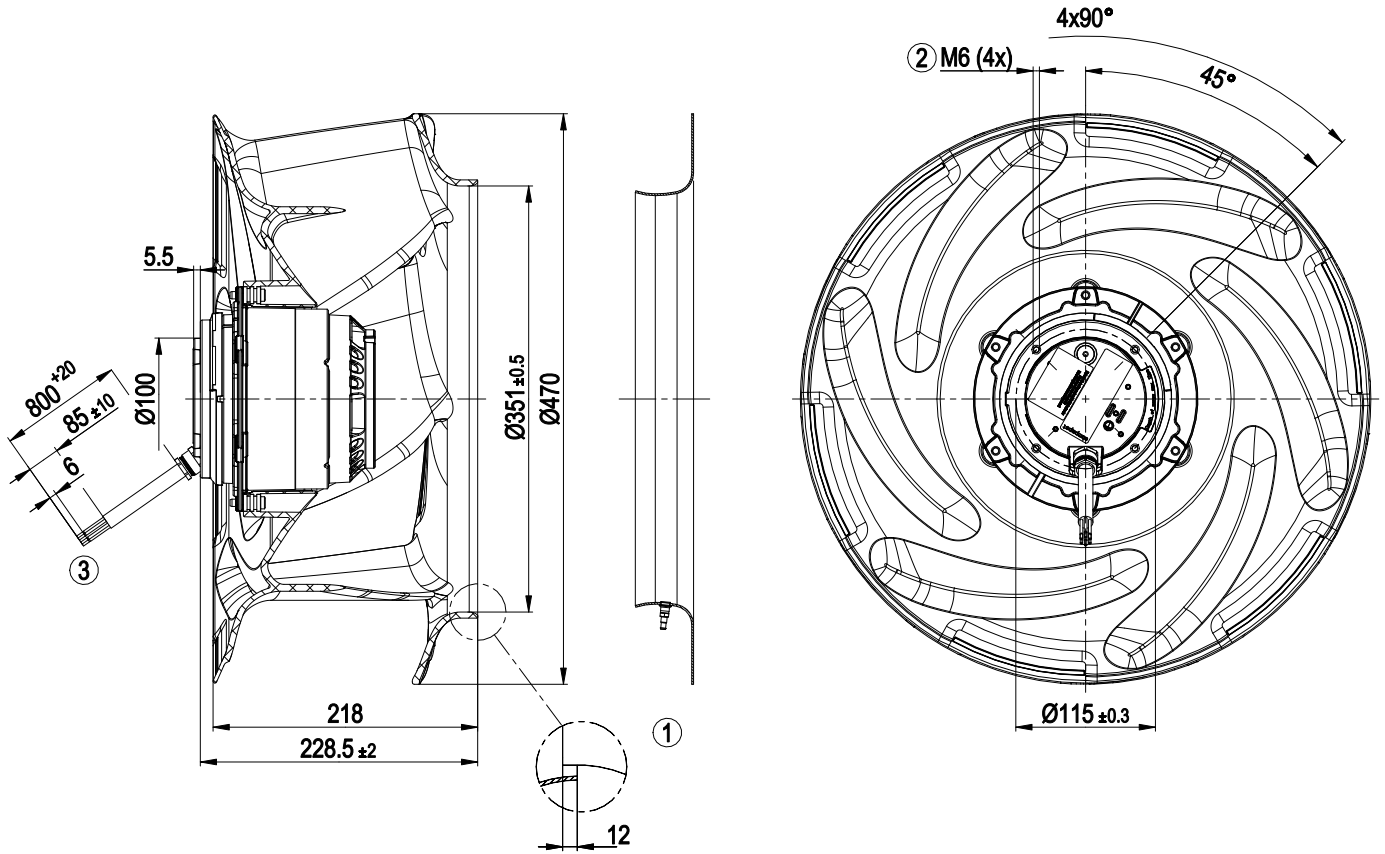

1	Accessory part: Inlet ring 45355-2-4013 with pressure tap (k-factor: 250) (not included in scope of delivery)
2	Max. clearance for screw 12 mm
3	Cable silicone 6G 0.5 mm <sup>2</sup>
	6x splice

## Accessory part

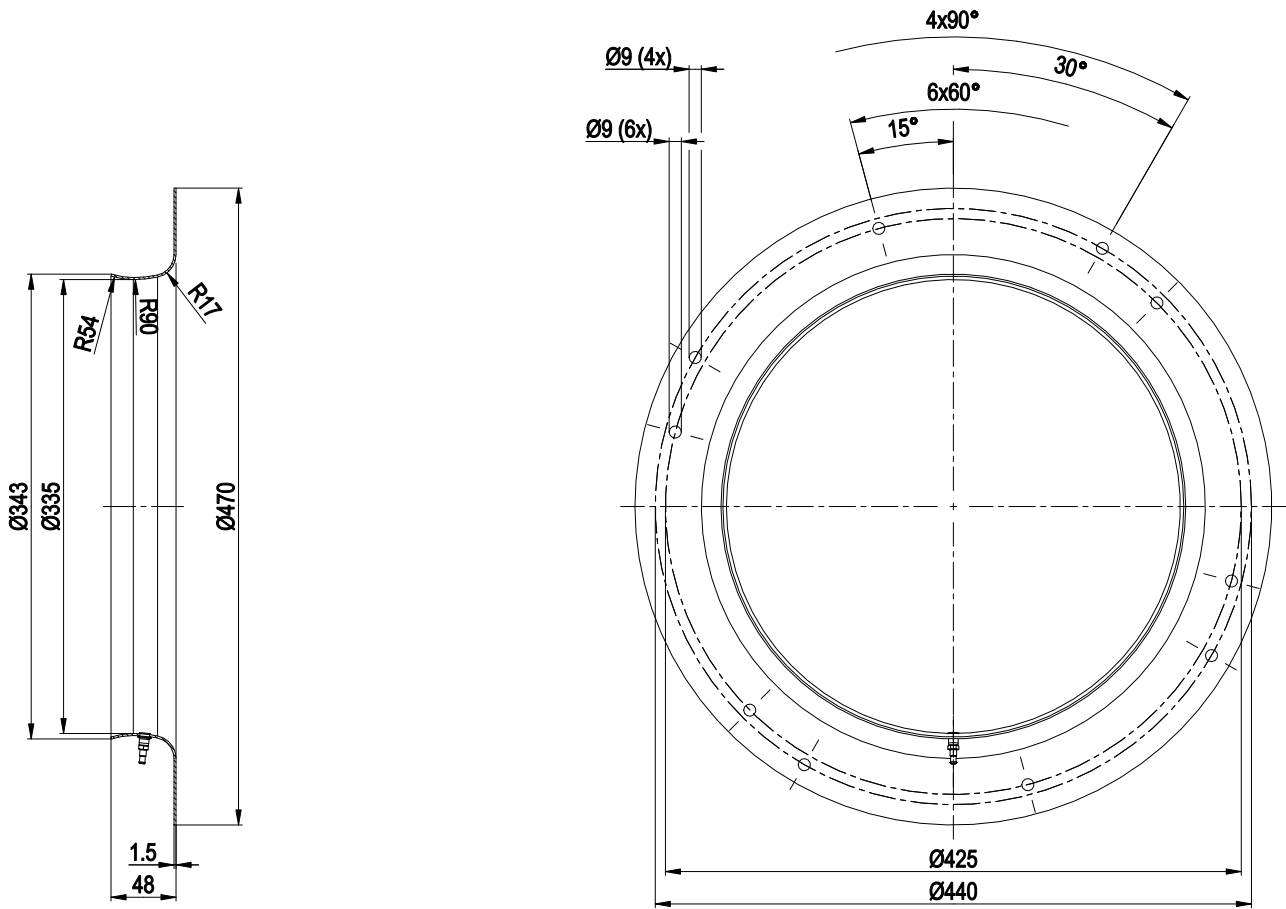

Inlet ring 45355-2-4013 with pressure tap (k-factor: 250)

## Connection diagram

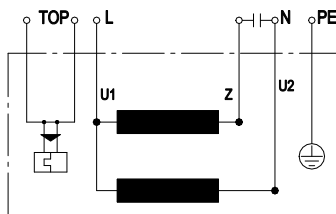

U1	blue	Z	brown	U2	black
PE	green/yellow	TOP	2x gray		



## Curves: Air performance 50 Hz

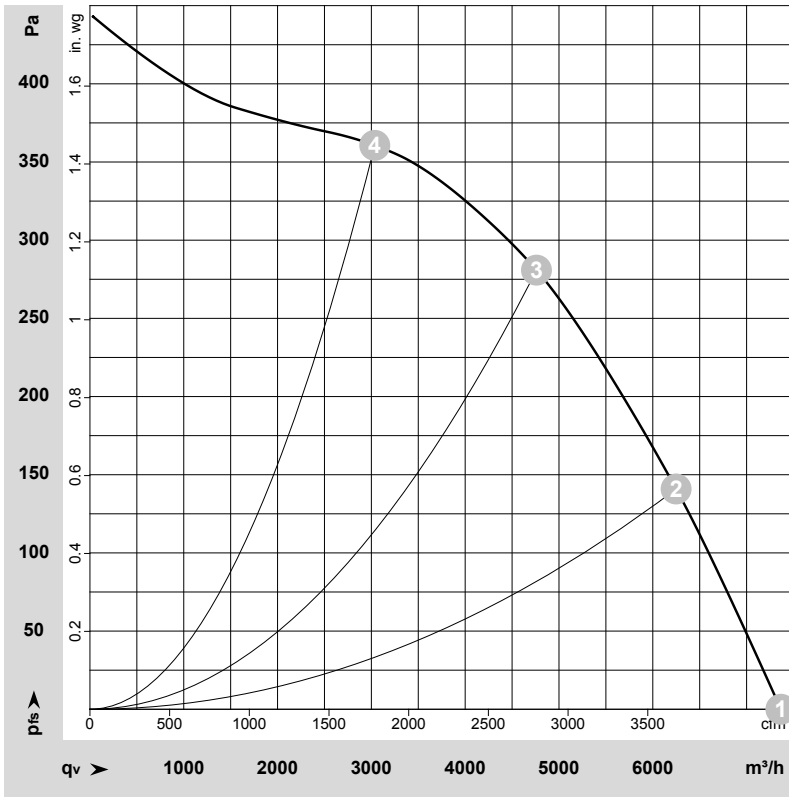

$\rho = 1.15 \text{ kg/m}^3 \pm 2 \%$

Measurement: LU-214719-1

Air performance measured according to ISO 5801 installation category A. For detailed information on the measurement setup, contact ebmpapst. Intake sound level: Sound power level according to ISO 13347 / sound pressure level measured at 1 m distance from fan axis. The values given are valid under the specified measuring conditions and may vary due to conditions of installation. For deviations from the standard configuration, the parameters have to be checked on the installed unit.

## Measured values

	Wired	U	f	n	P <sub>e</sub>	I	LpA <sub>in</sub>	LwA <sub>in</sub>	LwA <sub>out</sub>	q <sub>v</sub>	p <sub>fs</sub>	q <sub>v</sub>	p <sub>fs</sub>
		V	Hz	min <sup>-1</sup>	W	A	dB(A)	dB(A)	dB(A)	m <sup>3</sup> /h	Pa	cfm	in. wg
1	1~	230	50	1420	537	2.39	68	76	80	7365	0	4335	0.00
2	1~	230	50	1390	643	2.84	65	73	78	6250	140	3680	0.56
3	1~	230	50	1360	710	3.20	62	70	75	4760	280	2800	1.12
4	1~	230	50	1380	667	2.94	64	72	76	3035	360	1785	1.45

Wired = Wiring · U = Voltage · f = Frequency · n = Speed (rpm) · P<sub>e</sub> = Power consumption · I = Current draw · LpA<sub>in</sub> = Sound pressure level intake side · LwA<sub>in</sub> = Sound power level intake side  
 LwA<sub>out</sub> = Sound power level outlet side · q<sub>v</sub> = Air flow · p<sub>fs</sub> = Pressure increase

