

R4E355-AG04-13

AC centrifugal fan

backward-curved, single-intake



R4E355-AG04-13 ebmpapst Datasheet

sales@fansco.com

www.fansco.com

Nominal data

Type	R4E355-AG04-13			
Motor	M4E074-GA			
Phase		1~	1~	1~
Nominal voltage	VAC	115	115	115
Frequency	Hz	50	60	60
Method of obtaining data		fa	fa	fa
Valid for approval/standard		CE	CE	UL 2111
Speed (rpm)	min ⁻¹	1430	1680	1680
Power consumption	W	210	350	360
Current draw	A	2.0	3.1	3.05
Capacitor	µF	25	30	30
Capacitor voltage	VDB	220	220	220
Capacitor standard		S2 (CE)	S2 (CE)	UL
Min. back pressure	Pa		0	0
Min. back pressure	inH2O		0	0
Min. ambient temperature	°C	-25	-25	-25
Max. ambient temperature	°C	40	40	40
Starting current	A	5.5	11	

ml = Max. load · me = Max. efficiency · fa = Free air · cs = Customer specification · ce = Customer equipment
Subject to change



Technical description

Weight	5.4 kg
Fan size	355 mm
Rotor surface	Painted black
Impeller material	PP plastic
Number of blades	6
Direction of rotation	Clockwise, viewed toward rotor
Degree of protection	IP44; installation- and position-dependent as per EN 60034-5
Insulation class	"F"
Moisture (F) / Environmental (H) protection class	H0+
Max. permitted ambient temp. for motor (transport/storage)	+ 80 °C
Min. permitted ambient temp. for motor (transport/storage)	- 40 °C
Installation position	Shaft horizontal or rotor on bottom; rotor on top on request
Condensation drainage holes	On rotor side
Mode	S1
Motor bearing	Ball bearing
Touch current according to IEC 60990 (measuring circuit Fig. 4, TN system)	< 0.75 mA
Motor protection	Thermal overload protector (TOP) internally connected
With cable	Axial
Protection class	I (with customer connection of protective earth)
Conformity with standards	EN 60335-1; CE
Approval	CSA C22.2 No. 100; UL 1004-1

AC centrifugal fan

backward-curved, single-intake

Product drawing

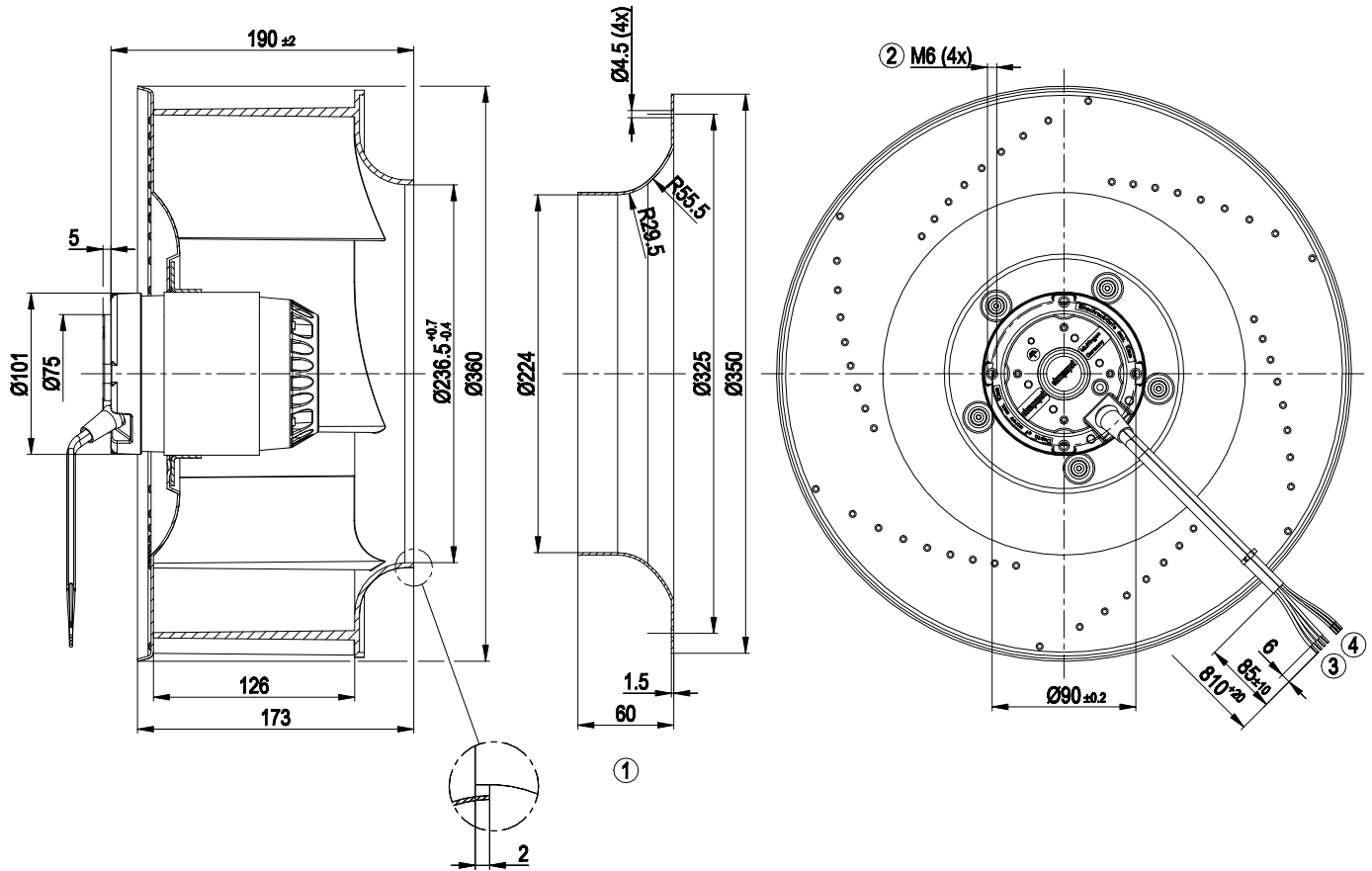

1	Accessory part: Inlet ring 51357-2-4013 not included in scope of delivery, other inlet rings on request
2	Max. clearance for screw 10 mm
3	Cable PFA AWG20, 4x crimped splices
4	Cable PVC AWG26, 3x crimped splices



Connection diagram

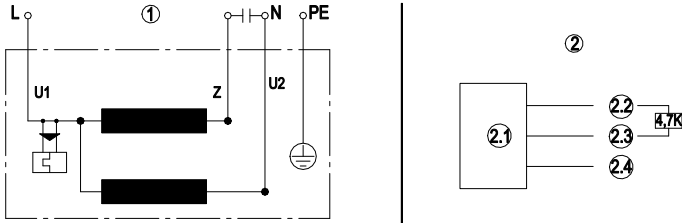

1	Fan connection diagram
U1	blue
Z	brown
U2	black
PE	green/yellow
2	Hall IC circuit
2.1	Hall IC
2.2	red (+5 V)
2.3	white (out)
2.4	black (0 V)

Curves: Air performance 60 Hz

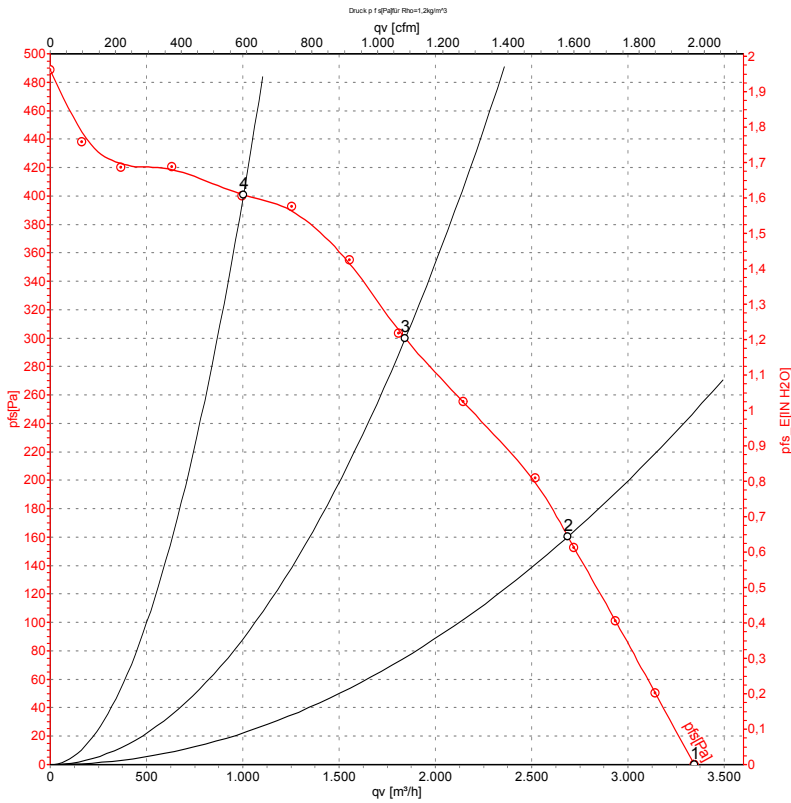

Measurement: LU-27965-1

Air performance measured according to ISO 5801 installation category A. For detailed information on the measurement setup, contact ebm-papst. Intake sound level: Sound power level according to ISO 13347 / sound pressure level measured at 1 m distance from fan axis. The values given are valid under the specified measuring conditions and may vary due to conditions of installation. For deviations from the standard configuration, the parameters have to be checked on the installed unit.

Measured values

	U	f	n	P _e	I	q _v	p _{fs}	q _v	p _{fs}
	V	Hz	min ⁻¹	W	A	m ³ /h	Pa	cfm	inH ₂ O
1	115	60	1680	350	3.10	3345	0	1970	0.00
2	115	60	1615	391	3.40	2690	160	1585	0.64
3	115	60	1520	419	3.67	1845	300	1085	1.20
4	115	60	1635	385	3.31	1005	400	590	1.61

U = Power supply · f = Frequency · n = Speed (rpm) · P_e = Power consumption · I = Current draw · q_v = Air flow · p_{fs} = Pressure increase

