

R4E280-AN67-10 ebmpapst Datasheet

sales@fansco.com

www.fansco.com

Limited partnership · Headquarters Muldingen

Amtsgericht (court of registration) Stuttgart · HRA 590344

General partner Elektrobau Muldingen GmbH · Headquarters Muldingen

Amtsgericht (court of registration) Stuttgart · HRB 590142

## Nominal data

Type	R4E280-AN67-10	
Motor	M4E068-DF	
Phase		1~
Nominal voltage	VAC	230
Frequency	Hz	50
Method of obtaining data		ce
Valid for approval/standard		CE
Speed (rpm)	min <sup>-1</sup>	1090
Power consumption	W	88
Current draw	A	0.39
Capacitor	µF	3
Capacitor voltage	VDB	400
Capacitor standard		S2 (CE)
Min. back pressure	Pa	0
Min. back pressure	inH2O	0
Min. ambient temperature	°C	-25
Max. ambient temperature	°C	45
Starting current	A	0.55

ml = Max. load · me = Max. efficiency · fa = Free air · cs = Customer specification · ce = Customer equipment  
Subject to change



### Technical description

Weight	2.3 kg
Fan size	280 mm
Rotor surface	Painted black
Impeller material	PA plastic
Number of blades	9
Direction of rotation	Counterclockwise, viewed toward rotor
Degree of protection	IP44; installation- and position-dependent as per EN 60034-5
Insulation class	"B"
Moisture (F) / Environmental (H) protection class	H0+
Max. permitted ambient temp. for motor (transport/storage)	+ 80 °C
Min. permitted ambient temp. for motor (transport/storage)	- 40 °C
Installation position	Shaft horizontal or rotor on bottom; rotor on top on request
Condensation drainage holes	On rotor side
Mode	S1
Motor bearing	Ball bearing
Speed levels	3
Touch current according to IEC 60990 (measuring circuit Fig. 4, TN system)	< 0.75 mA
Motor protection	Thermal overload protector (TOP) with basic insulation
With cable	Variable
Protection class	I (with customer connection of protective earth)
Conformity with standards	EN 60335-1; CE

## Product drawing

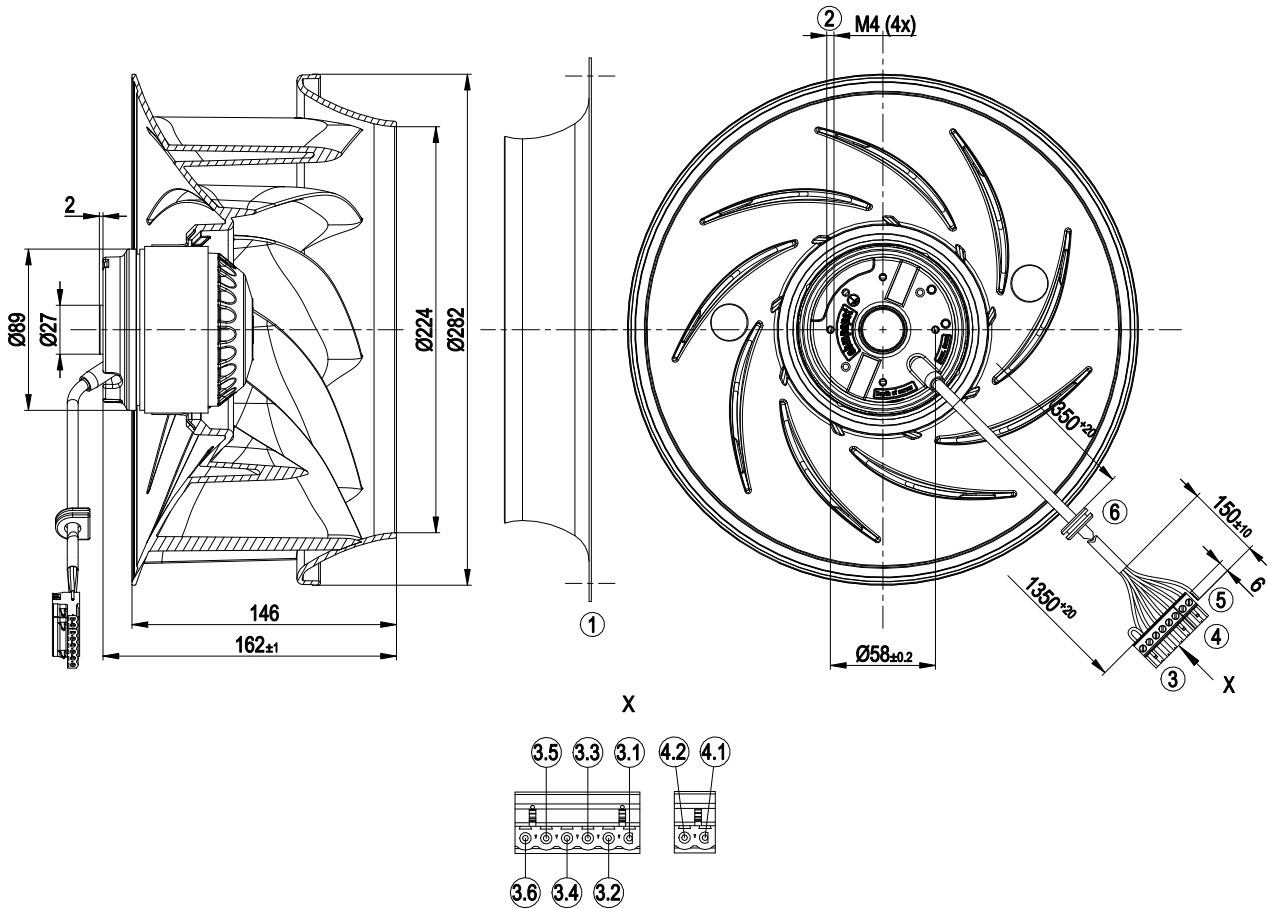

1	Accessory part: inlet ring 31050-2-4013 not included in scope of delivery
2	Max. clearance for screw 5 mm
3	Cable ETFE AWG20, 1x 6-pole connector housing Phönix 1757051 (MSTB 2.5/6-ST/5.08)
3.1	red (capacitor)
3.2	white (step 1)
3.4	gray (step 2)
3.4	black (step 3)
3.5	blue (N)
3.6	orange (bridge)
4	Cable ETFE AWG20, 1x 2-pole connector housing Phönix 1757019 (MSTB 2.5/2-ST/5.08)
4.1	yellow (TW)
4.2	yellow (TW)
5	Cable ETFE AWG20, 1x crimped splice (green/yellow)
6	Grommet 64901-4-7011 EPDM black

# AC centrifugal fan

backward-curved, single-intake

## Accessory part

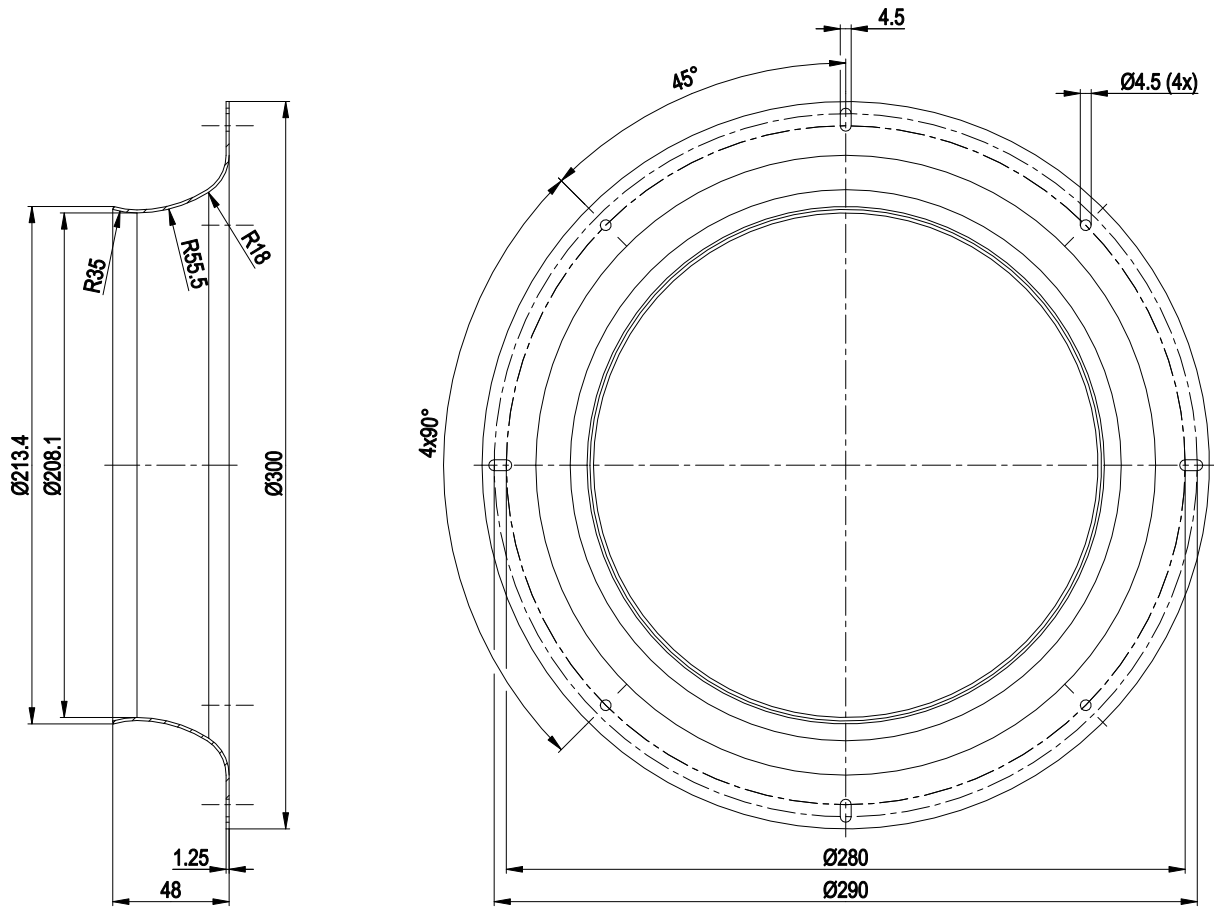

inlet ring 31050-2-4013 not included in scope of delivery



## Connection diagram

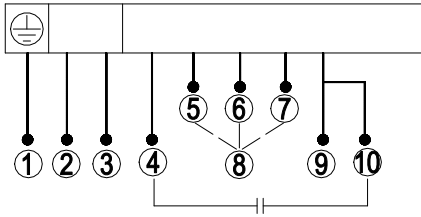

Note: High speed (step III); low speed (step I)

1	PE (green/yellow)	2	TW (yellow)	3	TW (yellow)
4	Capacitor (red)	5	L = step 1 (white)	6	L = step 2 (gray)
7	L = step 3 (black)	8	L1	9	N (blue)
10	Capacitor (orange)				

## Curves: Air performance 50 Hz

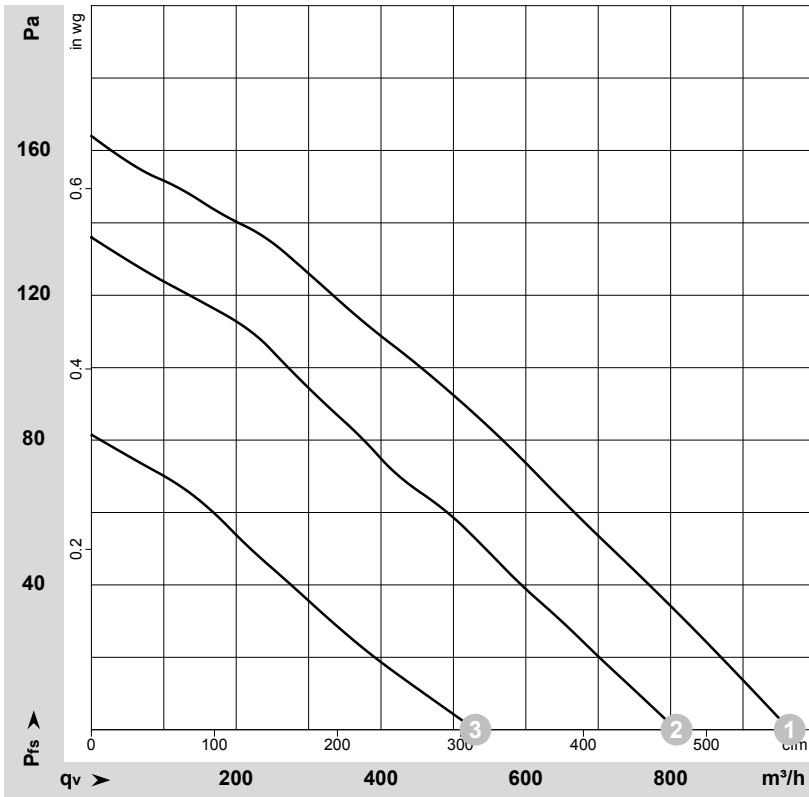

$\rho = 1.15 \text{ kg/m}^3 \pm 2 \%$

Measurement: LU-66162-1  
 Measurement: LU-66163-1  
 Measurement: LU-66164-1

Air performance measured according to ISO 5801 installation category A. For detailed information on the measurement setup, contact ebmpapst. Intake sound level: Sound power level according to ISO 13347 / sound pressure level measured at 1 m distance from fan axis. The values given are valid under the specified measuring conditions and may vary due to conditions of installation. For deviations from the standard configuration, the parameters have to be checked on the installed unit.

## Measured values

	Stage	U	f	n	P <sub>e</sub>	I	LpA <sub>in</sub>	q <sub>v</sub>	q <sub>v</sub>	P <sub>fs</sub>
		V	Hz	min <sup>-1</sup>	W	A	dB(A)	m <sup>3</sup> /h	cfm	inH2O
1	3	230	50	1090	88	0.39	50	965	570	0.00
2	2	230	50	930	74	0.33	46	805	475	0.00
3	1	230	50	630	55	0.26	35	530	310	0.00

U = Power supply · f = Frequency · n = Speed (rpm) · P<sub>e</sub> = Power consumption · I = Current draw · LpA<sub>in</sub> = Sound pressure level intake side · q<sub>v</sub> = Air flow

