

R4E280-AA01-13

AC centrifugal fan

backward-curved, single-intake



R4E280-AA01-13 ebmpapst Datasheet

sales@fansco.com

www.fansco.com

Limited partnership · Headquarters Muldingen

Amtsgericht (court of registration) Stuttgart · HRA 590344

General partner Elektrobau Muldingen GmbH · Headquarters Muldingen

Amtsgericht (court of registration) Stuttgart · HRB 590142

Nominal data

Type	R4E280-AA01-13		
Motor	M4E068-DF		
Phase		1~	1~
Nominal voltage	VAC	230	230
Frequency	Hz	50	60
Method of obtaining data		fa	fa
Valid for approval/standard		CE	CE
Speed (rpm)	min ⁻¹	1350	1530
Power consumption	W	90	125
Current draw	A	0.40	0.55
Capacitor	µF	3	3
Capacitor voltage	VDB	450	450
Capacitor standard		S0 (CE)	
Min. back pressure	Pa	0	0
Min. back pressure	inH2O	0	0
Min. ambient temperature	°C	-25	-25
Max. ambient temperature	°C	55	50
Starting current	A	0.72	0.7

ml = Max. load · me = Max. efficiency · fa = Free air · cs = Customer specification · ce = Customer equipment
Subject to change



Technical description

Weight	3.1 kg
Fan size	280 mm
Rotor surface	Painted black
Impeller material	Sheet steel, painted black
Number of blades	8
Direction of rotation	Clockwise, viewed toward rotor
Degree of protection	IP44; installation- and position-dependent as per EN 60034-5
Insulation class	"F"
Moisture (F) / Environmental (H) protection class	H0+
Max. permitted ambient temp. for motor (transport/storage)	+ 80 °C
Min. permitted ambient temp. for motor (transport/storage)	- 40 °C
Installation position	Shaft horizontal or rotor on bottom; rotor on top on request
Condensation drainage holes	On rotor side
Mode	S1
Motor bearing	Ball bearing
Touch current according to IEC 60990 (measuring circuit Fig. 4, TN system)	< 0.75 mA
With cable	Variable
Protection class	I (with customer connection of protective earth)
Conformity with standards	EN 60335-1, motor does not have factory-installed overheating protection
Approval	EAC

Product drawing

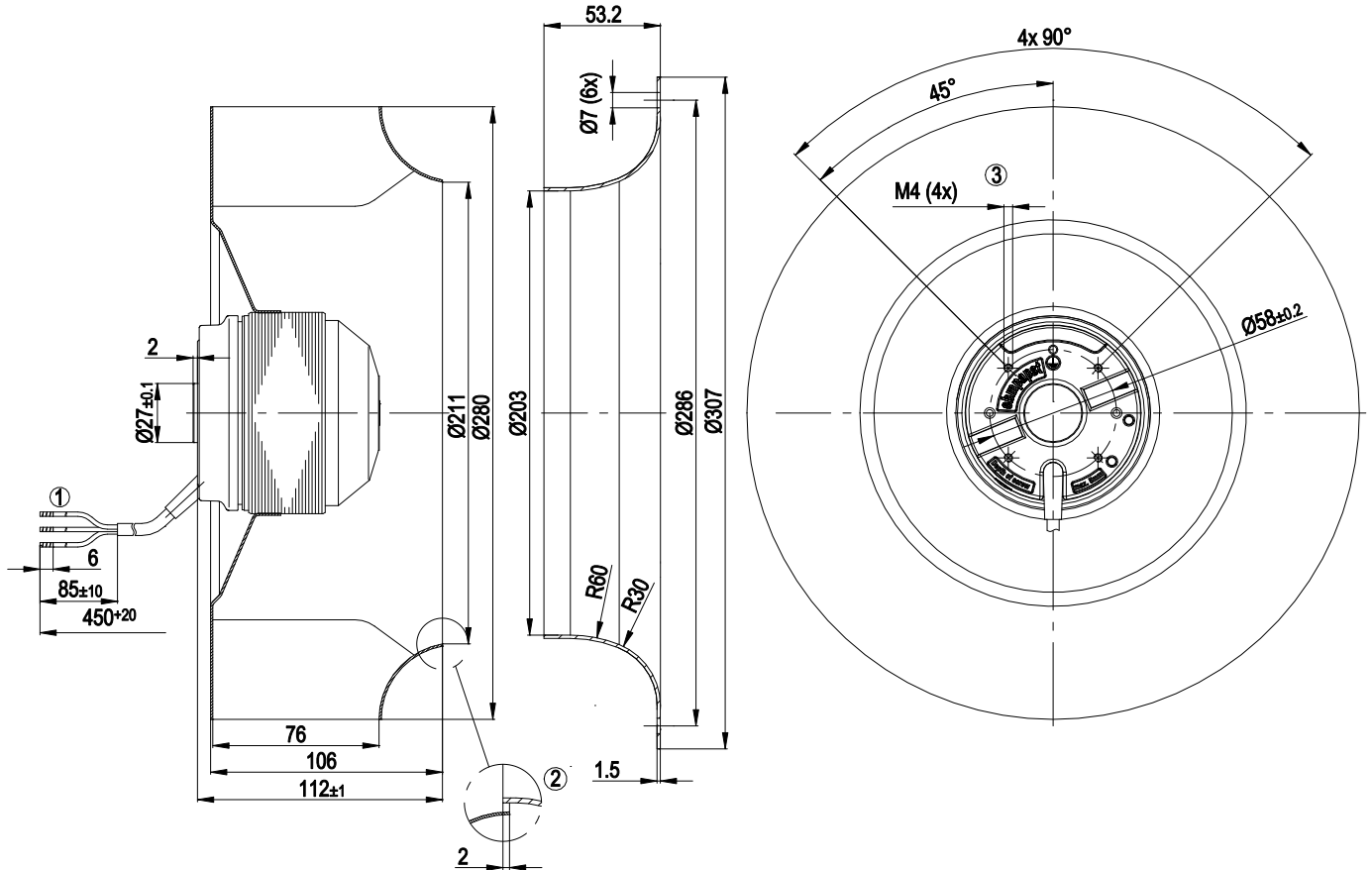

- | | |
|---|---|
| 1 | Cable silicone 3 x 0.5 mm ² , 3x crimped splices |
| 2 | Accessory part: Inlet ring 10040-2-4013 not included in scope of delivery |
| 3 | Max. clearance for screw 5 mm |

Connection diagram

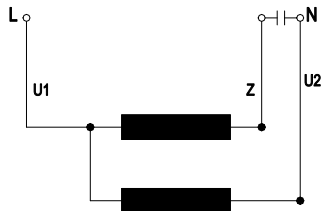

- | | | | | | |
|----|------|----|-------|---|-------|
| U1 | blue | U2 | black | Z | brown |
|----|------|----|-------|---|-------|



Curves: Air performance 50 Hz

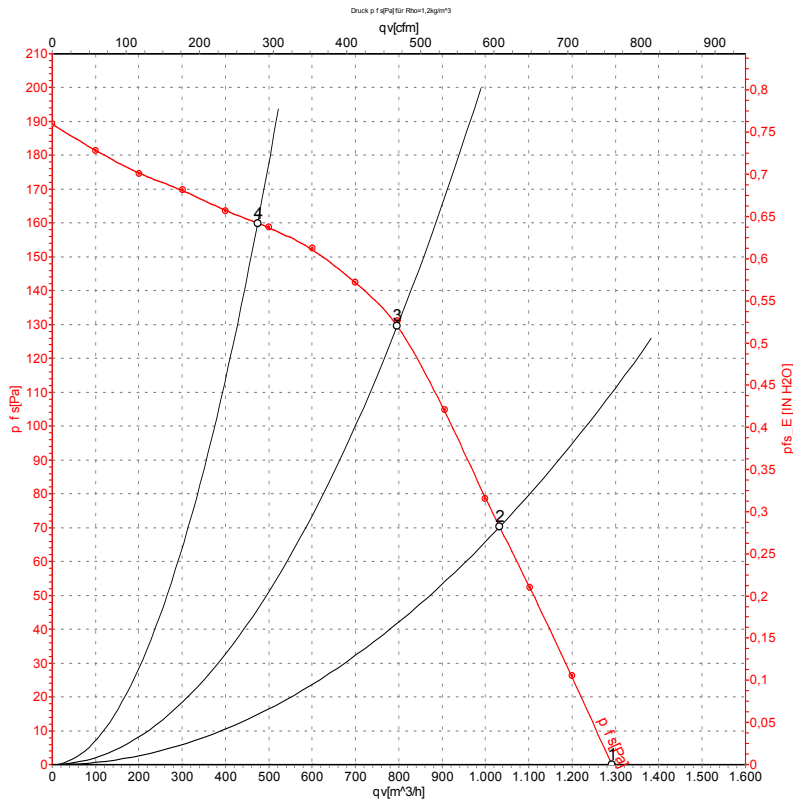

Measurement: LU-61007-1

Air performance measured according to ISO 5801 installation category A. For detailed information on the measurement setup, contact ebm-papst. Intake sound level: Sound power level according to ISO 13347 / sound pressure level measured at 1 m distance from fan axis. The values given are valid under the specified measuring conditions and may vary due to conditions of installation. For deviations from the standard configuration, the parameters have to be checked on the installed unit.

Measured values

	U	f	n	P _e	I	q _v	P _{fs}	q _v	P _{fs}
	V	Hz	min ⁻¹	W	A	m ³ /h	Pa	cfm	inH ₂ O
1	230	50	1350	90	0.40	1290	0	760	0.00
2	230	50	1325	97	0.42	1035	70	610	0.28
3	230	50	1325	98	0.43	795	130	470	0.52
4	230	50	1350	93	0.41	475	160	280	0.64

U = Power supply · f = Frequency · n = Speed (rpm) · P_e = Power consumption · I = Current draw · q_v = Air flow · P_{fs} = Pressure increase



Curves: Air performance 60 Hz

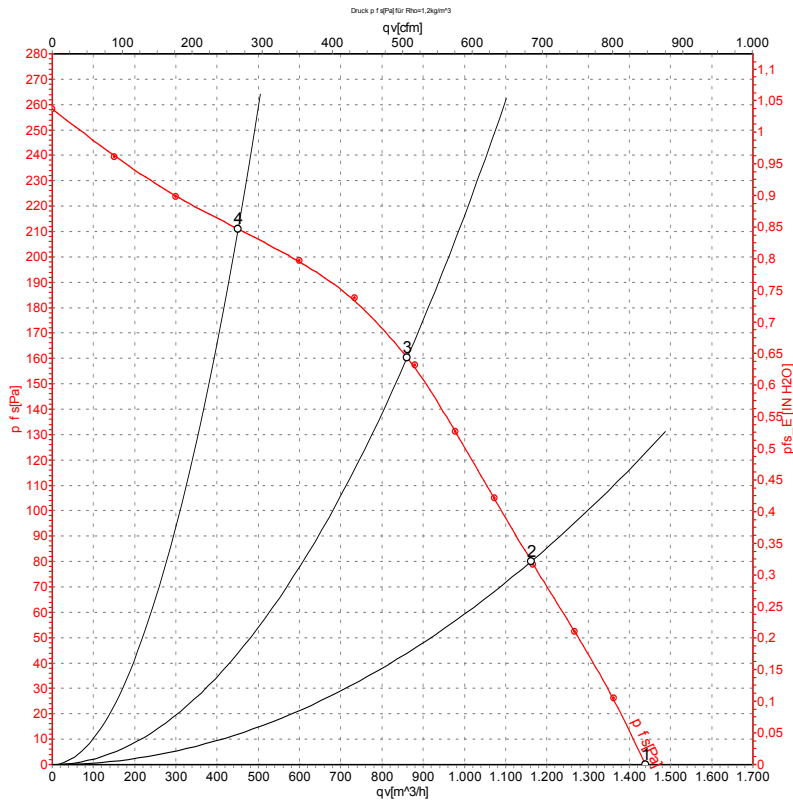

Measurement: LU-61008-1

Air performance measured according to ISO 5801 installation category A. For detailed information on the measurement setup, contact ebm-papst. Intake sound level: Sound power level according to ISO 13347 / sound pressure level measured at 1 m distance from fan axis. The values given are valid under the specified measuring conditions and may vary due to conditions of installation. For deviations from the standard configuration, the parameters have to be checked on the installed unit.

Measured values

	U	f	n	P _e	I	q _v	P _{fs}	q _v	P _{fs}
	V	Hz	min ⁻¹	W	A	m ³ /h	Pa	cfm	inH ₂ O
1	230	60	1530	125	0.55	1440	0	850	0.00
2	230	60	1465	132	0.57	1160	80	685	0.32
3	230	60	1470	132	0.57	860	161	505	0.65
4	230	60	1535	125	0.54	450	211	265	0.85

U = Power supply · f = Frequency · n = Speed (rpm) · P_e = Power consumption · I = Current draw · q_v = Air flow · P_{fs} = Pressure increase

