

R4E225-BK05-03 ebmpapst Datasheet FansCo

sales@fansco.com

www.fansco.com

Nominal data

Type	R4E225-BK05-03		
Motor	M4E094-FA		
Phase		1~	1~
Nominal voltage	VAC	230	230
Frequency	Hz	50	60
Method of obtaining data		fa	ml
Valid for approval/standard		-	-
Speed (rpm)	min ⁻¹	1330	1500
Power consumption	W	395	500
Current draw	A	1.98	2.3
Capacitor	μF	6	6
Capacitor voltage	VDB	450	450
Min. back pressure	Pa	0	100
Min. back pressure	inH ₂ O	0	0.4
Min. ambient temperature	°C	-40	-40
Max. ambient temperature	°C	70	50
Starting current	A	4.32	4

ml = Max. load · me = Max. efficiency · fa = Free air · cs = Customer specification · ce = Customer equipment
Subject to change



Technical description

Weight	6.1 kg
Fan size	225 mm
Rotor surface	Painted black
Impeller material	Sheet steel, galvanized
Direction of rotation	Clockwise, viewed toward rotor
Degree of protection	IP54
Insulation class	"F"
Moisture (F) / Environmental (H) protection class	F4-1
Max. permitted ambient temp. for motor (transport/storage)	+80 °C
Min. permitted ambient temp. for motor (transport/storage)	-40 °C
Installation position	Any
Condensation drainage holes	None
Mode	S1
Motor bearing	Ball bearing
Touch current according to IEC 60990 (measuring circuit Fig. 4, TN system)	≤ 3.5 mA
Motor protection	Thermal overload protector (TOP) with basic insulation
With cable	Variable
Protection class	I (with customer connection of protective earth)
Conformity with standards	EN 60034-1 (2010)
Approval	CCC; EAC

Product drawing

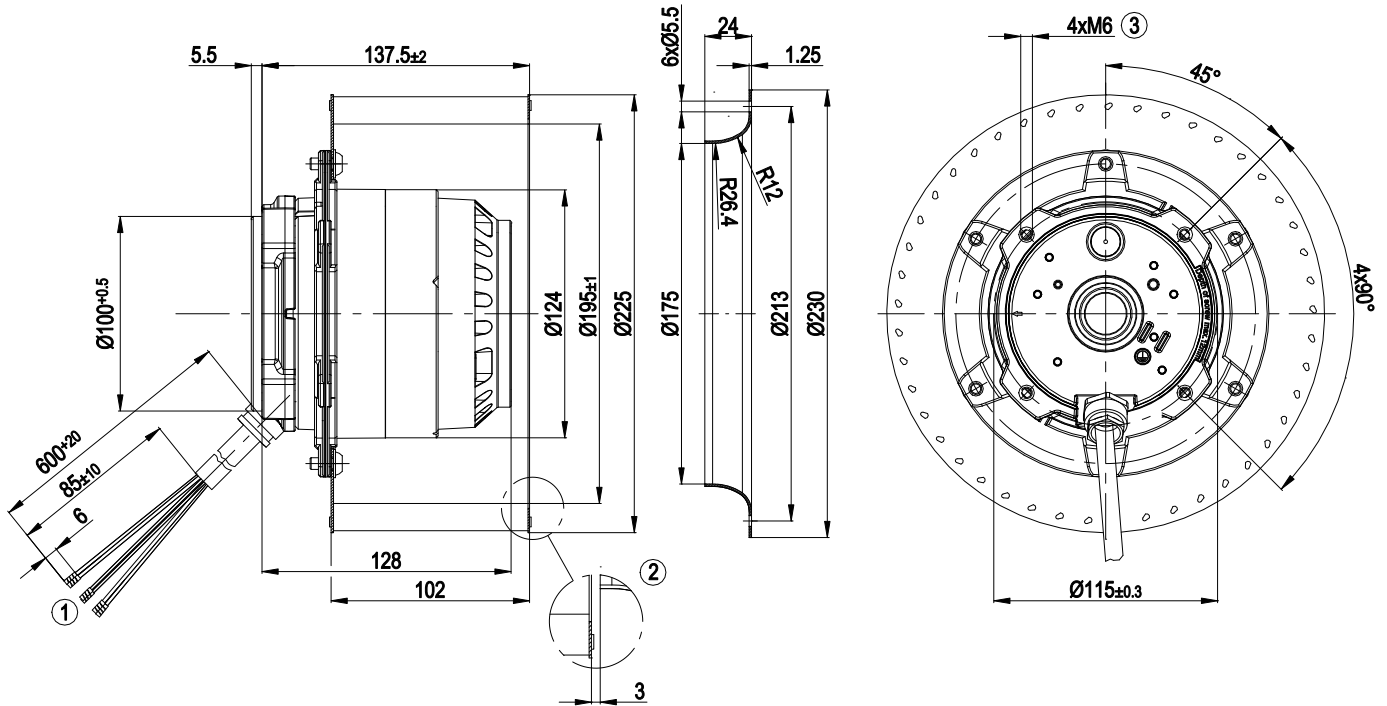

1	Cable silicone, 6 x crimped splices
2	Accessory part: Inlet ring 09605-2-4013 not included in scope of delivery
3	Max. clearance for screw 12 mm



Connection diagram

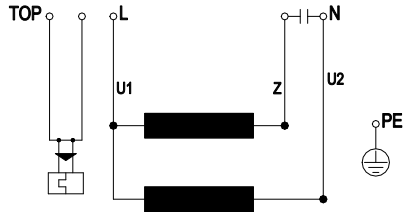

TOP	2x gray	U1	blue	Z	brown
U2	black	PE	green/yellow		



Curves: Air performance 50 Hz

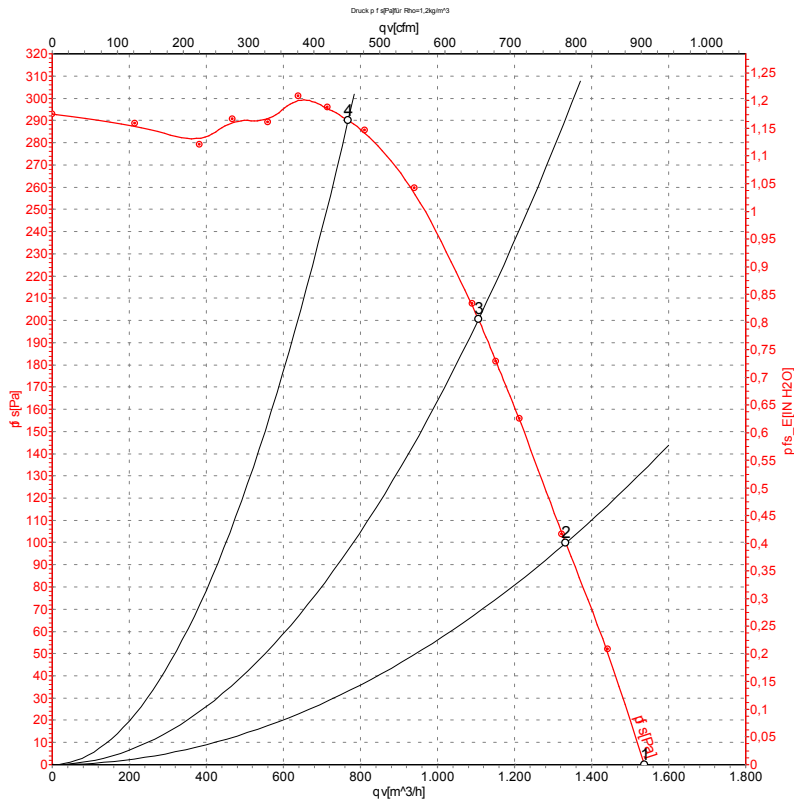

Measurement: LU-54520-1

Air performance measured according to ISO 5801 installation category A. For detailed information on the measurement setup, contact ebmpapst. Intake sound level: Sound power level according to ISO 13347 / sound pressure level measured at 1 m distance from fan axis. The values given are valid under the specified measuring conditions and may vary due to conditions of installation. For deviations from the standard configuration, the parameters have to be checked on the installed unit.

Measured values

	U	f	n	P _e	I	q _v	P _{fs}	q _v	P _{fs}
	V	Hz	min ⁻¹	W	A	m ³ /h	Pa	cfm	inH ₂ O
1	230	50	1330	395	1.98	1535	0	905	0.00
2	230	50	1370	340	1.76	1335	100	785	0.40
3	230	50	1400	290	1.58	1105	200	650	0.80
4	230	50	1435	225	1.39	770	290	450	1.16

U = Power supply · f = Frequency · n = Speed (rpm) · P_e = Power consumption · I = Current draw · q_v = Air flow · P_{fs} = Pressure increase



Curves: Air performance 60 Hz

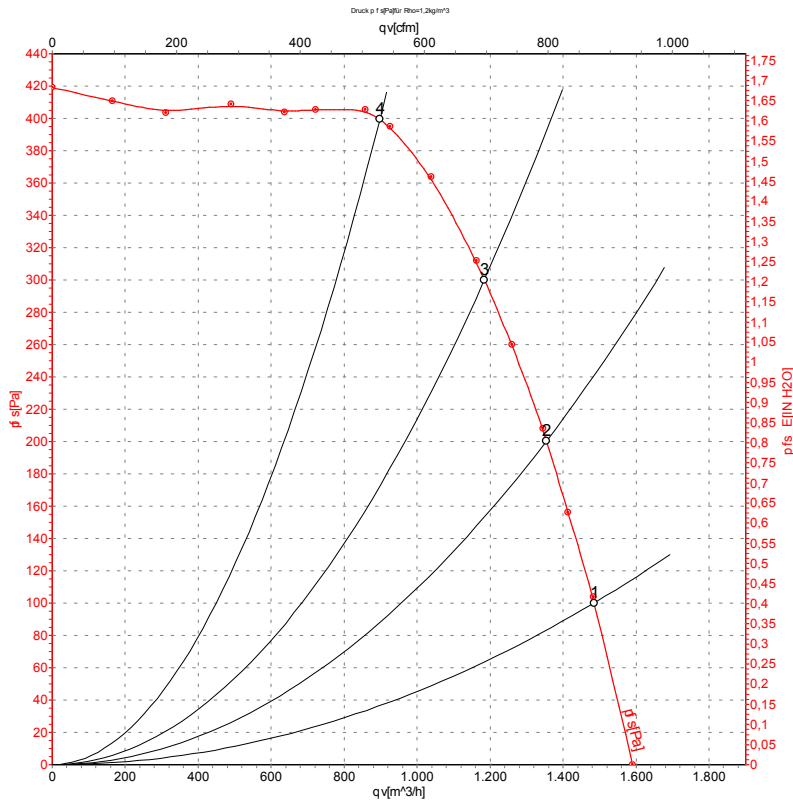

Measurement: LU-54523-1

Air performance measured according to ISO 5801 installation category A. For detailed information on the measurement setup, contact ebm-papst. Intake sound level: Sound power level according to ISO 13347 / sound pressure level measured at 1 m distance from fan axis. The values given are valid under the specified measuring conditions and may vary due to conditions of installation. For deviations from the standard configuration, the parameters have to be checked on the installed unit.

Measured values

	U	f	n	P _e	I	q _v	P _{fs}	q _v	P _{fs}
	V	Hz	min ⁻¹	W	A	m ³ /h	Pa	cfm	inH ₂ O
1	230	60	1500	500	2.30	1485	100	875	0.40
2	230	60	1560	443	2.00	1355	200	795	0.80
3	230	60	1615	383	1.71	1185	300	695	1.20
4	230	60	1680	303	1.35	900	400	530	1.61

U = Power supply · f = Frequency · n = Speed (rpm) · P_e = Power consumption · I = Current draw · q_v = Air flow · P_{fs} = Pressure increase

