

R4E225-AI01-09 ebmpapst Datasheet

sales@fansco.com

www.fansco.com

Limited partnership · Headquarters Mulfingen

Amtsgericht (court of registration) Stuttgart · HRA 590344

General partner Elektrobau Mulfingen GmbH · Headquarters Mulfingen

Amtsgericht (court of registration) Stuttgart · HRB 590142

Nominal data

Type	R4E225-AI01-09			
Motor	M4E068-CF			
Phase		1~	1~	1~
Nominal voltage	VAC	230	230	230
Frequency	Hz	50	60	60
Method of obtaining data		fa	fa	fa
Valid for approval/standard		CE	UL 2111	CE
Speed (rpm)	min ⁻¹	1430	1700	1700
Power consumption	W	40	50	45
Current draw	A	0.2	0.22	0.2
Capacitor	µF	1.5	1.5	1.5
Capacitor voltage	VDB	450	450	450
Capacitor standard		S0 (CE)	UL	
Min. back pressure	Pa	0	0	0
Min. back pressure	in. wg	0	0	0
Min. ambient temperature	°C	-25	-25	-25
Max. ambient temperature	°C	50	50	50

ml = Max. load · me = Max. efficiency · fa = Free air · cs = Customer specification · ce = Customer equipment
Subject to change



Technical description

Weight	1.9 kg
Size	225 mm
Motor size	68
Impeller material	PA6 plastic, glass-fiber reinforced
Number of blades	11
Direction of rotation	Clockwise, viewed toward rotor
Degree of protection	IP44; installation- and position-dependent
Insulation class	"B"
Moisture (F) / Environmental (H) protection class	H0 - dry environment
Max. permitted ambient temp. for motor (transport/storage)	+ 80 °C
Min. permitted ambient temp. for motor (transport/storage)	- 40 °C
Installation position	Any
Condensation drainage holes	None
Mode	S1
Motor bearing	Ball bearing
Touch current according to IEC 60990 (measuring circuit Fig. 4, TN system)	< 0.75 mA
Motor protection	Thermal overload protector (TOP) internally connected
With cable	Variable
Protection class	I (with customer connection of protective earth)
Conformity with standards	EN 60335-1; CE
Approval	CSA C22.2 No. 77; CCC; UL 1004-3

Product drawing

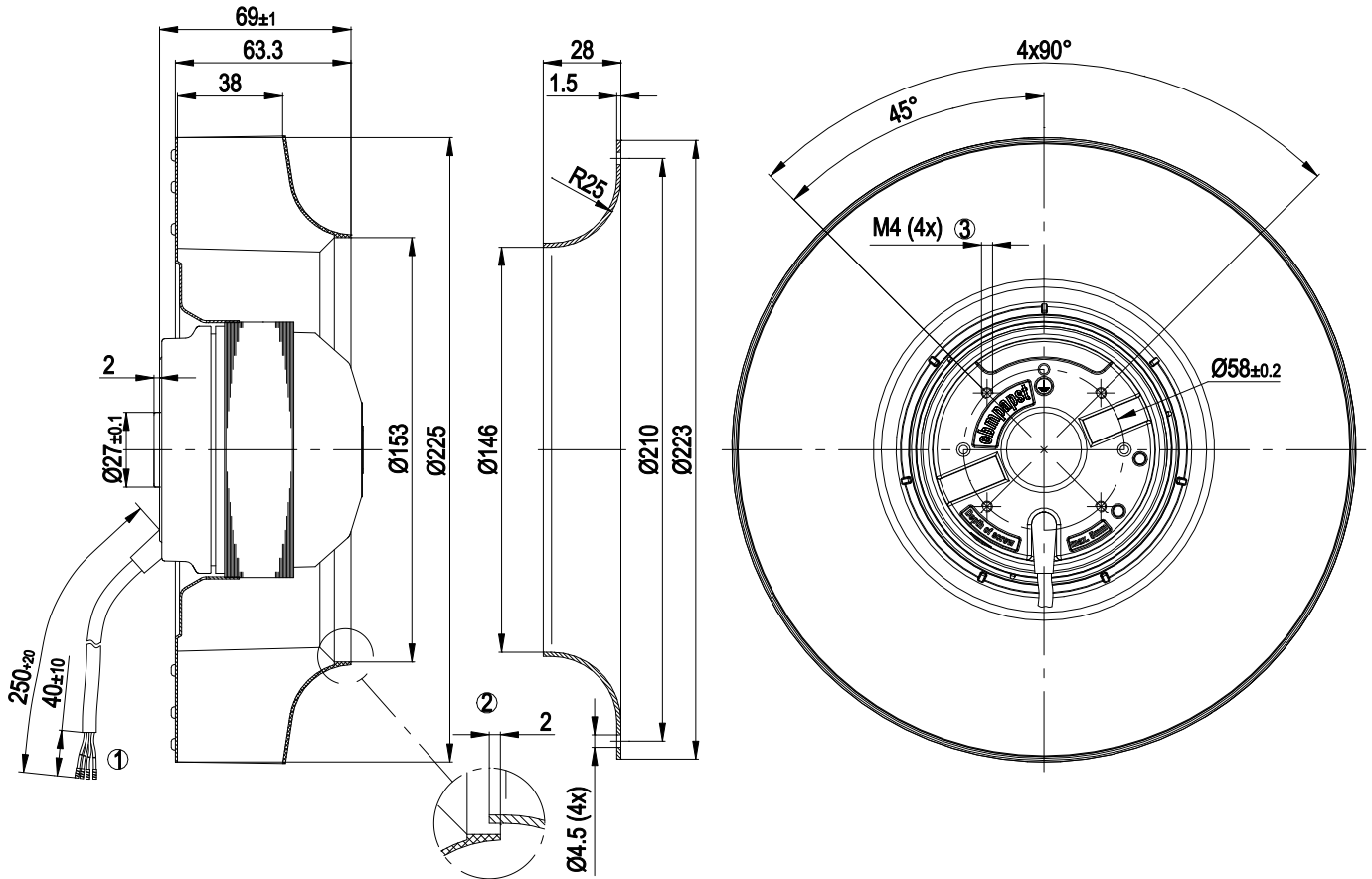

- | | |
|---|---|
| 1 | Cable PVC 4G AWG20, 4x crimped splices |
| 2 | Accessory part: inlet ring 96358-2-4013 not included in scope of delivery |
| 3 | Max. clearance for screw 5 mm |

Connection diagram



U1	blue	Z	brown	U2	black
PE	green/yellow				



Curves: Air performance 50 Hz

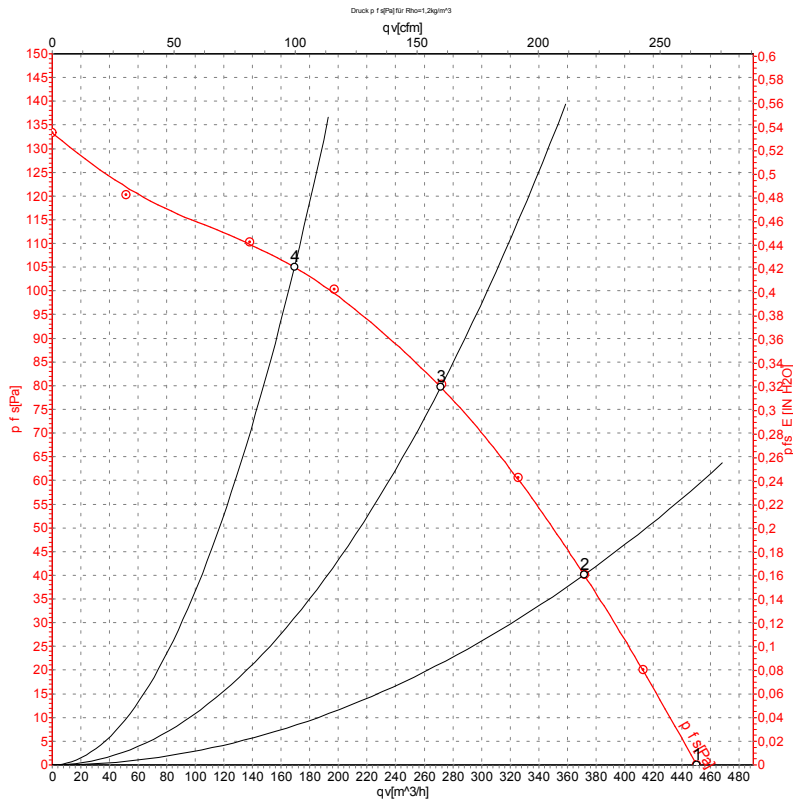

Measurement: LU-30980-1

Air performance measured according to ISO 5801 installation category A. For detailed information on the measurement setup, contact ebm-papst. Intake sound level: Sound power level according to ISO 13347 / sound pressure level measured at 1 m distance from fan axis. The values given are valid under the specified measuring conditions and may vary due to conditions of installation. For deviations from the standard configuration, the parameters have to be checked on the installed unit.

Measured values

	U	f	n	P _e	I	q _v	P _{is}	q _v	P _{is}
	V	Hz	min ⁻¹	W	A	m ³ /h	Pa	cfm	in. wg
1	230	50	1430	40	0.20	450	0	265	0.00
2	230	50	1430	40	0.20	370	40	220	0.16
3	230	50	1425	41	0.20	270	80	160	0.32
4	230	50	1425	41	0.20	170	105	100	0.42

U = Voltage · f = Frequency · n = Speed (rpm) · P_e = Power consumption · I = Current draw · q_v = Air flow · p_{is} = Pressure increase



Curves: Air performance 60 Hz

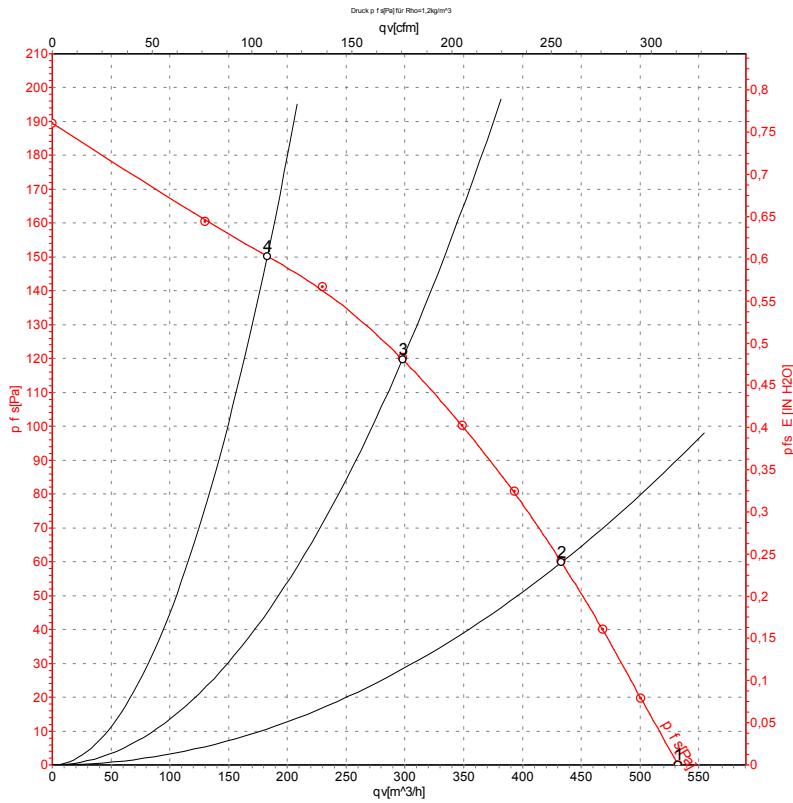

Measurement: LU-30981-1

Air performance measured according to ISO 5801 installation category A. For detailed information on the measurement setup, contact ebm-papst. Intake sound level: Sound power level according to ISO 13347 / sound pressure level measured at 1 m distance from fan axis. The values given are valid under the specified measuring conditions and may vary due to conditions of installation. For deviations from the standard configuration, the parameters have to be checked on the installed unit.

Measured values

	U	f	n	P _e	I	q _v	p _{fs}	q _v	p _{fs}
	V	Hz	min ⁻¹	W	A	m³/h	Pa	cfm	in. wg
1	230	60	1700	45	0.20	530	0	315	0.00
2	230	60	1690	47	0.20	435	60	255	0.24
3	230	60	1680	49	0.21	300	120	175	0.48
4	230	60	1690	47	0.21	185	150	110	0.60

U = Voltage · f = Frequency · n = Speed (rpm) · P_e = Power consumption · I = Current draw · q_v = Air flow · p_{fs} = Pressure increase

