

R4E160-AB08-30 ebmpapst Datasheet

sales@fansco.com

www.fansco.com

Limited partnership · Headquarters Mulfingen

Amtsgericht (court of registration) Stuttgart · HRA 590344

General partner Elektrobau Mulfingen GmbH · Headquarters Mulfingen

Amtsgericht (court of registration) Stuttgart · HRB 590142

Nominal data

Type	R4E160-AB08-30		
Motor	M4E068-CF		
Phase		1~	1~
Nominal voltage	VAC	230	230
Frequency	Hz	50	60
Method of obtaining data		ml	ml
Valid for approval/standard		CE	CE
Speed (rpm)	min ⁻¹	1250	1480
Power consumption	W	55	57
Current draw	A	0.25	0.26
Capacitor	µF	1	1
Capacitor voltage	VDB	400	400
Capacitor standard		P0 (CE)	P0 (CE)
Min. back pressure	Pa	40	110
Min. back pressure	inH ₂ O	0.16	0.44
Min. ambient temperature	°C	-25	-25
Max. ambient temperature	°C	65	65

ml = Max. load · me = Max. efficiency · fa = Free air · cs = Customer specification · ce = Customer equipment
Subject to change



Technical description

Weight	1.7 kg
Fan size	160 mm
Rotor surface	Unpainted
Impeller material	Sheet steel, galvanized
Direction of rotation	Clockwise, viewed toward rotor
Degree of protection	IP44; installation- and position-dependent as per EN 60034-5
Insulation class	"B"
Moisture (F) / Environmental (H) protection class	F1-1
Max. permitted ambient temp. for motor (transport/storage)	+ 80 °C
Min. permitted ambient temp. for motor (transport/storage)	- 40 °C
Installation position	Shaft horizontal or rotor on bottom; rotor on top on request
Condensation drainage holes	On rotor side
Mode	S1
Motor bearing	Ball bearing
Touch current according to IEC 60990 (measuring circuit Fig. 4, TN system)	< 0.75 mA
Motor protection	Temperature limiter manual reset
With cable	Variable
Protection class	I (with customer connection of protective earth)
Conformity with standards	EN 60335-1; CE

Product drawing

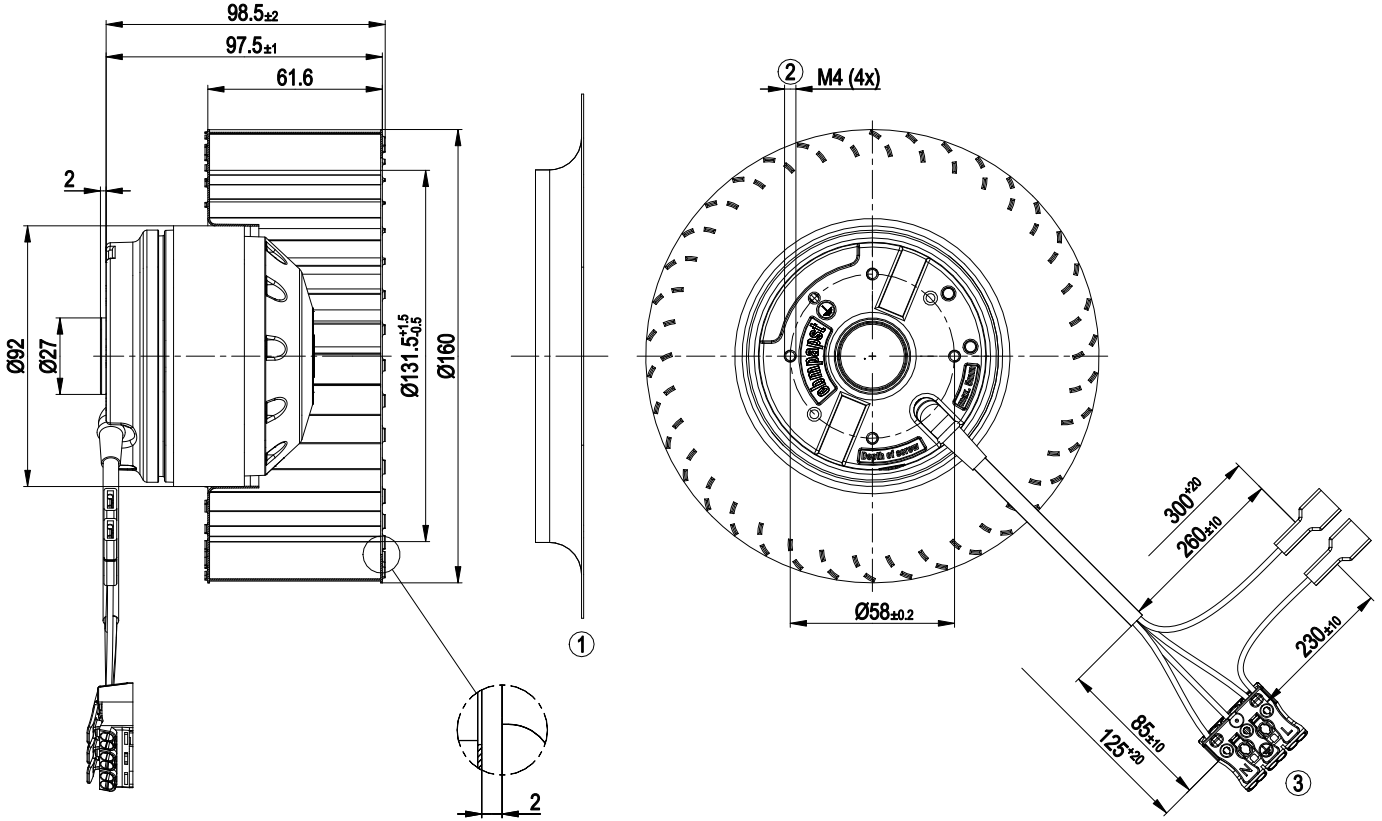

1	Accessory part: inlet ring 09588-2-4013 not included in scope of delivery
2	Max. clearance for screw 5 mm
3	Cable PVC 4G 0.5 mm ² , 1x terminal strip Adels Contact 040G13B1, 1x cable PVC AWG20, 2x flat push-on receptacle 6.3 - 0.8, 2x insulating sleeve SES 105-01

Accessory part

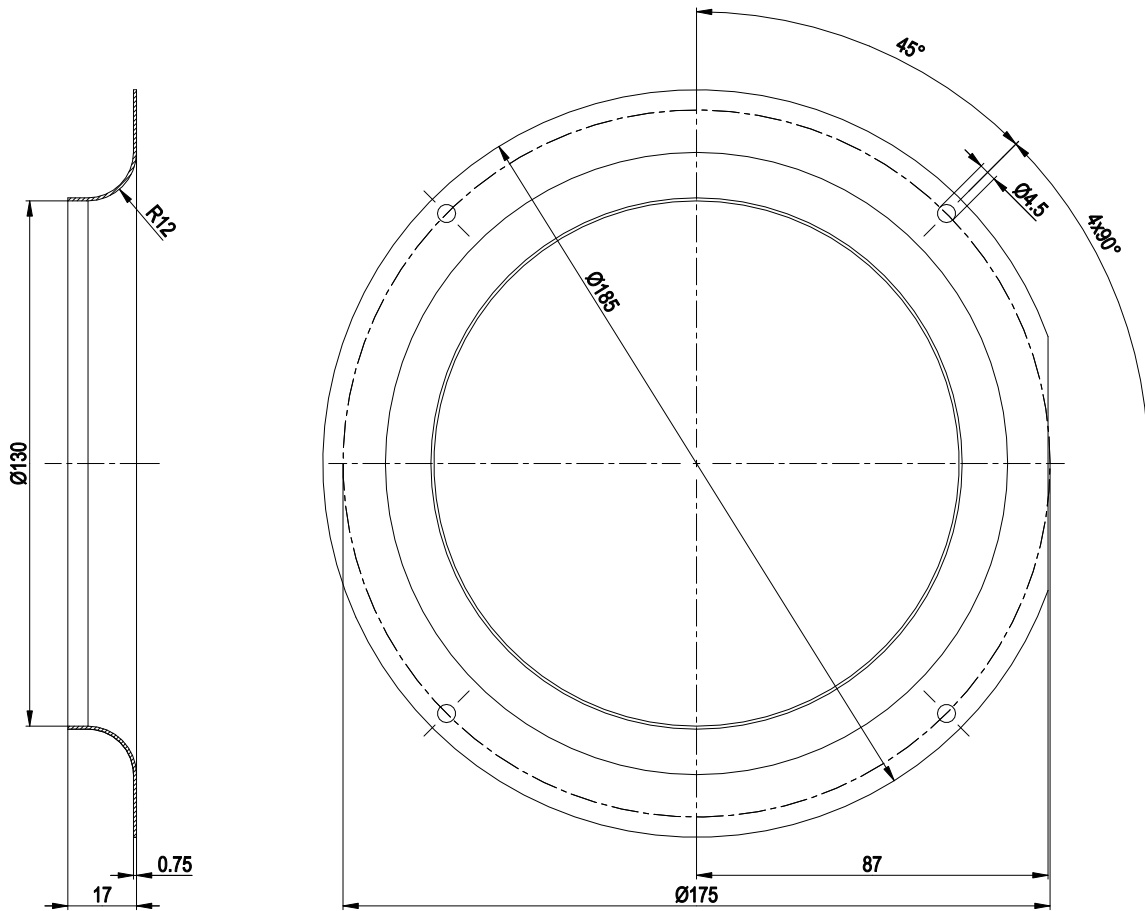

Accessory part: inlet ring 09588-2-4013 not included in scope of delivery

Connection diagram

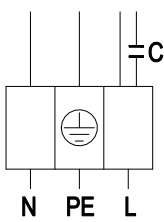

L	black	N	blue	PE	green/yellow
---	-------	---	------	----	--------------



Curves: Air performance 50 Hz

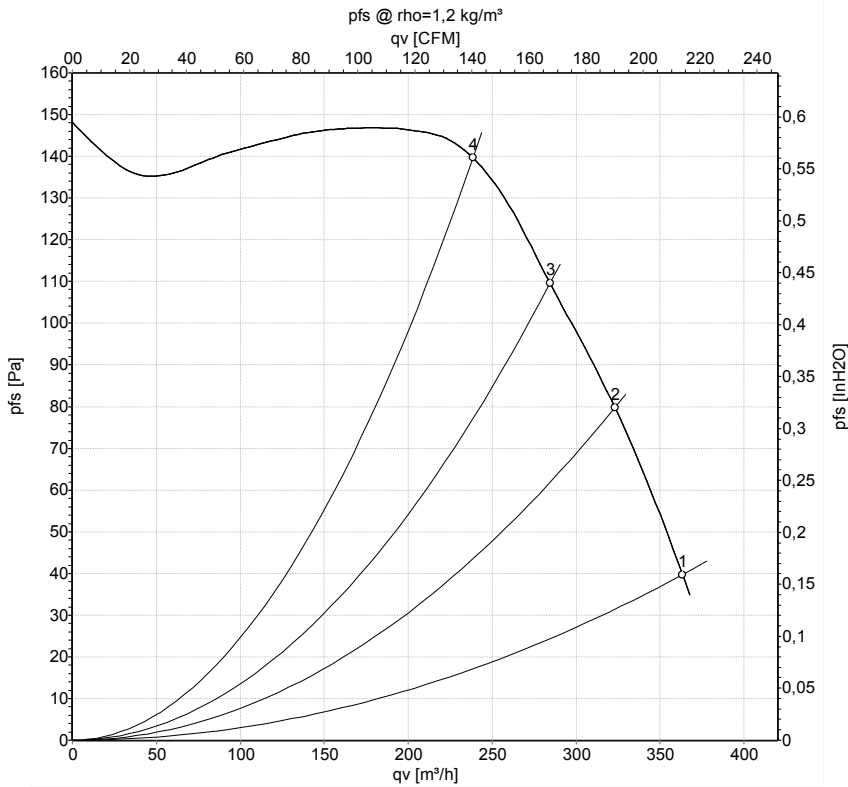

Measurement: LU-160806-1

Air performance measured according to ISO 5801 installation category A. For detailed information on the measurement setup, contact ebm-papst. Intake sound level: Sound power level according to ISO 13347 / sound pressure level measured at 1 m distance from fan axis. The values given are valid under the specified measuring conditions and may vary due to conditions of installation. For deviations from the standard configuration, the parameters have to be checked on the installed unit.

Measured values

	U	f	n	P _e	I	LpA _{in}	LwA _{in}	qv	p _{fs}	qv	p _{fs}
	V	Hz	min ⁻¹	W	A	dB(A)	dB(A)	m³/h	Pa	CFM	inH2O
1	230	50	1250	55	0.25	55	62	365	40	215	0.16
2	230	50	1325	46	0.21	54	62	325	80	190	0.32
3	230	50	1360	41	0.19	54	61	285	110	165	0.44
4	230	50	1390	37	0.18	52	60	240	140	140	0.56

U = Power supply · f = Frequency · n = Speed (rpm) · P_e = Power consumption · I = Current draw · LpA_{in} = Sound pressure level intake side · LwA_{in} = Sound power level intake side
 qv = Air flow · p_{fs} = Pressure increase



Curves: Air performance 60 Hz

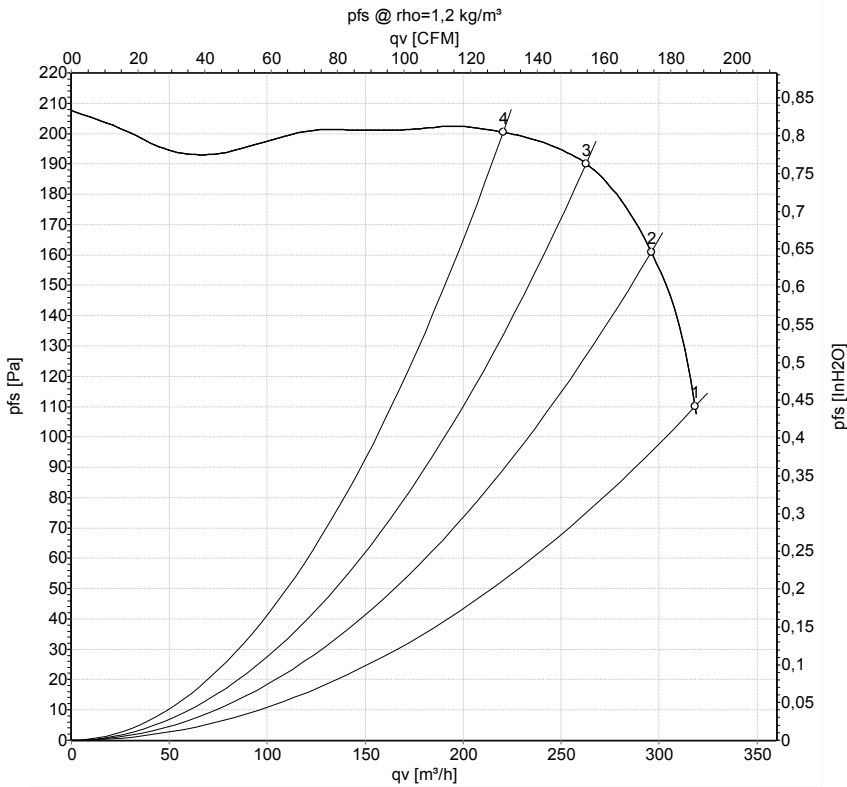

Measurement: LU-161680-1

Air performance measured according to ISO 5801 installation category A. For detailed information on the measurement setup, contact ebm-papst. Intake sound level: Sound power level according to ISO 13347 / sound pressure level measured at 1 m distance from fan axis. The values given are valid under the specified measuring conditions and may vary due to conditions of installation. For deviations from the standard configuration, the parameters have to be checked on the installed unit.

Measured values

	U	f	n	P _e	I	LpA _{in}	LwA _{in}	qv	p _{fs}	qv	p _{fs}
	V	Hz	min ⁻¹	W	A	dB(A)	dB(A)	m ³ /h	Pa	CFM	inH2O
1	230	60	1480	57	0.26	54	61	320	110	185	0.44
2	230	60	1540	52	0.23	56	63	295	160	175	0.64
3	230	60	1595	47	0.20	56	63	265	190	155	0.76
4	230	60	1645	42	0.18	56	63	220	200	130	0.80

U = Power supply · f = Frequency · n = Speed (rpm) · P_e = Power consumption · I = Current draw · LpA_{in} = Sound pressure level intake side · LwA_{in} = Sound power level intake side
 qv = Air flow · p_{fs} = Pressure increase

