

R4D500-PB05-05 ebmpapst Datasheet

sales@fansco.com

www.fansco.com

Limited partnership · Headquarters Mulfingen

Amtsgericht (court of registration) Stuttgart · HRA 590344

General partner Elektrobau Mulfingen GmbH · Headquarters Mulfingen

Amtsgericht (court of registration) Stuttgart · HRB 590142

## Nominal data

Type	R4D500-PB05-05				
Motor	M4D138-LA				
Phase		3~	3~	3~	3~
Nominal voltage	VAC	230	277	400	480
Wiring		$\Delta$	$\Delta$	Y	Y
Frequency	Hz	50	60	50	60
Method of obtaining data		ml	ml	ml	ml
Valid for approval/standard		CE	CE	CE	CE
Speed (rpm)	min <sup>-1</sup>	1400	1650	1400	1650
Power consumption	W	1500	2450	1500	2450
Current draw	A	5.5	6.8	3.2	3.9
Min. back pressure	Pa	0	0	0	0
Min. back pressure	inH <sub>2</sub> O	0	0	0	0
Min. ambient temperature	°C	-25	-25	-25	-25
Max. ambient temperature	°C	90	70	90	60
Starting current	A	9.8	11.0	5.7	6.3

ml = Max. load · me = Max. efficiency · fa = Free air · cs = Customer specification · ce = Customer equipment  
Subject to change

## Data according to Commission Regulation (EU) 327/2011

		Actual	Req. 2015		
01 Overall efficiency $\eta_{es}$	%	58.8	53.2	09 Power consumption $P_e$	kW 1.46
02 Measurement category	A			09 Air flow $q_v$	m <sup>3</sup> /h 5860
03 Efficiency category	Static			09 Pressure increase $p_{fs}$	Pa 529
04 Efficiency grade N	67.6	62		10 Speed (rpm) n	min <sup>-1</sup> 1410
05 Variable speed drive	No			11 Specific ratio*	1.01

Data obtained at optimum efficiency level.  
The ErP data is determined using a motor-impeller combination in a standardized measurement setup.

\* Specific ratio =  $1 + p_{fs} / 100\,000\text{ Pa}$ 

LU-175351



## Technical description

Weight	25.5 kg
Fan size	500 mm
Rotor surface	Cast in aluminum
Impeller material	Sheet aluminum
Number of blades	5
Direction of rotation	Clockwise, viewed toward rotor
Degree of protection	IP54
Insulation class	"F"
Moisture (F) / Environmental (H) protection class	H2
Ambient temperature note	Occasional start-up between -40°C and -25°C is permissible. For continuous operation at temperatures below -25°C (e.g. refrigeration applications) we recommend our fan design with special low-temperature bearings.
Max. permitted ambient temp. for motor (transport/storage)	+ 80 °C
Min. permitted ambient temp. for motor (transport/storage)	- 40 °C
Installation position	Any
Condensation drainage holes	On rotor and stator sides
Mode	S1
Motor bearing	Ball bearing
Touch current according to IEC 60990 (measuring circuit Fig. 4, TN system)	<= 3.5 mA
Electrical hookup	Via terminal box
Motor protection	Thermal overload protector (TOP) with basic insulation
Protection class	I (with customer connection of protective earth)
Conformity with standards	EN 61800-5-1; EN 60034-1 (2010); CE
Approval	CSA C22.2 No. 100; UL 1004-1; EAC

Product drawing

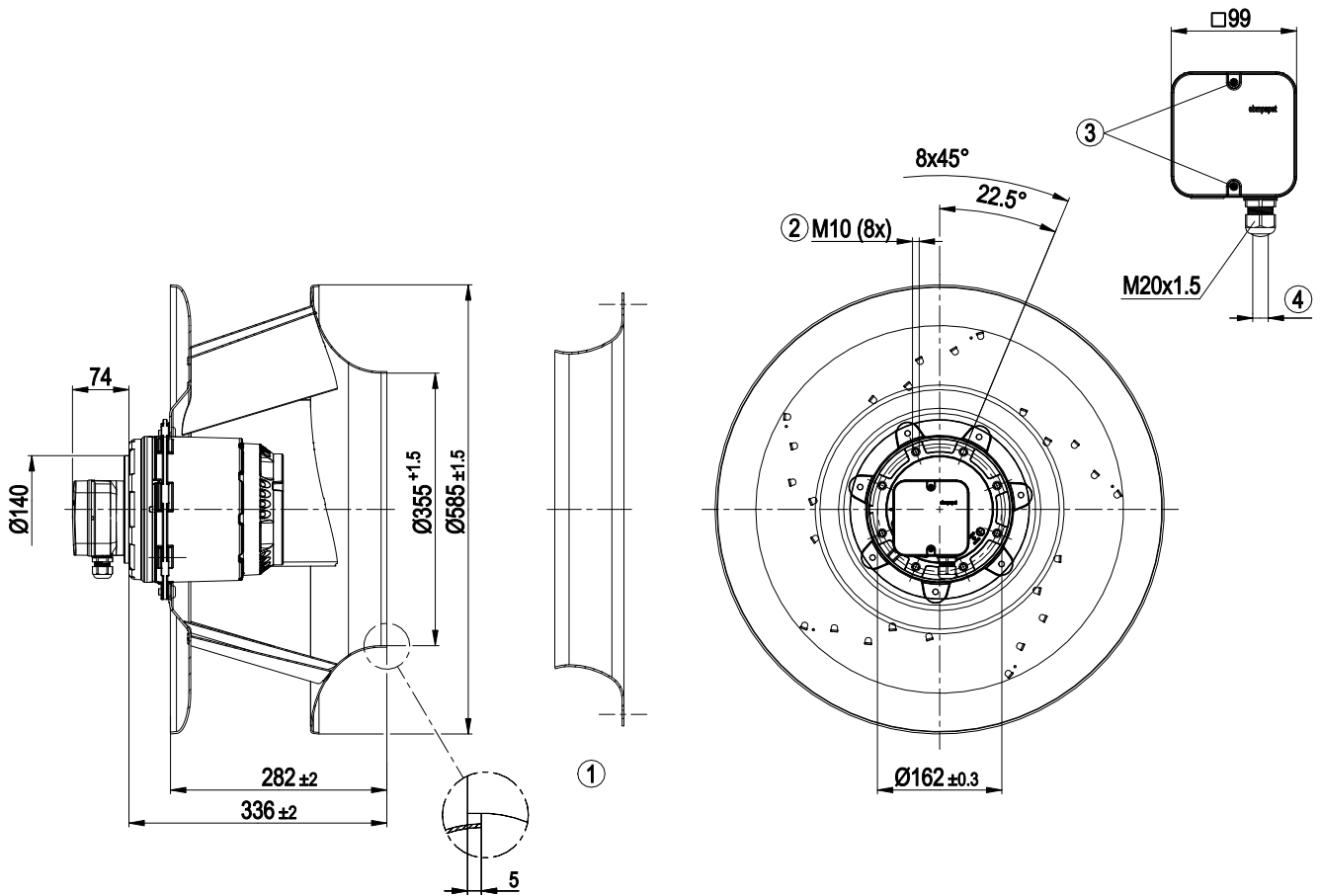

- |   |   |
|---|---|
| 1 | Accessory part: inlet ring 63072-2-4013 not included in scope of delivery |
| 2 | Max. clearance for screw 18 mm  |
| 3 | Tightening torque $1.5 \pm 0.2$ Nm  |
| 4 | Cable diameter min. 7 mm, max. 14 mm, tightening torque $2 \pm 0.3$ Nm    |



# AC centrifugal fan

backward-curved, single-intake

## Accessory part

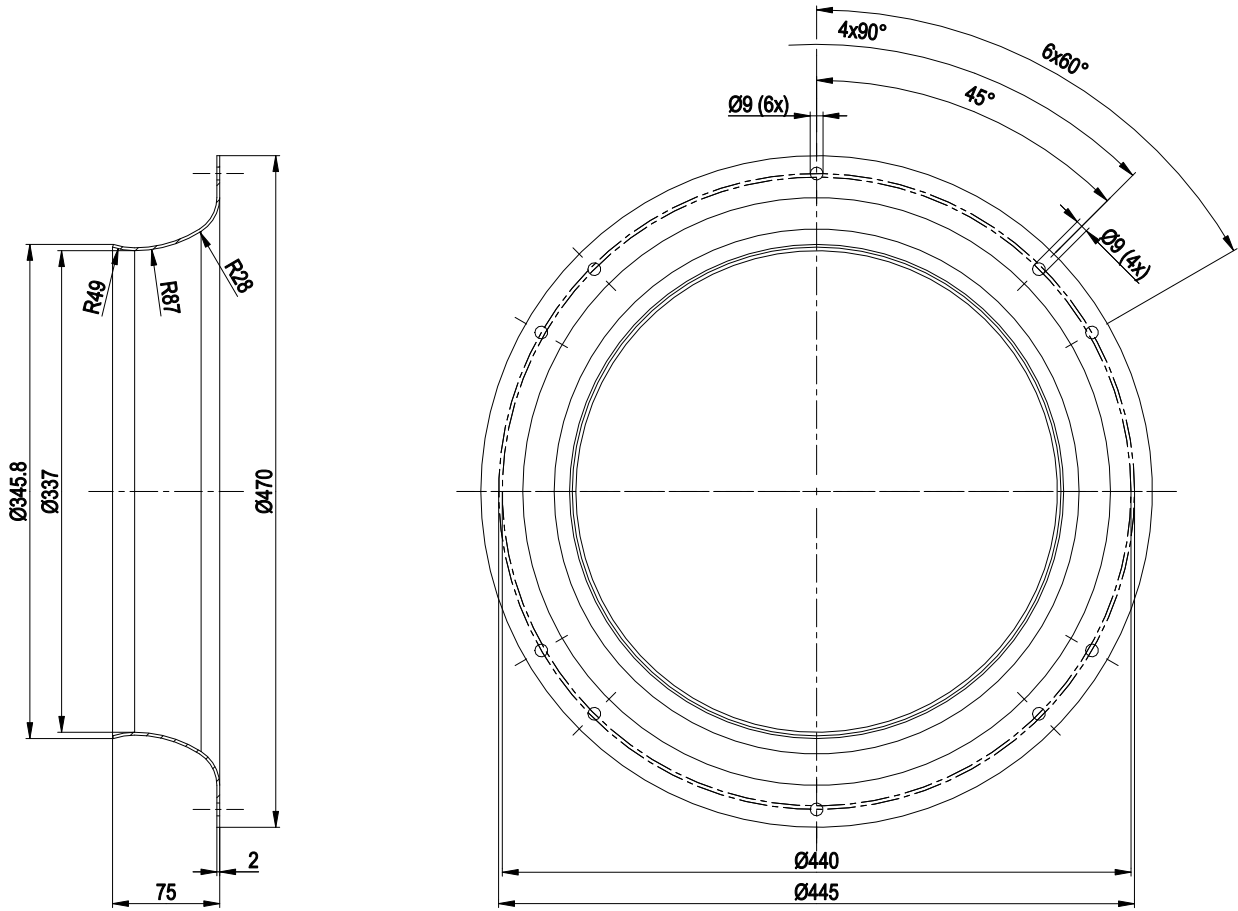

inlet ring 63072-2-4013 not included in scope of delivery



# AC centrifugal fan

backward-curved, single-intake

## Connection diagram

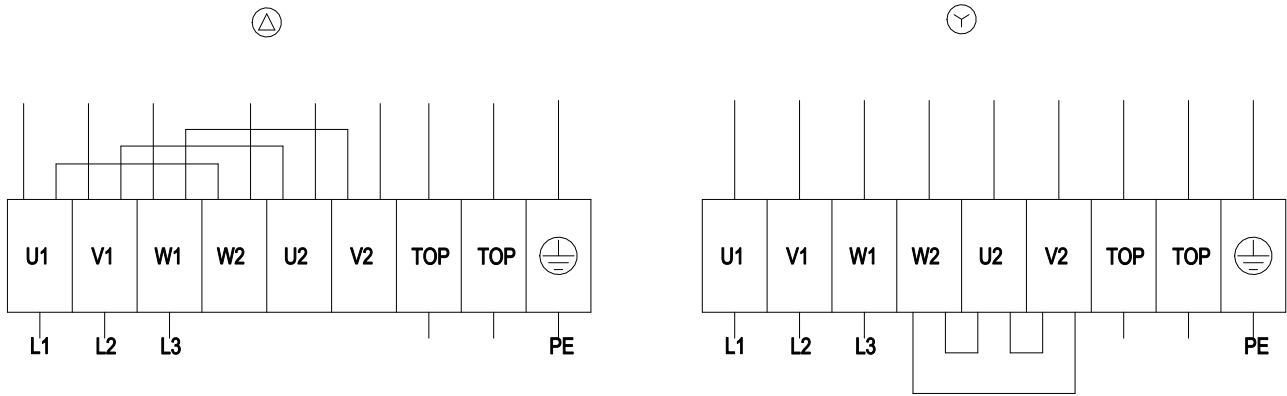

Δ	Delta connection	Y	Star connection	L1	= U1 = black
L2	= V1 = blue	L3	= W1 = brown	W2	yellow
U2	green	V2	white	TOP	2x gray
PE	green/yellow				



## Curves: Air performance 50 Hz

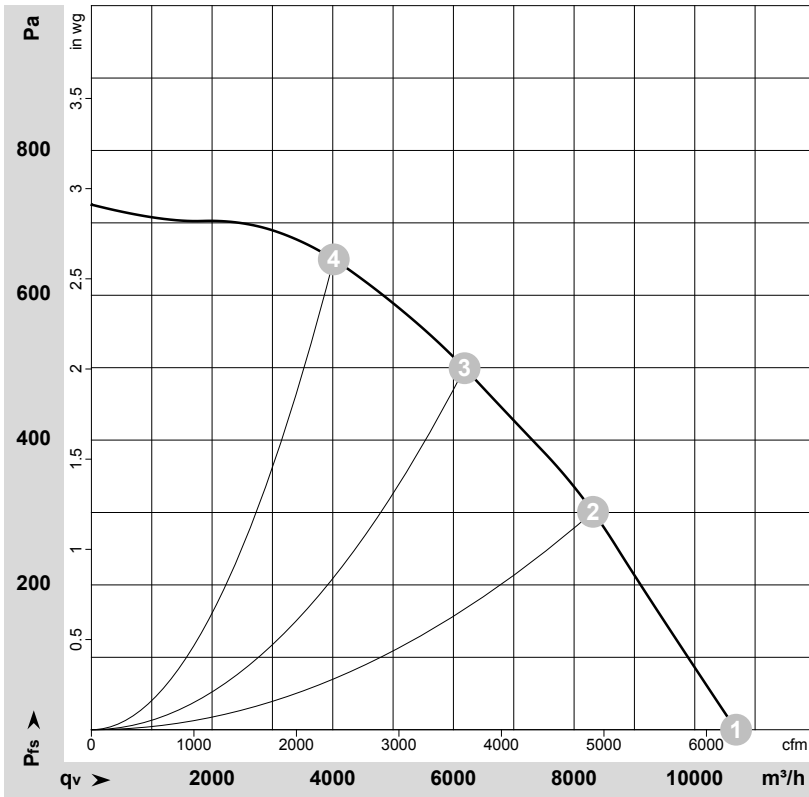

$\rho = 1.15 \text{ kg/m}^3 \pm 2 \%$

Measurement: LU-175351-1

Air performance measured according to ISO 5801 installation category A. For detailed information on the measurement setup, contact ebmpapst. Intake sound level: Sound power level according to ISO 13347 / sound pressure level measured at 1 m distance from fan axis. The values given are valid under the specified measuring conditions and may vary due to conditions of installation. For deviations from the standard configuration, the parameters have to be checked on the installed unit.

## Measured values

	Wired	U	f	n	$P_e$	I	$LpA_{in}$	$LwA_{in}$	$LwA_{out}$	$q_v$	$p_{fs}$	$q_v$	$p_{fs}$
		V	Hz	$\text{min}^{-1}$	W	A	dB(A)	dB(A)	dB(A)	$\text{m}^3/\text{h}$	Pa	cfm	inH2O
1	Y	400	50	1440	1020	2.71	86	94	95	10685	0	6290	0.00
2	Y	400	50	1415	1368	3.09	75	83	86	8315	300	4895	1.20
3	Y	400	50	1400	1500	3.20	70	77	81	6185	500	3640	2.01
4	Y	400	50	1415	1403	3.11	71	77	82	4015	650	2365	2.61

Wired = Wiring · U = Power supply · f = Frequency · n = Speed (rpm) ·  $P_e$  = Power consumption · I = Current draw ·  $LpA_{in}$  = Sound pressure level intake side ·  $LwA_{in}$  = Sound power level intake side  
 $LwA_{out}$  = Sound power level outlet side ·  $q_v$  = Air flow ·  $p_{fs}$  = Pressure increase



## Curves: Air performance 60 Hz

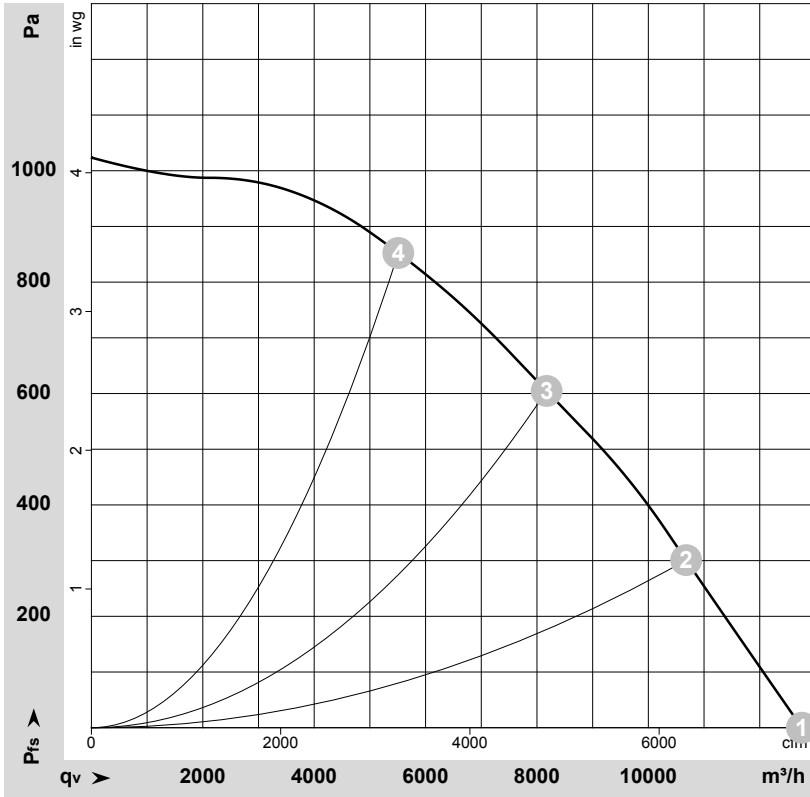

$\rho = 1.15 \text{ kg/m}^3 \pm 2 \%$

Measurement: LU-175466-1

Air performance measured according to ISO 5801 installation category A. For detailed information on the measurement setup, contact ebm-papst. Intake sound level: Sound power level according to ISO 13347 / sound pressure level measured at 1 m distance from fan axis. The values given are valid under the specified measuring conditions and may vary due to conditions of installation. For deviations from the standard configuration, the parameters have to be checked on the installed unit.

## Measured values

	Wired	U	f	n	P <sub>e</sub>	I	LpA <sub>in</sub>	LwA <sub>in</sub>	LwA <sub>out</sub>	q <sub>v</sub>	p <sub>fs</sub>	q <sub>v</sub>	p <sub>fs</sub>
		V	Hz	min <sup>-1</sup>	W	A	dB(A)	dB(A)	dB(A)	m <sup>3</sup> /h	Pa	cfm	inH <sub>2</sub> O
1	Y	480	60	1715	1660	3.11	92	98	99	12760	0	7510	0.00
2	Y	480	60	1690	2072	3.53	84	91	93	10680	300	6285	1.20
3	Y	480	60	1650	2450	3.90	76	83	86	8175	600	4810	2.41
4	Y	480	60	1665	2393	3.88	74	80	85	5510	850	3245	3.41

Wired = Wiring · U = Power supply · f = Frequency · n = Speed (rpm) · P<sub>e</sub> = Power consumption · I = Current draw · LpA<sub>in</sub> = Sound pressure level intake side · LwA<sub>in</sub> = Sound power level intake side  
 LwA<sub>out</sub> = Sound power level outlet side · q<sub>v</sub> = Air flow · p<sub>fs</sub> = Pressure increase

