

R4D450-FH03-01 ebmpapst Datasheet

sales@fansco.com

www.fansco.com

Limited partnership · Headquarters Mulfingen

Amtsgericht (court of registration) Stuttgart · HRA 590344

General partner Elektrobau Mulfingen GmbH · Headquarters Mulfingen

Amtsgericht (court of registration) Stuttgart · HRB 590142

Nominal data

Type	R4D450-FH03-01				
Motor	M4D110-IA				
Phase		3~	3~	3~	3~
Nominal voltage	VAC	230	277	400	480
Wiring		Δ	Δ	Y	Y
Frequency	Hz	50	60	50	60
Method of obtaining data		ml	ml	ml	ml
Valid for approval/standard		CE	CE	CE	CE
Speed (rpm)	min ⁻¹	1420	1680	1420	1680
Power consumption	W	720	1190	720	1190
Current draw	A	3.3	3.8	1.9	2.2
Min. back pressure	Pa	0	0	0	0
Min. back pressure	in. wg	0	0	0	0
Min. ambient temperature	°C	-40	-40	-40	-40
Max. ambient temperature	°C	40	40	40	40
Starting current	A	16.5	19	9.5	11

ml = Max. load · me = Max. efficiency · fa = Free air · cs = Customer specification · ce = Customer equipment
Subject to change

Data according to Commission Regulation (EU) 327/2011 (EN 17166)

		Actual	Req. 2015			
01 Overall efficiency η_{es}	%	58	50	09 Power consumption P_e	kW	0.71
02 Measurement category		A		09 Air flow q_v	m ³ /h	4555
03 Efficiency category		Static		09 Pressure increase p_{fs}	Pa	331
04 Efficiency grade N		70	62	10 Speed (rpm) n	min ⁻¹	1420
05 Variable speed drive		No		11 Specific ratio*		1.00

Data obtained at optimum efficiency level.

* Specific ratio = $1 + p_{fs} / 100\,000\text{ Pa}$

LU-208311

The efficiency values displayed for achieving conformity with the Ecodesign Regulation EU 327/2011 has been reached with defined air duct components (e.g. inlet rings).
The dimensions must be requested from ebm-papst. If other air conduction geometries are used on the installation side, the ebm-papst evaluation loses its validity/the conformity must be confirmed again.
The product does not fall within the scope of Regulation (EU) 2019/1781 due to the exception specified in Article 2 (2a) (motors completely integrated into a product).



Technical description

Weight	13.2 kg
Size	450 mm
Motor size	110
Rotor surface	Cast in aluminum
Impeller material	PP plastic
Number of blades	6
Direction of rotation	Clockwise, viewed toward rotor
Degree of protection	IP54
Insulation class	"F"
Moisture (F) / Environmental (H) protection class	H2
Ambient temperature note	Occasional start-up at temperatures between -40°C and -25°C is permitted. For continuous operation at ambient temperatures below -25°C (such as refrigeration applications), use must be made of a fan design with special low-temperature bearings.
Max. permitted ambient temp. for motor (transport/storage)	+80 °C
Min. permitted ambient temp. for motor (transport/storage)	-40 °C
Installation position	Shaft horizontal or rotor on bottom; rotor on top on request
Condensation drainage holes	On rotor side
Mode	S1
Motor bearing	Ball bearing
Touch current according to IEC 60990 (measuring circuit Fig. 4, TN system)	<= 3.5 mA
Motor protection	Thermal overload protector (TOP) with basic insulation
Protection class assignment	I; If a protective earth is connected by the customer This component for installation may have several local protection classes. This information relates to this component's basic design. The final protection class is based on the component's intended installation and connection.
Conformity with standards	EN 60034-1; CE
Approval	VDE; CSA C22.2 No. 100; EAC; UL 1004-1

Product drawing

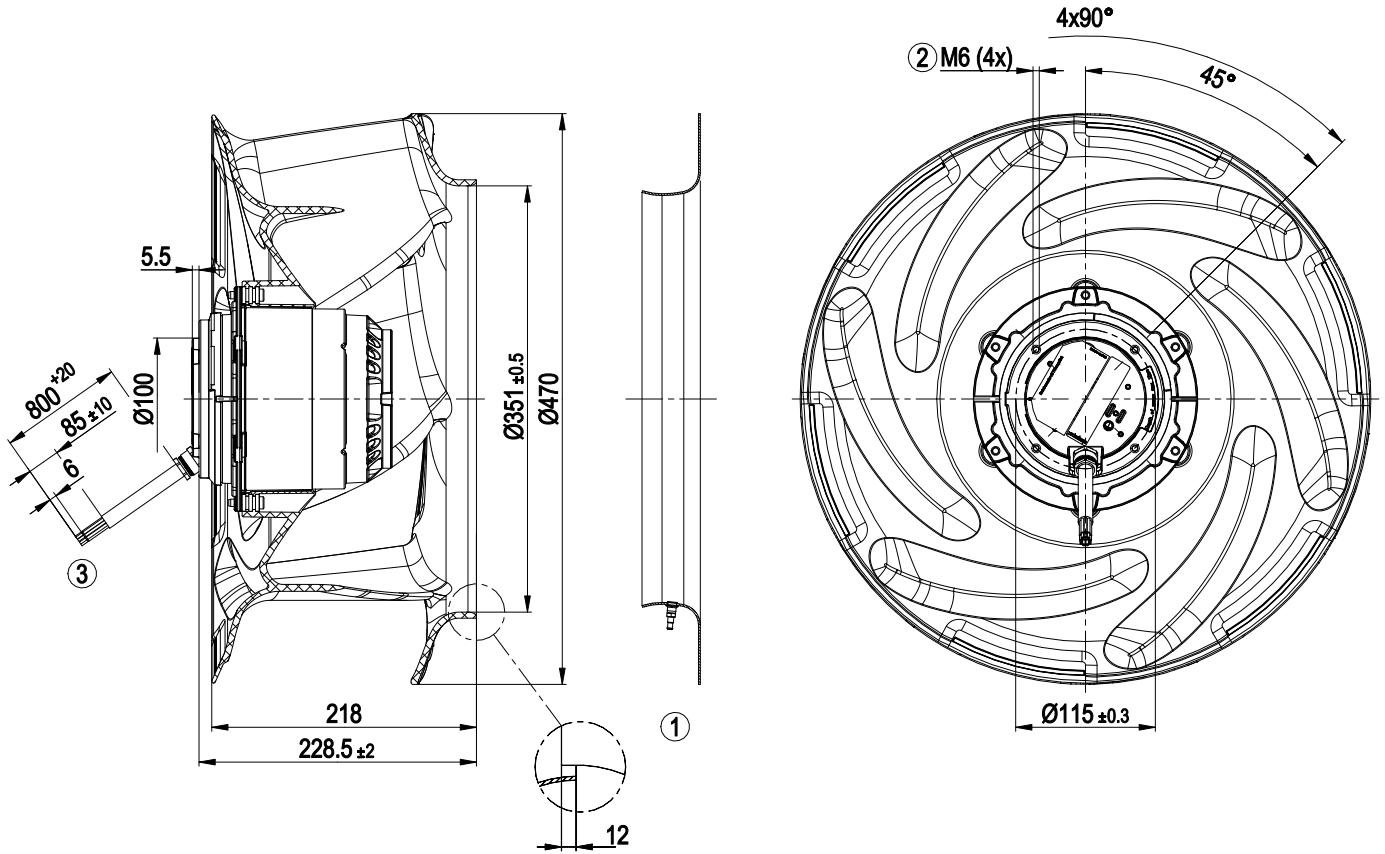

1	Accessory part: Inlet ring 45355-2-4013 with pressure tap (k-factor: 250) (not included in scope of delivery)
2	Max. clearance for screw 12 mm
3	Cable silicone 9G 0.75 mm ²
	9x splice



Accessory part

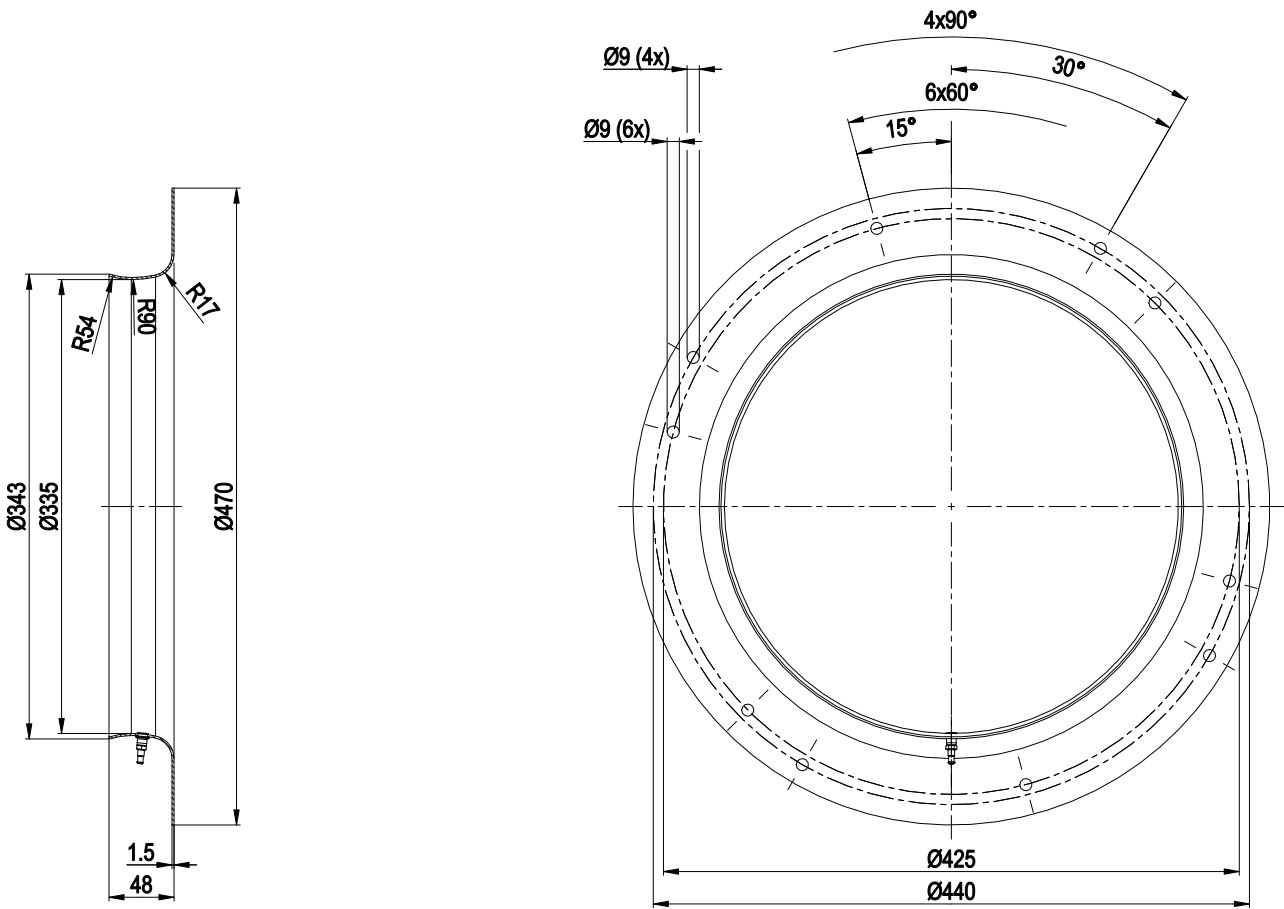

Inlet ring 45355-2-4013 with pressure tap (k-factor: 250)



Connection diagram

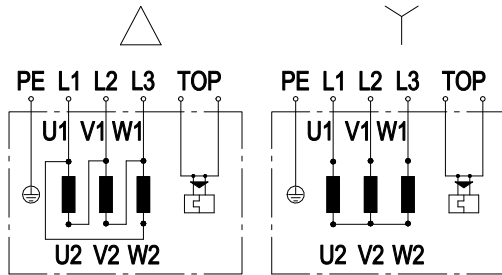

Note: Change of rotation direction by reversing two phases

Δ	Delta connection	Y	Star connection	L1	black
L2	blue	L3	brown	U1	black
V1	blue	W1	brown	U2	green
V2	white	W2	yellow	TOP	2x gray
PE	green/yellow				

Curves: Air performance 50 Hz

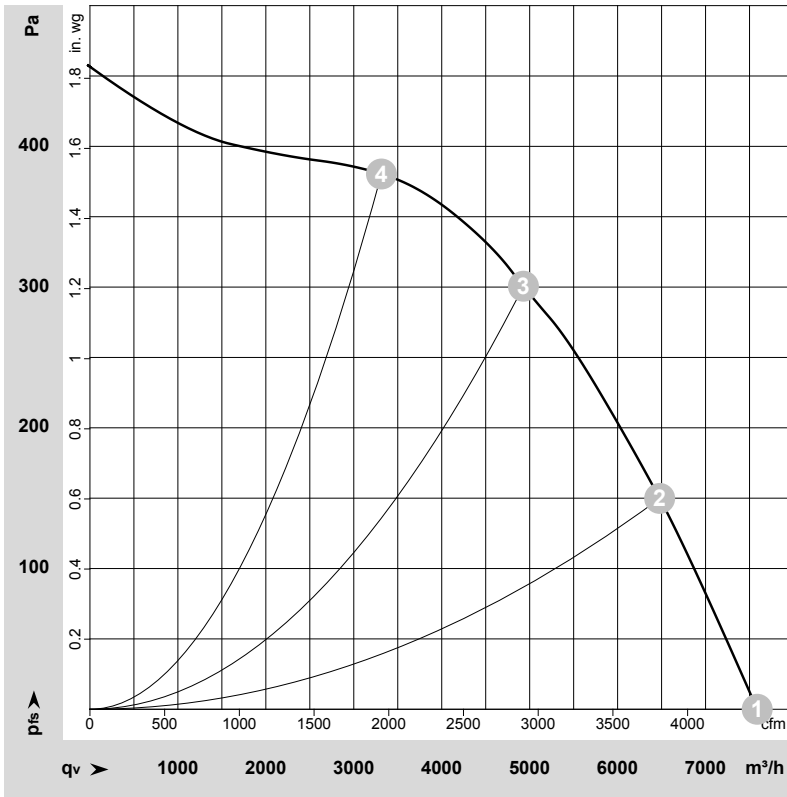

$\rho = 1.15 \text{ kg/m}^3 \pm 2 \%$

Measurement: LU-208311-1

Air performance measured according to ISO 5801 installation category A. For detailed information on the measurement setup, contact ebmpapst. Intake sound level: Sound power level according to ISO 13347 / sound pressure level measured at 1 m distance from fan axis. The values given are valid under the specified measuring conditions and may vary due to conditions of installation. For deviations from the standard configuration, the parameters have to be checked on the installed unit.

Measured values

	Wired	U	f	n	P _e	I	LpA _{in}	LwA _{in}	LwA _{out}	q _v	p _{fs}	q _v	p _{fs}
		V	Hz	min ⁻¹	W	A	dB(A)	dB(A)	dB(A)	m ³ /h	Pa	cfm	in. wg
1	Y	400	50	1445	535	1.84	69	77	80	7585	0	4465	0.00
2	Y	400	50	1430	655	1.90	66	74	78	6480	150	3815	0.60
3	Y	400	50	1420	720	1.90	62	70	75	4930	300	2900	1.20
4	Y	400	50	1425	683	1.90	63	72	76	3315	380	1950	1.53

Wired = Wiring · U = Voltage · f = Frequency · n = Speed (rpm) · P_e = Power consumption · I = Current draw · LpA_{in} = Sound pressure level intake side · LwA_{in} = Sound power level intake side
 LwA_{out} = Sound power level outlet side · q_v = Air flow · p_{fs} = Pressure increase



Curves: Air performance 60 Hz

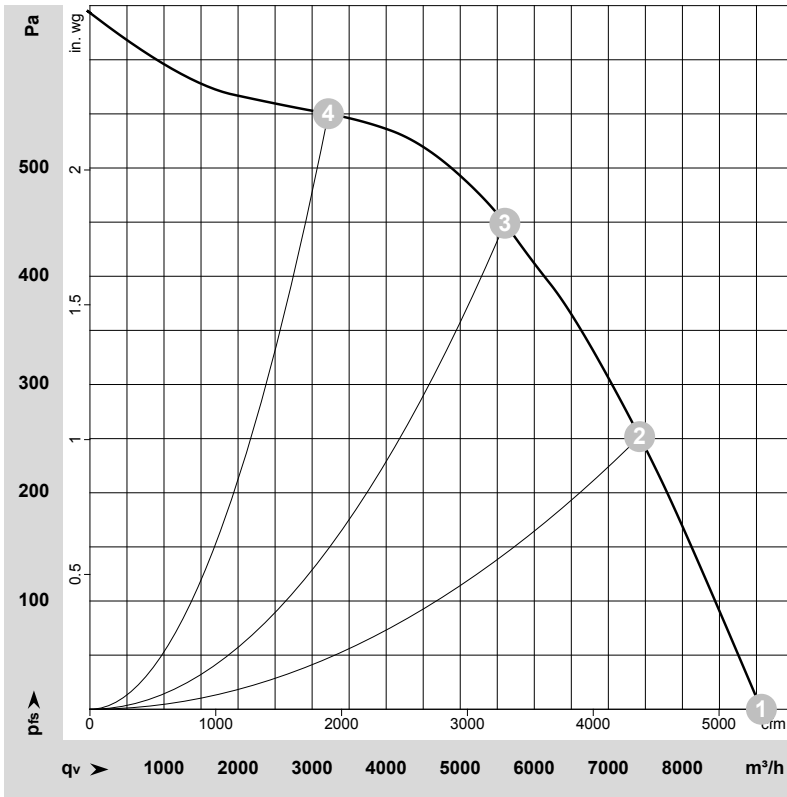

$\rho = 1.15 \text{ kg/m}^3 \pm 2 \%$

Measurement: LU-208354-1

Air performance measured according to ISO 5801 installation category A. For detailed information on the measurement setup, contact ebmpapst. Intake sound level: Sound power level according to ISO 13347 / sound pressure level measured at 1 m distance from fan axis. The values given are valid under the specified measuring conditions and may vary due to conditions of installation. For deviations from the standard configuration, the parameters have to be checked on the installed unit.

Measured values

	Wired	U	f	n	P _e	I	LpA _{in}	LwA _{in}	LwA _{out}	q _v	p _{fs}	q _v	p _{fs}
		V	Hz	min ⁻¹	W	A	dB(A)	dB(A)	dB(A)	m ³ /h	Pa	cfm	in. wg
1	Y	480	60	1720	864	2.00	74	81	84	9065	0	5335	0.00
2	Y	480	60	1690	1115	2.21	69	77	81	7420	250	4370	1.00
3	Y	480	60	1680	1190	2.20	67	75	79	5605	450	3300	1.81
4	Y	480	60	1695	1059	2.14	71	79	82	3220	550	1895	2.21

Wired = Wiring · U = Voltage · f = Frequency · n = Speed (rpm) · P_e = Power consumption · I = Current draw · LpA_{in} = Sound pressure level intake side · LwA_{in} = Sound power level intake side
 LwA_{out} = Sound power level outlet side · q_v = Air flow · p_{fs} = Pressure increase

