

R4D330-AA08-12 ebmpapst Datasheet

sales@fansco.com

www.fansco.com

Limited partnership · Headquarters Mulfingen

Amtsgericht (court of registration) Stuttgart · HRA 590344

General partner Elektrobau Mulfingen GmbH · Headquarters Mulfingen

Amtsgericht (court of registration) Stuttgart · HRB 590142

Nominal data

Type	R4D330-AA08-12		
Motor	M4D074-DF		
Phase		3~	3~
Nominal voltage	VAC	400	400
Wiring		Y	Y
Frequency	Hz	50	60
Method of obtaining data		fa	fa
Valid for approval/standard		CE	CE
Speed (rpm)	min ⁻¹	1450	1680
Power consumption	W	86	112
Current draw	A	0.3	0.26
Min. back pressure	Pa	0	0
Min. back pressure	inH ₂ O	0	0
Min. ambient temperature	°C	-25	-25
Max. ambient temperature	°C	50	40
Starting current	A	1.2	1.1

ml = Max. load · me = Max. efficiency · fa = Free air · cs = Customer specification · ce = Customer equipment
Subject to change



Technical description

Weight	4 kg
Fan size	330 mm
Rotor surface	Painted black
Impeller material	PP plastic
Number of blades	6
Direction of rotation	Clockwise, viewed toward rotor
Degree of protection	IP44; installation- and position-dependent
Insulation class	"B"
Moisture (F) / Environmental (H) protection class	F2-2
Max. permitted ambient temp. for motor (transport/storage)	+ 80 °C
Min. permitted ambient temp. for motor (transport/storage)	- 40 °C
Installation position	Any
Condensation drainage holes	None
Mode	S1
Motor bearing	Ball bearing
Touch current according to IEC 60990 (measuring circuit Fig. 4, TN system)	< 0.75 mA
Motor protection	Thermal overload protector (TOP) with basic insulation
With cable	Variable
Protection class	I (with customer connection of protective earth)
Conformity with standards	EN 60335-1; CE
Approval	CCC; CSA C22.2 No. 100; UL 1004-1

Product drawing

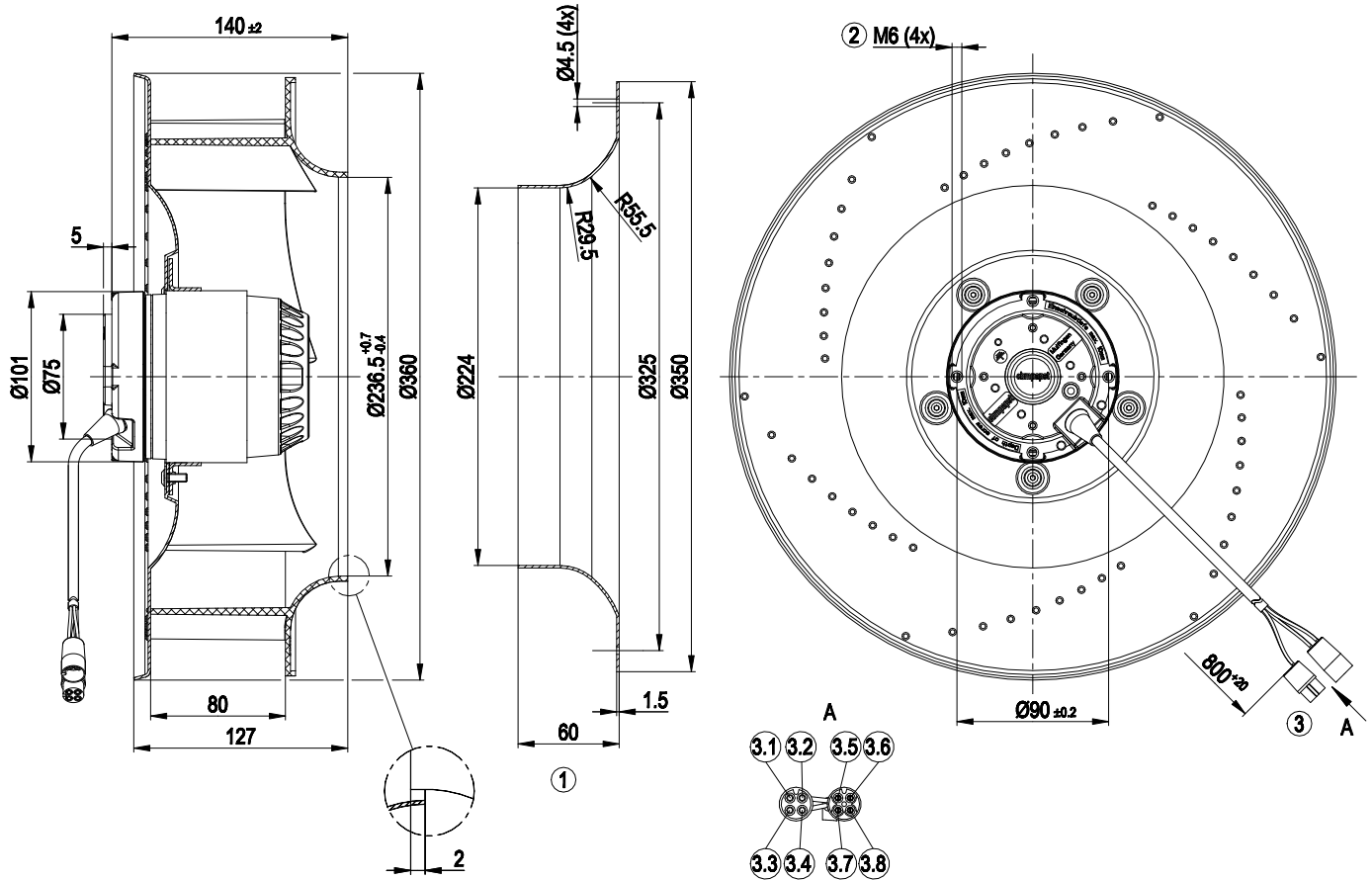

1	Accessory part: inlet ring 51357-2-4013 not included in scope of delivery
2	Max. clearance for screw 10 mm
3	Cable PFA AWG20 (green/yellow AWG18), 4-pole connector housing tyco 925075-7, 4x plug pin tyco 163555-6, 4-pole connector housing tyco 925076-7, 4x plug pin tyco 163303-8
3.1	not used
3.2	TW (gray)
3.3	not used
3.4	TW (gray)
3.5	PE (green/yellow)
3.6	L1 (black)
3.7	L3 (brown)
3.8	L2 (blue)



Connection diagram

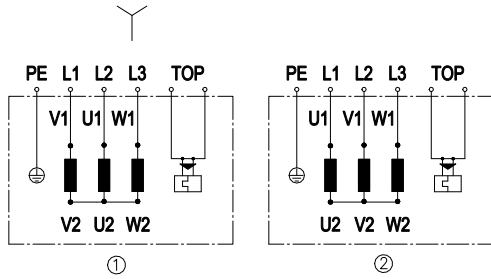

Change of rotation direction by reversing two phases

	Three-phase motor
Y	Star connection
1	Counterclockwise operation
L1	= V1 = blue
L2	= U1 = black
L3	= W1 = brown
2	Clockwise operation
L1	= U1 = black
L2	= V1 = blue
L3	= W1 = brown
PE	green/yellow
TOP	2x gray

Curves: Air performance 50 Hz

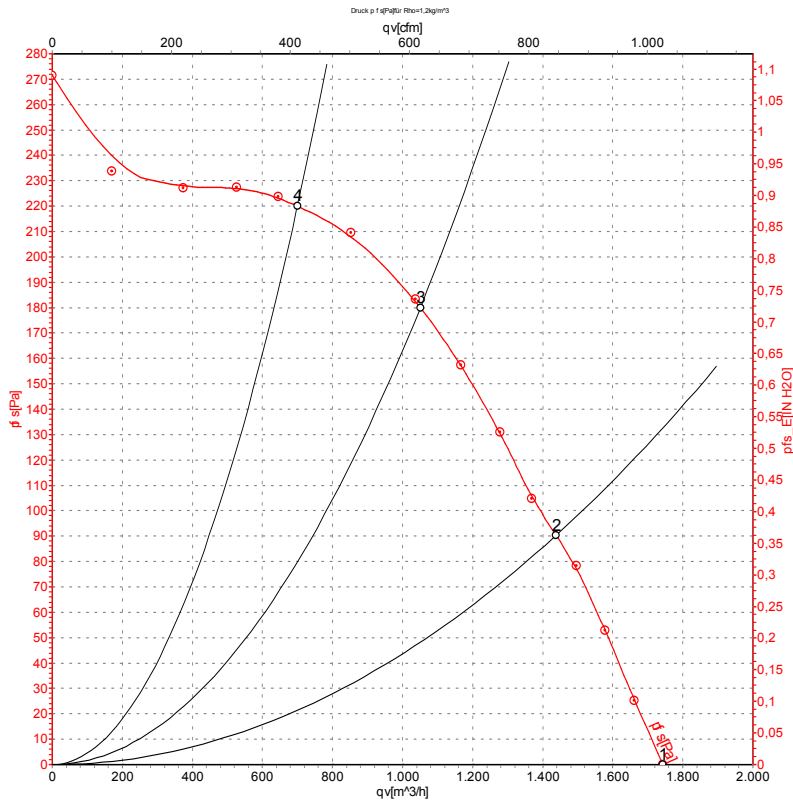

Measurement: LU-32632-1

Air performance measured according to ISO 5801 installation category A. For detailed information on the measurement setup, contact ebm-papst. Intake sound level: Sound power level according to ISO 13347 / sound pressure level measured at 1 m distance from fan axis. The values given are valid under the specified measuring conditions and may vary due to conditions of installation. For deviations from the standard configuration, the parameters have to be checked on the installed unit.

Measured values

	U	f	n	P _e	I	q _v	p _{fs}	q _v	p _{fs}
	V	Hz	min ⁻¹	W	A	m³/h	Pa	cfm	inH2O
1	400	50	1450	86	0.30	1745	0	1025	0.00
2	400	50	1430	107	0.31	1440	90	845	0.36
3	400	50	1410	123	0.32	1050	180	620	0.72
4	400	50	1415	118	0.31	700	220	410	0.88

U = Power supply · f = Frequency · n = Speed (rpm) · P_e = Power consumption · I = Current draw · q_v = Air flow · p_{fs} = Pressure increase



Curves: Air performance 60 Hz

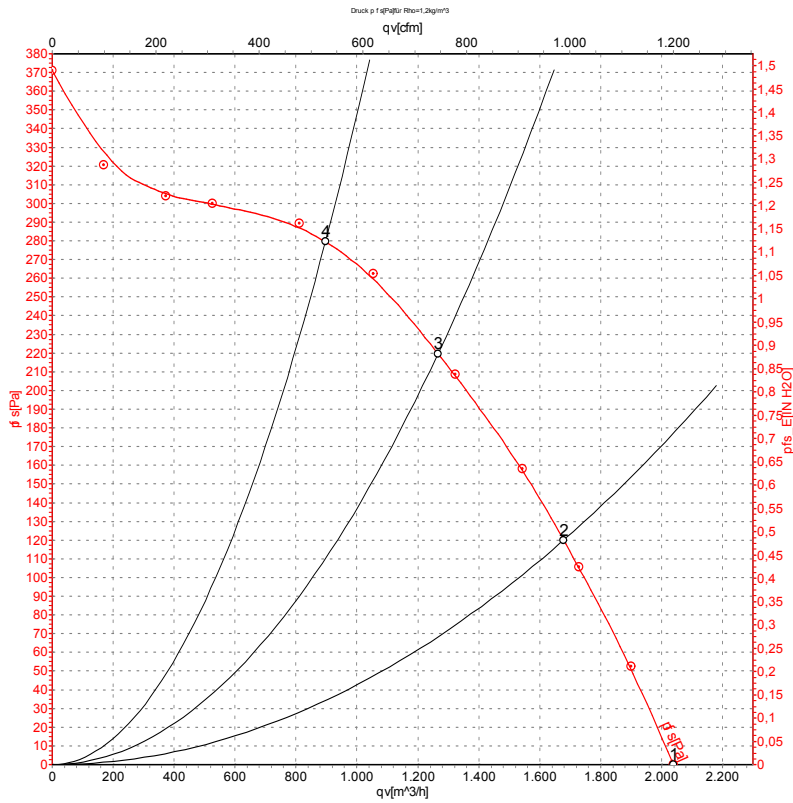

Measurement: LU-32633-1

Air performance measured according to ISO 5801 installation category A. For detailed information on the measurement setup, contact ebm-papst. Intake sound level: Sound power level according to ISO 13347 / sound pressure level measured at 1 m distance from fan axis. The values given are valid under the specified measuring conditions and may vary due to conditions of installation. For deviations from the standard configuration, the parameters have to be checked on the installed unit.

Measured values

	U	f	n	P _e	I	q _v	p _{fs}	q _v	p _{fs}
	V	Hz	min ⁻¹	W	A	m ³ /h	Pa	cfm	inH ₂ O
1	400	60	1680	112	0.26	2040	0	1200	0.00
2	400	60	1645	150	0.30	1680	120	990	0.48
3	400	60	1615	173	0.32	1265	220	745	0.88
4	400	60	1615	170	0.32	895	280	530	1.12

U = Power supply · f = Frequency · n = Speed (rpm) · P_e = Power consumption · I = Current draw · q_v = Air flow · p_{fs} = Pressure increase

