

R4D310-CK03-05 ebmpapst Datasheet

sales@fansco.com

www.fansco.com

Limited partnership · Headquarters Mulfingen

Amtsgericht (court of registration) Stuttgart · HRA 590344

General partner Elektrobau Mulfingen GmbH · Headquarters Mulfingen

Amtsgericht (court of registration) Stuttgart · HRB 590142

Nominal data

Type	R4D310-CK03-05	
Motor	M4D138-HF	
Phase		3~
Nominal voltage	VAC	400
Wiring		Y
Frequency	Hz	50
Method of obtaining data		ml
Valid for approval/standard		CE
Speed (rpm)	min ⁻¹	1310
Power consumption	W	2180
Current draw	A	3.9
Min. back pressure	Pa	0
Min. back pressure	in. wg	0
Min. ambient temperature	°C	-40
Max. ambient temperature	°C	55
Starting current	A	14

ml = Max. load · me = Max. efficiency · fa = Free air · cs = Customer specification · ce = Customer equipment
Subject to change

Data according to Commission Regulation (EU) 327/2011

	Actual	Req. 2015				
01 Overall efficiency η_{es}	%	37.5	37.3	09 Power consumption P_e	kW	0.87
02 Measurement category		A		09 Air flow q_v	m ³ /h	2005
03 Efficiency category		Static		09 Pressure increase p_{fs}	Pa	593
04 Efficiency grade N		44.2	44	10 Speed (rpm) n	min ⁻¹	1435
05 Variable speed drive		No		11 Specific ratio*		1.01

Data obtained at optimum efficiency level.
The ErP data is determined using a motor-impeller combination in a standardized measurement setup.

* Specific ratio = $1 + p_{fs} / 100\,000\text{ Pa}$

LU-111165



Technical description

Weight	19.1 kg
Fan size	310 mm
Rotor surface	Cast in aluminum
Impeller material	Sheet steel, hot-dip galvanized
Direction of rotation	Counterclockwise, viewed toward rotor
Degree of protection	IP54
Insulation class	"F"
Moisture (F) / Environmental (H) protection class	F3-1
Ambient temperature note	Occasional start-up between -40°C and -25°C is permissible. For continuous operation at temperatures below -25°C (e.g. refrigeration applications) we recommend our fan design with special low-temperature bearings.
Max. permitted ambient temp. for motor (transport/storage)	+ 80 °C
Min. permitted ambient temp. for motor (transport/storage)	- 40 °C
Installation position	Any
Condensation drainage holes	On rotor and stator sides
Mode	S1
Motor bearing	Ball bearing
Touch current according to IEC 60990 (measuring circuit Fig. 4, TN system)	<= 3.5 mA
Motor protection	Thermal overload protector (TOP) with basic insulation
With cable	Lateral
Protection class	I (with customer connection of protective earth)
Conformity with standards	EN 60034-1 (2010); EN 61800-5-1; CE
Approval	VDE; EAC

Product drawing

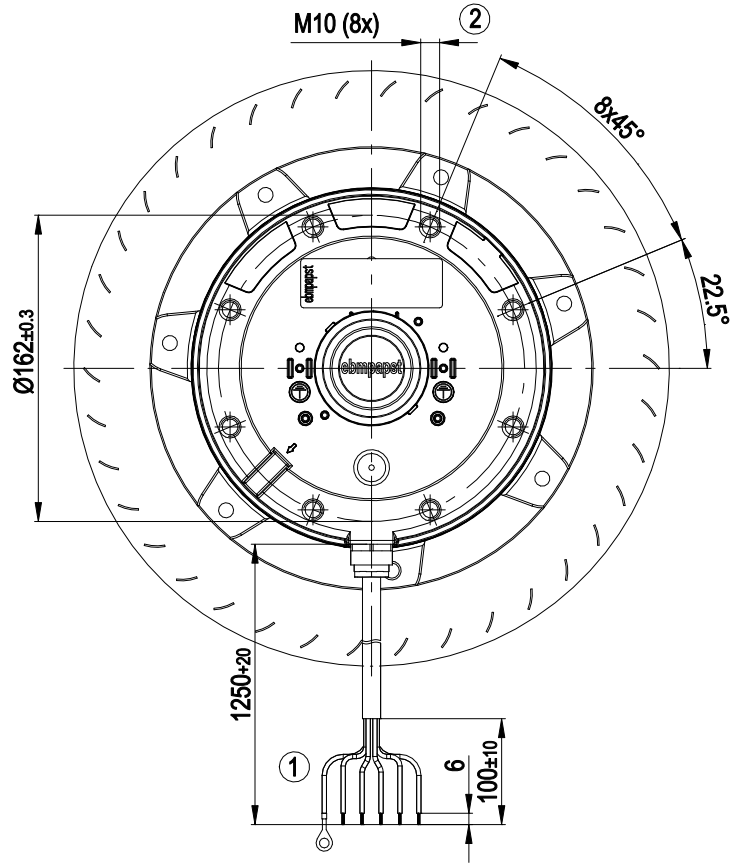
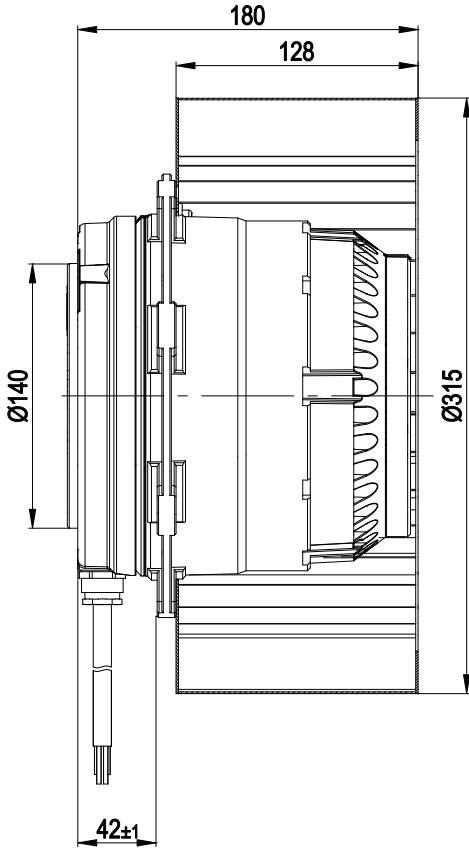

- 1 Cable halogen-free, 5x crimped splices and 1x crimped ring terminal
- 2 Max. clearance for screw 18 mm



Connection diagram

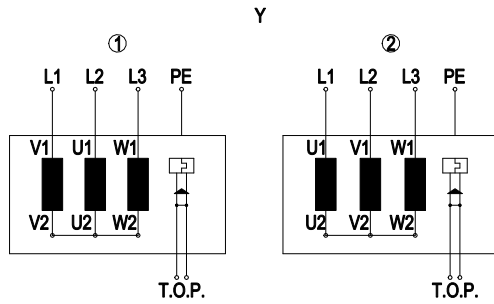

Y	Star connection, three-phase motor
1	Counterclockwise operation
L1	blue
L2	black
L3	brown
PE	green/yellow
TOP	gray
2	Clockwise operation
L1	black
L2	blue
L3	brown
PE	green/yellow
TOP	gray



Curves: Air performance 50 Hz Y

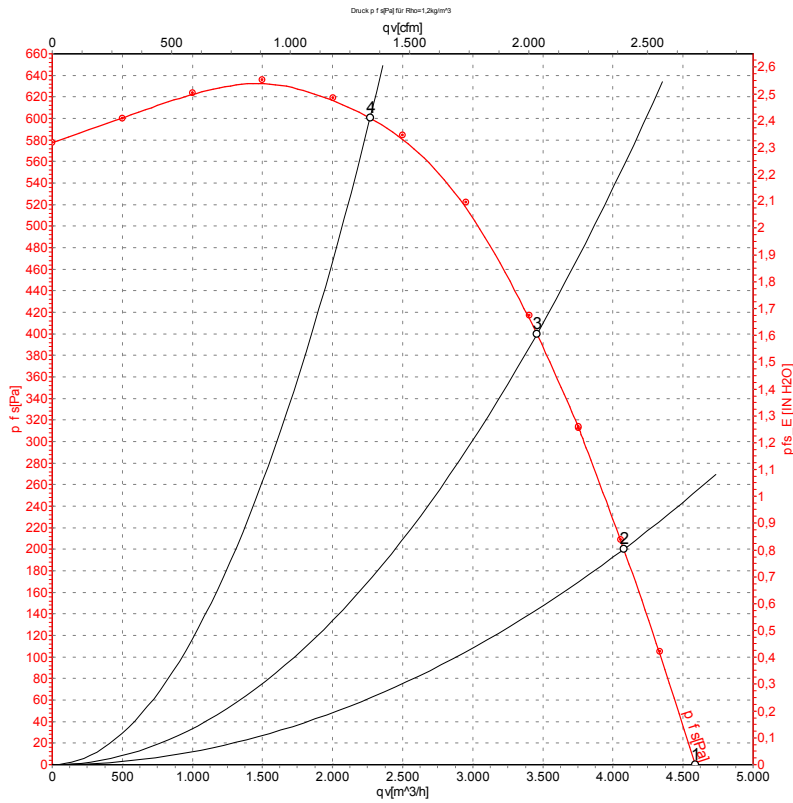

Measurement: LU-111165-1

Air performance measured according to ISO 5801 installation category A. For detailed information on the measurement setup, contact ebm-papst. Intake sound level: Sound power level according to ISO 13347 / sound pressure level measured at 1 m distance from fan axis. The values given are valid under the specified measuring conditions and may vary due to conditions of installation. For deviations from the standard configuration, the parameters have to be checked on the installed unit.

Measured values

	Wired	U	f	n	P _e	I	LpA _{in}	LwA _{in}	q _v	p _{fs}	q _v	p _{fs}
		V	Hz	min ⁻¹	W	A	dB(A)	dB(A)	m ³ /h	Pa	cfm	in. wg
1	Y	400	50	1310	2180	3.90	86	91	4585	0	2700	0.00
2	Y	400	50	1340	1857	3.41	84	89	4075	200	2400	0.80
3	Y	400	50	1375	1504	2.92	81	87	3455	400	2035	1.61
4	Y	400	50	1425	978	2.27	76	82	2270	600	1335	2.41

Wired = Wiring · U = Power supply · f = Frequency · n = Speed (rpm) · P_e = Power consumption · I = Current draw · LpA_{in} = Sound pressure level intake side · LwA_{in} = Sound power level intake side
 q_v = Air flow · p_{fs} = Pressure increase

