

R4D200-AL12-05 ebmpapst Datasheet

sales@fansco.com

www.fansco.com

Limited partnership · Headquarters Mulfingen

Amtsgericht (court of registration) Stuttgart · HRA 590344

General partner Elektrobau Mulfingen GmbH · Headquarters Mulfingen

Amtsgericht (court of registration) Stuttgart · HRB 590142

Nominal data

Type	R4D200-AL12-05				
Motor	M4D074-EI				
Phase		1~	1~	1~	1~
Nominal voltage	VAC	230	230	400	400
Wiring		Δ	Δ	Y	Y
Frequency	Hz	50	60	50	60
Method of obtaining data		fa	ml	fa	ml
Valid for approval/standard		-	-	-	-
Speed (rpm)	min ⁻¹	1350	1530	1350	1530
Power consumption	W	285	360	285	360
Current draw	A	1.0	1.13	0.58	0.65
Min. back pressure	Pa	0	200	0	200
Min. back pressure	inH ₂ O	0	0.8	0	0.8
Min. ambient temperature	°C	-25	-25	-25	-25
Max. ambient temperature	°C	45	45	45	45

ml = Max. load · me = Max. efficiency · fa = Free air · cs = Customer specification · ce = Customer equipment

Subject to change



Technical description

Weight	4 kg
Fan size	200 mm
Rotor surface	Painted black
Impeller material	Sheet steel, galvanized
Direction of rotation	Clockwise, viewed toward rotor
Degree of protection	IP44
Insulation class	"B"
Moisture (F) / Environmental (H) protection class	H0+
Max. permitted ambient temp. for motor (transport/storage)	+ 80 °C
Min. permitted ambient temp. for motor (transport/storage)	- 40 °C
Installation position	Any
Condensation drainage holes	On rotor side
Mode	S1
Motor bearing	Ball bearing
Touch current according to IEC 60990 (measuring circuit Fig. 4, TN system)	< 0.75 mA
With cable	Axial
Protection class	I (with customer connection of protective earth)
Conformity with standards	EN 60335-1, motor does not have factory-installed overheating protection
Approval	EAC

Product drawing

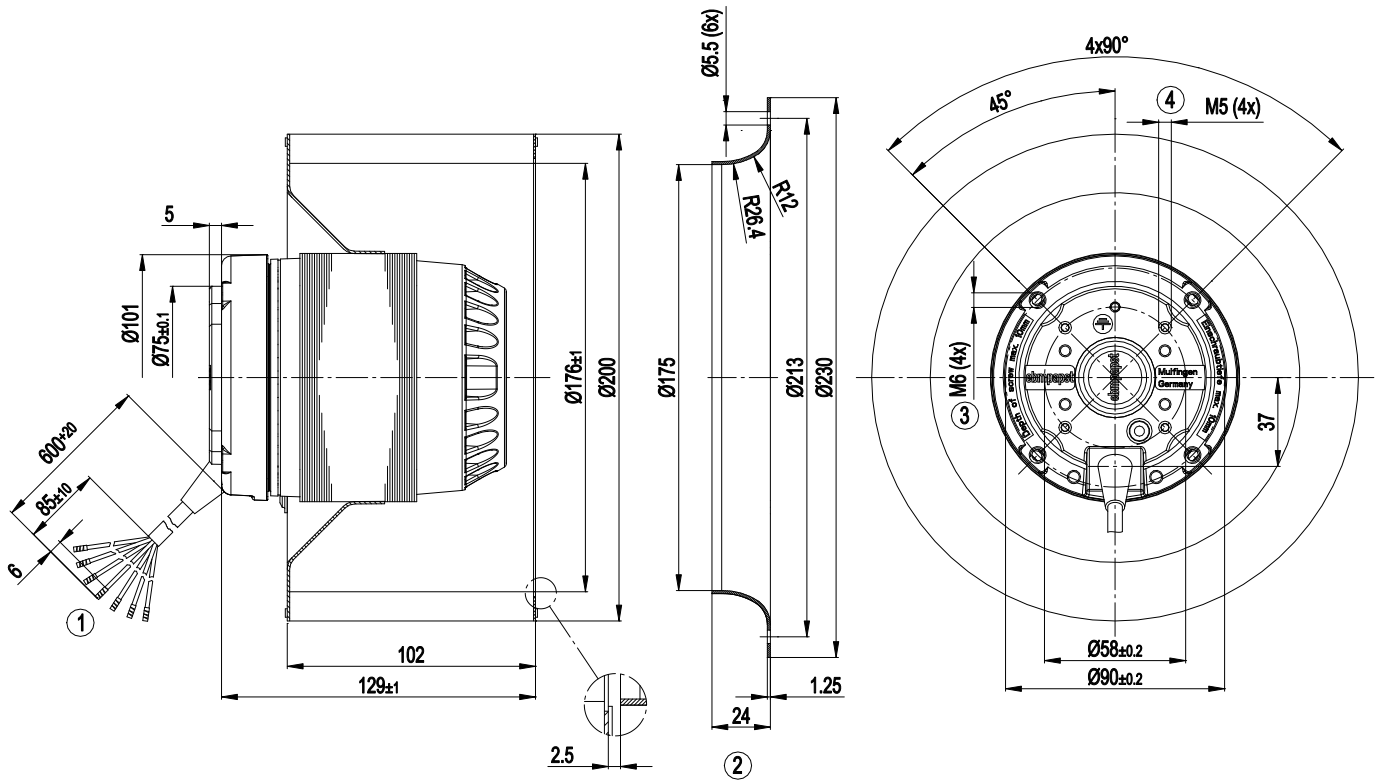

1	Cable A03VV-F7G0.5, 7x crimped splices
2	Accessory part: inlet ring 09605-2-4013 not included in scope of delivery
3	Max. clearance for screw 10 mm
4	Max. clearance for screw 6 mm



Connection diagram

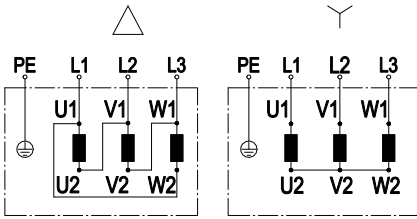

Change of rotation direction by reversing two phases

	Three-phase motor	Δ	Delta connection	Y	Star connection
L1	= U1 = black	L2	= V1 = blue	L3	= W1 = brown
U2	green	V2	white	W2	yellow
PE	green/yellow				

Curves: Air performance 50 Hz

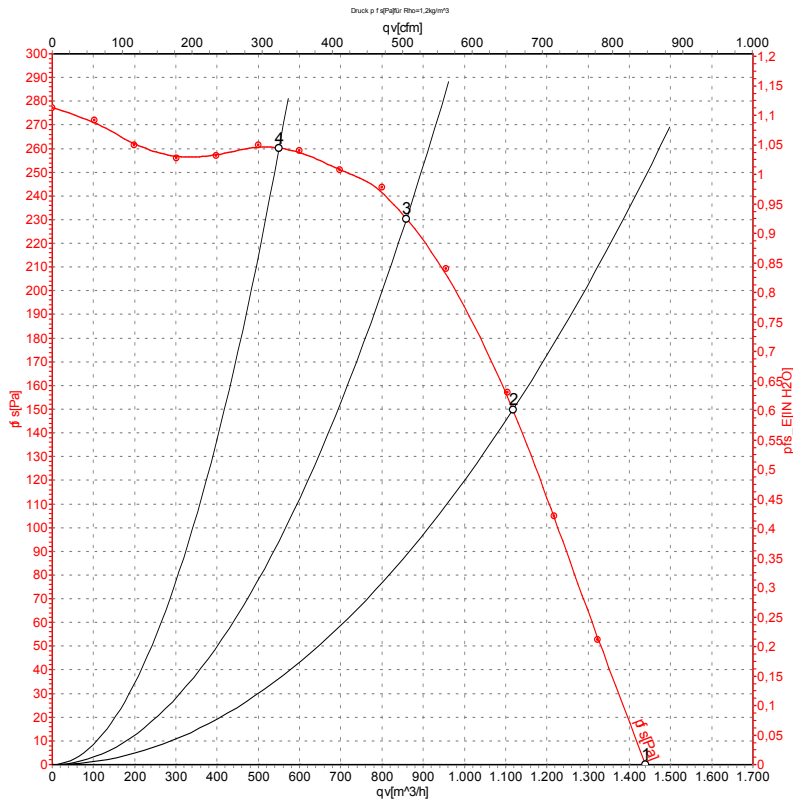

Measurement: LU-105240-1

Air performance measured according to ISO 5801 installation category A. For detailed information on the measurement setup, contact ebmpapst. Intake sound level: Sound power level according to ISO 13347 / sound pressure level measured at 1 m distance from fan axis. The values given are valid under the specified measuring conditions and may vary due to conditions of installation. For deviations from the standard configuration, the parameters have to be checked on the installed unit.

Measured values

	Wired	U	f	n	P _e	I	qv	p _{fs}	qv	p _{fs}
		V	Hz	min ⁻¹	W	A	m ³ /h	Pa	CFM	inH2O
1	Y	400	50	1350	285	0.58	1440	0	850	0.00
2	Y	400	50	1385	232	0.51	1120	150	660	0.60
3	Y	400	50	1420	186	0.48	860	230	505	0.92
4	Y	400	50	1445	140	0.46	550	260	325	1.04

Wired = Wiring · U = Power supply · f = Frequency · n = Speed (rpm) · P_e = Power consumption · I = Current draw · qv = Air flow · p_{fs} = Pressure increase



Curves: Air performance 60 Hz

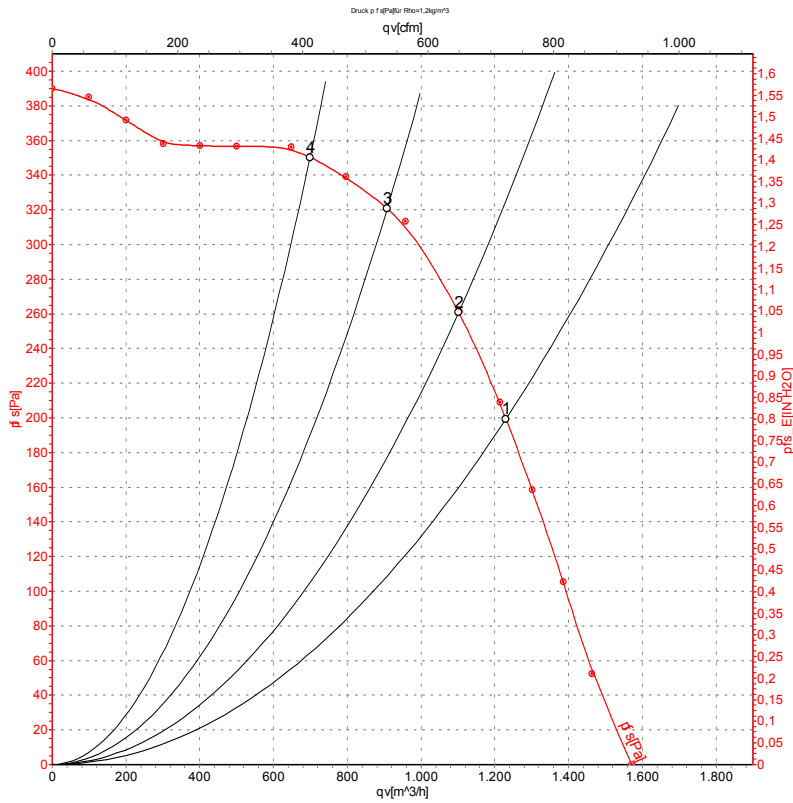

Measurement: LU-105243-1

Air performance measured according to ISO 5801 installation category A. For detailed information on the measurement setup, contact ebm-papst. Intake sound level: Sound power level according to ISO 13347 / sound pressure level measured at 1 m distance from fan axis. The values given are valid under the specified measuring conditions and may vary due to conditions of installation. For deviations from the standard configuration, the parameters have to be checked on the installed unit.

Measured values

	Wired	U	f	n	P _e	I	qv	p _{fs}	qv	p _{fs}
		V	Hz	min ⁻¹	W	A	m ³ /h	Pa	CFM	inH ₂ O
1	Y	400	60	1530	360	0.65	1230	200	725	0.80
2	Y	400	60	1585	293	0.52	1100	260	650	1.04
3	Y	400	60	1635	242	0.45	910	320	535	1.28
4	Y	400	60	1675	194	0.40	700	350	410	1.41

Wired = Wiring · U = Power supply · f = Frequency · n = Speed (rpm) · P_e = Power consumption · I = Current draw · qv = Air flow · p_{fs} = Pressure increase

