

**ebm-papst Ventilator (Shanghai) Co.,Ltd.**

No.418, Hua Jing Road, Wai Gao Qiao Free Trade Zone, Pudong

R3G630-RB32-71/F01 ebmpapst Datasheet

sales@fansco.com

www.fansco.com

**Nominal data**

<b>Type</b>	<b>R3G630-RB32-71/F01</b>	
<b>Motor</b>	<b>M3G150-IF</b>	
Phase		3~
Nominal voltage	VAC	400
Nominal voltage range	VAC	380 .. 480
Frequency	Hz	50/60
Method of obtaining data		ml
Speed (rpm)	min <sup>-1</sup>	1300
Power consumption	W	2800
Current draw	A	4.2
Min. ambient temperature	°C	-25
Max. ambient temperature	°C	55

ml = Max. load · me = Max. efficiency · fa = Free air · cs = Customer specification · ce = Customer equipment  
Subject to change

**Data according to ErP Directive**

		Actual	Req. 2015			
01 Overall efficiency $\eta_{es}$	%	65	56	09 Power consumption $P_{ed}$	kW	2.67
02 Measurement category		A		09 Air flow $q_v$	m <sup>3</sup> /h	11140
03 Efficiency category		Static		09 Pressure increase $p_{fs}$	Pa	531
04 Efficiency grade N		71	62	10 Speed (rpm) n	min <sup>-1</sup>	1300
05 Variable speed drive		Yes		11 Specific ratio*		1.01

Data obtained at optimum efficiency level.

The ErP data is determined using a motor-impeller combination in a standardized measurement setup.

\* Specific ratio =  $1 + p_{fs} / 100\,000\text{ Pa}$ 

LU-146905



## Technical description

<b>Weight</b>	30.5 kg
<b>Fan size</b>	630 mm
<b>Rotor surface</b>	Painted black
<b>Electronics housing material</b>	Die-cast aluminum
<b>Impeller material</b>	PP plastic
<b>Number of blades</b>	6
<b>Direction of rotation</b>	Clockwise, viewed toward rotor
<b>Degree of protection</b>	IP55
<b>Insulation class</b>	"F"
<b>Moisture (F) / Environmental (H) protection class</b>	F4-1
<b>Max. permitted ambient temp. for motor (transport/storage)</b>	+80 °C
<b>Min. permitted ambient temp. for motor (transport/storage)</b>	-40 °C
<b>Installation position</b>	Shaft horizontal or rotor on bottom; rotor on top on request
<b>Condensation drainage holes</b>	On rotor side
<b>Mode</b>	S1
<b>Motor bearing</b>	Ball bearing
<b>Technical features</b>	<ul style="list-style-type: none"> <li>- Output 10 VDC, max. 10 mA</li> <li>- Operation and alarm display</li> <li>- External 24 V input (parameter setting)</li> <li>- External release input</li> <li>- Alarm relay</li> <li>- Integrated PID controller</li> <li>- Motor current limitation</li> <li>- PFC, passive</li> <li>- RS-485 MODBUS-RTU</li> <li>- Soft start</li> <li>- Control input 0-10 VDC / PWM</li> <li>- Control interface with SELV potential safely disconnected from supply</li> <li>- Thermal overload protection for electronics/motor</li> <li>- Line undervoltage / phase failure detection</li> </ul>
<b>EMC immunity to interference</b>	According to EN 61000-6-2 (industrial environment)
<b>EMC interference emission</b>	According to EN 61000-6-3 (household environment), except EN 61000-3-2 for professionally used equipment with a total rated power greater than 1 kW
<b>Touch current according to IEC 60990 (measuring circuit Fig. 4, TN system)</b>	<= 3.5 mA
<b>Electrical hookup</b>	Via terminal box
<b>Motor protection</b>	Reverse polarity and locked-rotor protection
<b>Protection class</b>	I (with customer connection of protective earth)
<b>Conformity with standards</b>	EN 61800-5-1; CE
<b>Approval</b>	EAC

Product drawing

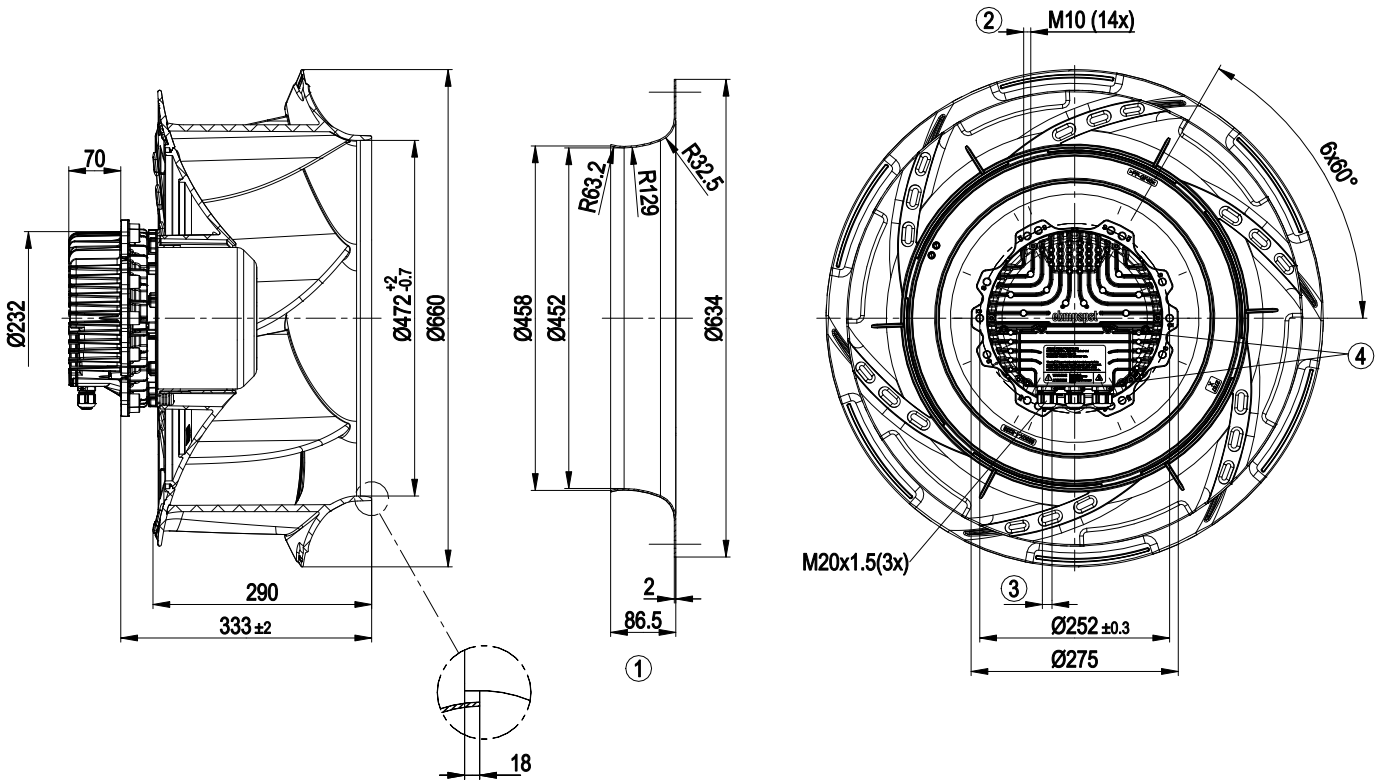

1	Accessory part: inlet ring 63300-2-4013 included in scope of delivery
2	Max. clearance for screw 25 mm
3	Cable diameter min. 4 mm, max. 10 mm, tightening torque $4 \pm 0.6$ Nm
4	Tightening torque $3.5 \pm 0.5$ Nm



# EC centrifugal fan - RadiCal

backward-curved, single-intake

## Connection diagram

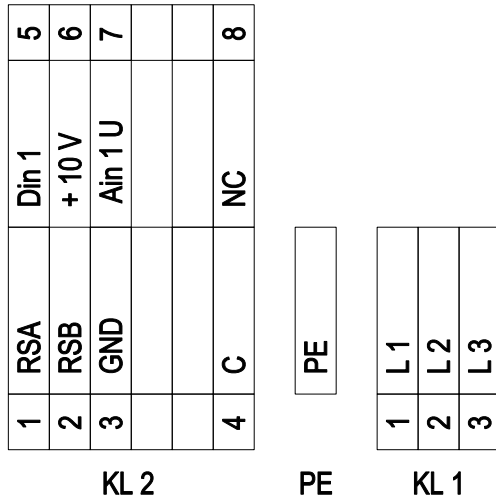

No.	Conn.	Designation	Function/assignment
KL 1	1	L1	Supply connection, power supply 3-phase 380-480 VAC, 50/60 Hz
KL 1	2	L2	Supply connection, power supply 3-phase 380-480 VAC, 50/60 Hz
KL 1	3	L3	Supply connection, power supply 3-phase 380-480 VAC, 50/60 Hz
PE		PE	Ground connection, PE connection
KL 2	1	RSA	Bus connection RS485, RSA, MODBUS-RTU; SELV
KL 2	2	RSB	Bus connection RS485, RSB, MODBUS-RTU; SELV
KL 2	3	GND	Reference ground for control interface; SELV
KL 2	4	C	Status relay, floating status contact, common connection, changeover contact; contact rating 250 VAC / 2 A (AC1)
KL 2	5	Din1	Digital input 1 enable electronics, enable: pin open or applied voltage 5-50 VDC disable: bridge to GND or applied voltage < 1 VDC reset function: triggers software reset after a level change to < 1 V; SELV
KL 2	6	+ 10 V	Fixed voltage output 10 VDC, +10 V ±3%, max. 10 mA, short-circuit-proof, power supply for external devices (e.g. pot); SELV Or: +24 VDC input for parameter setting via MODBUS without line voltage
KL 2	7	Ain1 U	Analog input 1 (set value) 0-10 V, Ri = 100 kΩ, adjustable curve; SELV
KL 2	8	NC	Status relay, floating status contact, break for failure



## Curves: Air performance 50 Hz

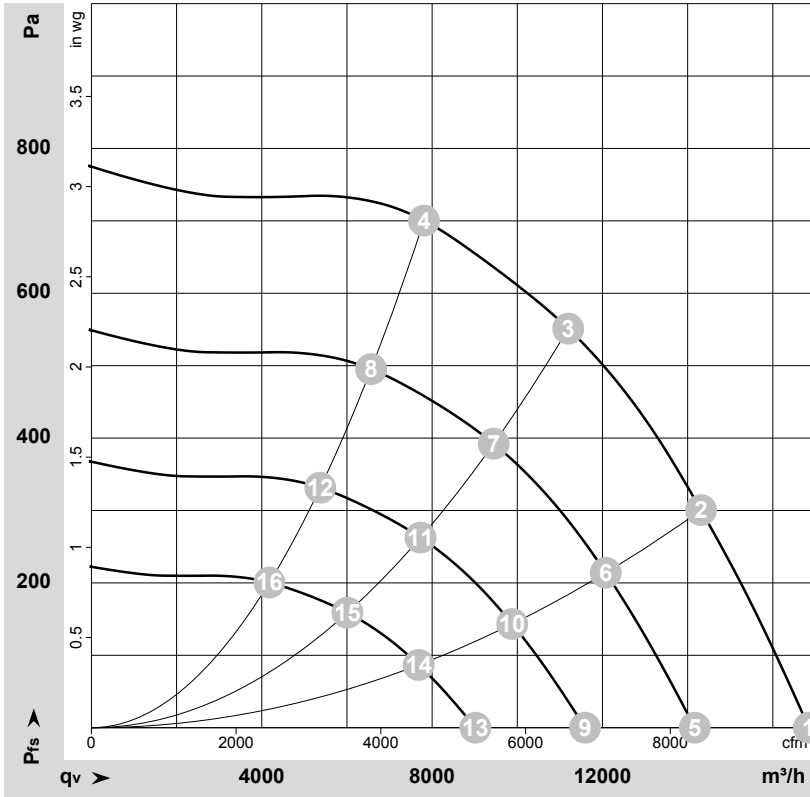

$\rho = 1.15 \text{ kg/m}^3 \pm 2 \%$

Measurement: LU-164207-1

Air performance measured according to ISO 5801 installation category A. For detailed information on the measurement setup, contact ebmpapst. Intake sound level: Sound power level according to ISO 13347 / sound pressure level measured at 1 m distance from fan axis. The values given are valid under the specified measuring conditions and may vary due to conditions of installation. For deviations from the standard configuration, the parameters have to be checked on the installed unit.

## Measured values

	Wired	U	f	n	P <sub>ed</sub>	I	LpA <sub>in</sub>	LwA <sub>in</sub>	LwA <sub>out</sub>	qv	p <sub>fs</sub>	qv	p <sub>fs</sub>
		V	Hz	min <sup>-1</sup>	W	A	dB(A)	dB(A)	dB(A)	m <sup>3</sup> /h	Pa	CFM	inH <sub>2</sub> O
1	Y	400	50	1300	1820	2.86	80	88	92	16845	0	9915	0.00
2	Y	400	50	1300	2455	3.79	74	81	87	14315	300	8425	1.20
3	Y	400	50	1300	2800	4.20	70	78	83	11195	550	6590	2.21
4	Y	400	50	1300	2711	4.17	72	79	84	7810	700	4595	2.81
5	Y	400	50	1100	1082	1.70	76	83	88	14170	0	8340	0.00
6	Y	400	50	1100	1478	2.28	70	77	82	12075	216	7110	0.87
7	Y	400	50	1100	1679	2.58	65	73	79	9445	395	5560	1.59
8	Y	400	50	1100	1611	2.48	68	75	80	6565	498	3865	2.00
9	Y	400	50	900	593	0.93	71	78	83	11590	0	6825	0.00
10	Y	400	50	900	809	1.25	65	72	77	9880	145	5815	0.58
11	Y	400	50	900	920	1.41	60	68	74	7730	264	4550	1.06
12	Y	400	50	900	882	1.36	62	70	75	5375	333	3160	1.34
13	Y	400	50	700	279	0.44	64	72	76	9015	0	5305	0.00
14	Y	400	50	700	381	0.59	58	66	71	7685	88	4525	0.35
15	Y	400	50	700	433	0.66	54	62	67	6010	160	3540	0.64
16	Y	400	50	700	415	0.64	56	63	69	4180	201	2460	0.81

Wired = Wiring · U = Power supply · f = Frequency · n = Speed (rpm) · P<sub>ed</sub> = Power consumption · I = Current draw · LpA<sub>in</sub> = Sound pressure level intake side · LwA<sub>in</sub> = Sound power level intake side  
 LwA<sub>out</sub> = Sound power level outlet side · qv = Air flow · p<sub>fs</sub> = Pressure increase

