

R3G630-RA38-26 ebmpapst Datasheet

sales@fansco.com

www.fansco.com

Limited partnership · Headquarters Mulfingen

Amtsgericht (court of registration) Stuttgart · HRA 590344

General partner Elektrobau Mulfingen GmbH · Headquarters Mulfingen

Amtsgericht (court of registration) Stuttgart · HRB 590142

Nominal data

Type	R3G630-RA38-26	
Motor	M3G150-FF	
Phase		1~
Nominal voltage	VAC	230
Nominal voltage range	VAC	200 .. 277
Frequency	Hz	50/60
Method of obtaining data		ml
Speed (rpm)	min ⁻¹	1030
Power consumption	W	1425
Current draw	A	6.2
Min. ambient temperature	°C	-25
Max. ambient temperature	°C	50

ml = Max. load · me = Max. efficiency · fa = Free air · cs = Customer specification · ce = Customer equipment
Subject to change

Data according to Commission Regulation (EU) 327/2011 (EN 17166)

		Actual	Req. 2015			
01 Overall efficiency η_{es}	%	63.8	52.9	09 Power consumption P_{ed}	kW	1.35
02 Measurement category		A		09 Air flow q_v	m ³ /h	9025
03 Efficiency category		Static		09 Pressure increase p_{fs}	Pa	318
04 Efficiency grade N		72.9	62	10 Speed (rpm) n	min ⁻¹	1030
05 Variable speed drive		Yes		11 Specific ratio [*]		1.00

Data obtained at optimum efficiency level.

The ErP data is determined using a motor-impeller combination in a standardized measurement setup.

^{*} Specific ratio = $1 + p_{fs} / 100\,000\text{ Pa}$

LU-141766



Technical description

Size	630 mm
Motor size	150
Rotor surface	Painted black
Electronics housing material	Die-cast aluminum
Impeller material	PP plastic
Number of blades	6
Direction of rotation	Clockwise, viewed toward rotor
Degree of protection	IP55
Insulation class	"F"
Moisture (F) / Environmental (H) protection class	H1
Max. permitted ambient temp. for motor (transport/storage)	+80 °C
Min. permitted ambient temp. for motor (transport/storage)	-40 °C
Installation position	Shaft horizontal or rotor on bottom; rotor on top on request
Condensation drainage holes	On rotor side
Mode	S1
Motor bearing	Ball bearing
Technical features	<ul style="list-style-type: none"> - Output 10 VDC, max. 10 mA - Output 20 VDC, max. 50 mA - Output for slave 0-10 V - Tach output - Input for sensor 0-10 V or 4-20 mA - External 24 V input (parameter setting) - External release input - Alarm relay - Integrated PID controller - Power limiter - Motor current limitation - PFC, active - RS-485 MODBUS-RTU - Soft start - Control input 0-10 VDC / PWM - Control interface with SELV potential safely disconnected from the mains - Thermal overload protection for electronics/motor - Line undervoltage / phase failure detection
Touch current according to IEC 60990 (measuring circuit Fig. 4, TN system)	<= 3.5 mA
Motor protection	Reverse polarity and locked-rotor protection
With cable	Lateral
Protection class	I (with customer connection of protective earth)
Conformity with standards	EN 61800-5-1; CE
Approval	CSA C22.2 No. 77 + CAN/CSA-E60730-1; EAC; UL 1004-7 + 60730-1

Product drawing

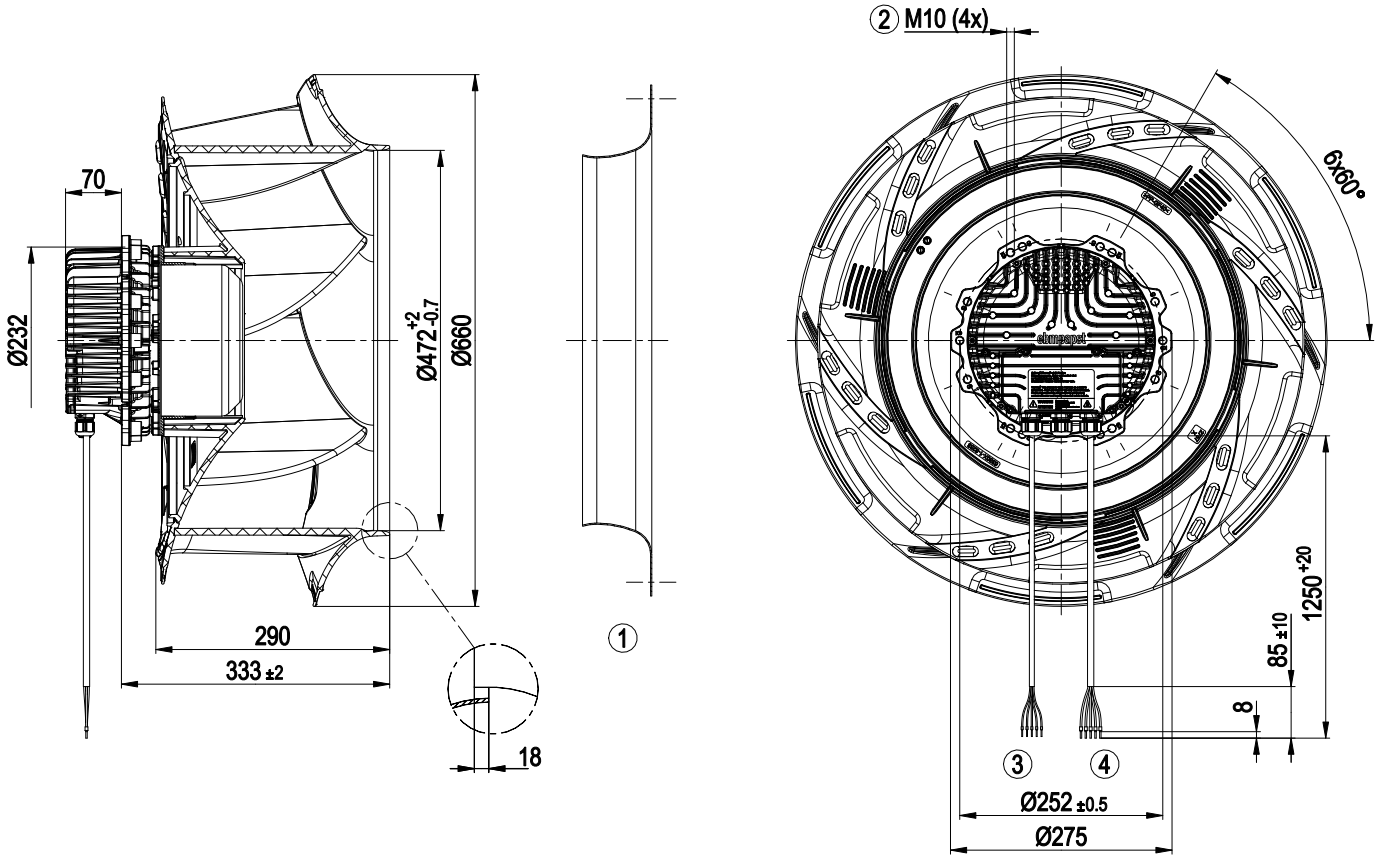

1	Accessory part: inlet ring 63300-2-4013 not included in scope of delivery
2	Max. clearance for screw 25 mm
3	Cable PVC AWG22 5x wire-end ferrule
4	Cable PVC AWG18 5x wire-end ferrule



Accessory part

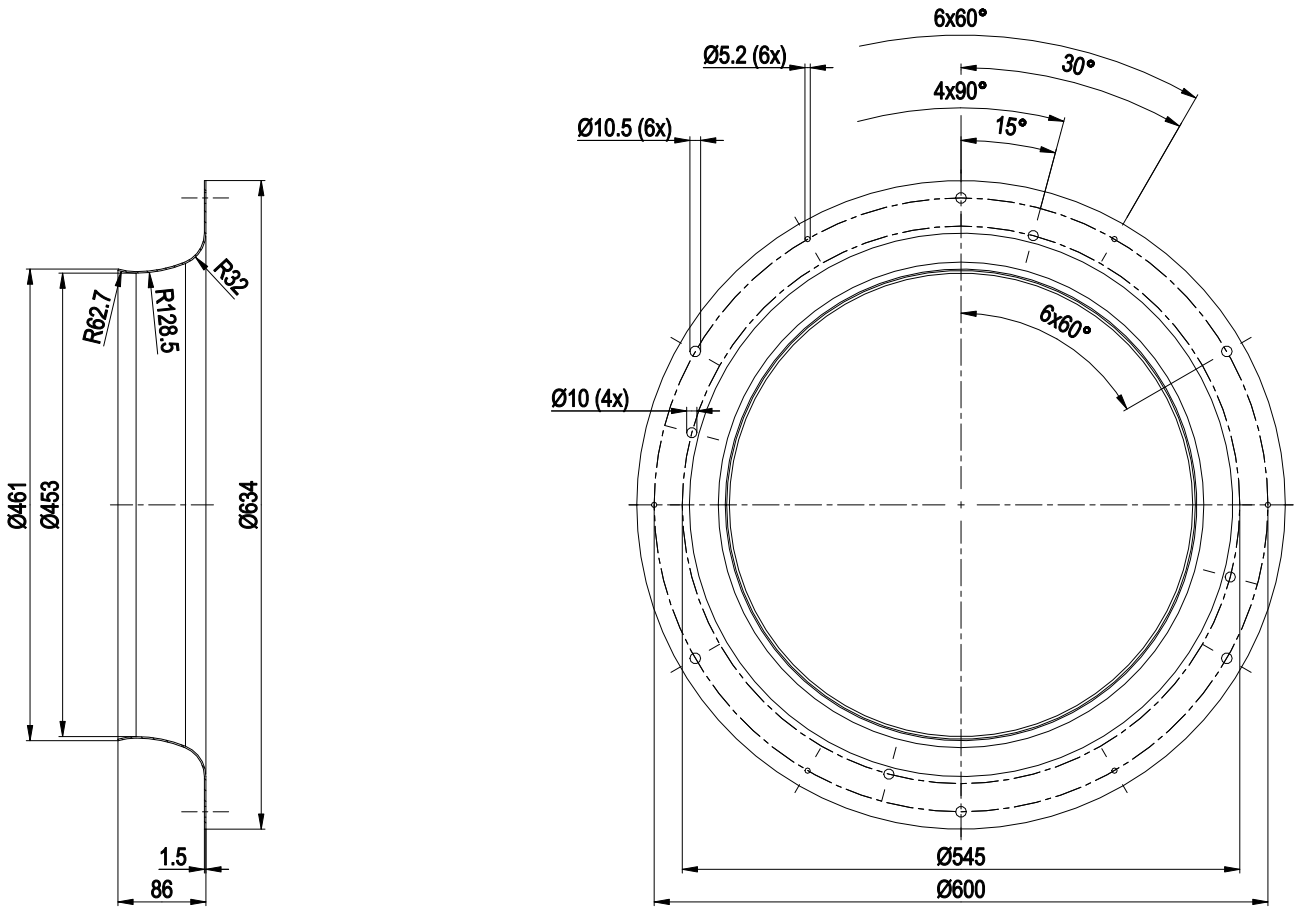

Inlet ring 63300-2-4013



Connection diagram

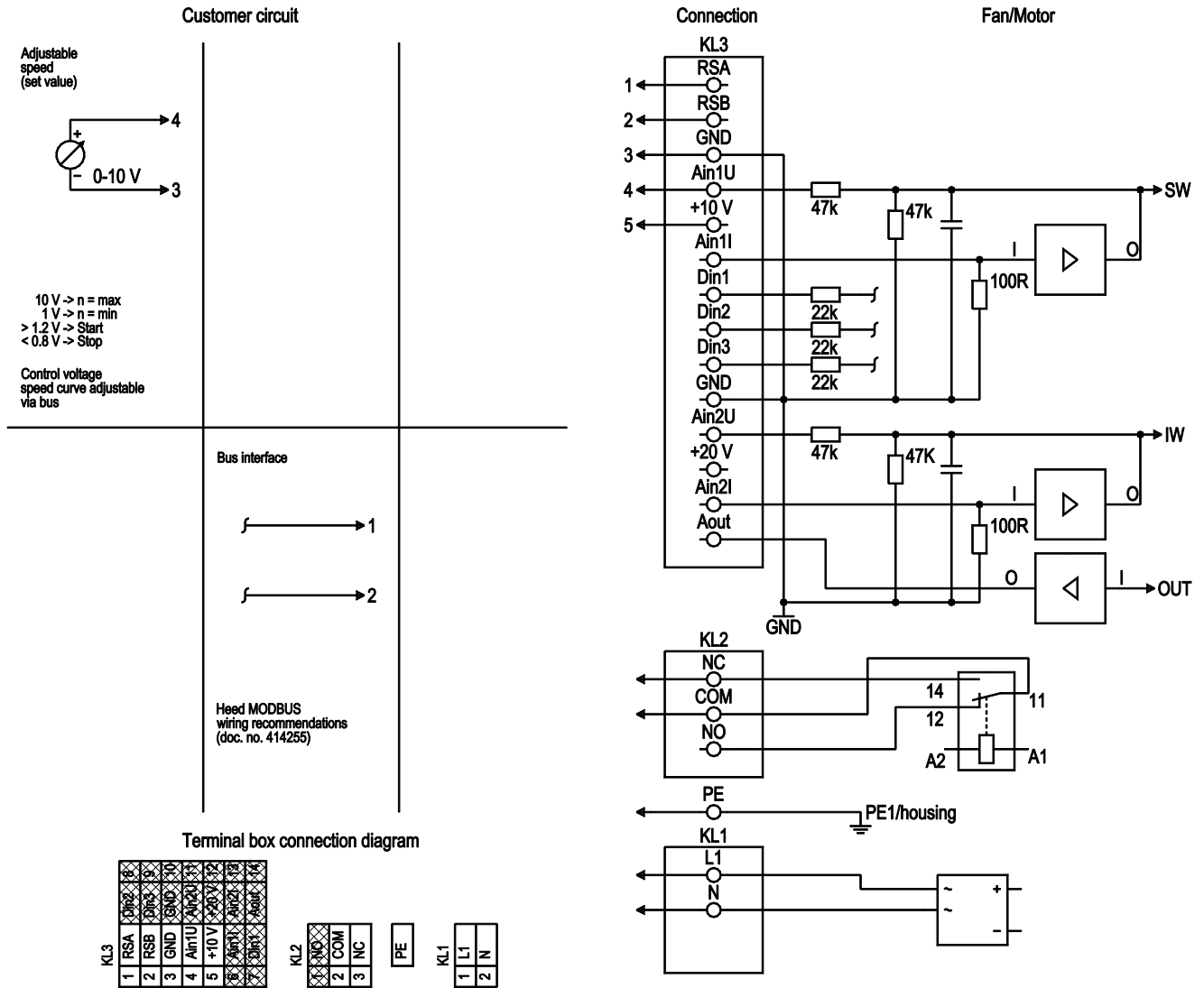

shaded gray => not brought out via leads

No.	Conn.	Designation	Function/assignment
KL1	1	L1	Supply connection, power supply; for nominal voltage range see technical data
KL1	2	N	Supply connection, power supply; for nominal voltage range see technical data
PE		PE	Ground connection, PE connection
KL2	1	NO	Status relay, floating status contact, make for failure
KL2	2	COM	Status relay, floating status contact, changeover contact, common connection, contact rating 250 VAC/ max. 2 A (AC1)/min. 10 mA
KL2	3	NC	Status relay, floating status contact, break for failure
KL3	1	RSA	Bus connection RS485, RSA, MODBUS RTU; SELV
KL3	2	RSB	Bus connection RS485, RSB, MODBUS RTU; SELV
KL3	3	GND	Reference ground for control interface; SELV
KL3	4	Ain1 U	Analog input 1, set value: 0-10 V, Ri = 100 kΩ, adjustable curve, only usable as alternative to input Ain1 I; SELV
KL3	5	+ 10 V	Fixed voltage output 10 VDC, +10 V +/- 3 %, max. 10 mA, short-circuit-proof, power supply for external devices (e.g. potentiometer); SELV



No.	Conn.	Designation	Function/assignment
KL3	6	Ain1 I	Analog input 1, set value: 4-20 mA, Ri = 100 Ω, adjustable curve, only usable as alternative to input Ain1 U; SELV
KL3	7	Din1	Digital input 1: enable electronics, enable: pin open or applied voltage 5-50 VDC disable: bridge to GND or applied voltage < 1 VDC reset function: triggers software reset after a level change to < 1 VDC; SELV
KL3	8	Din2	Digital input 2: Switching parameter sets 1/2, according to EEPROM setting, the valid or used parameter set can be selected via bus or via digital input DIN2. Parameter set 1: pin open or applied voltage 5-50 VDC Parameter set 2: bridge to GND or applied voltage < 1 VDC; SELV
KL3	9	Din3	Digital input 3: according to EEPROM setting, the integrated controller's direction of action can be selected via bus or digital input Din3; normal: pin open or applied voltage 5-50 VDC inverse: bridge to GND or applied voltage < 1 VDC; SELV
KL3	10	GND	Reference ground for control interface, SELV
KL3	11	Ain2 U	Analog input 2, measured value: 0-10 V, Ri = 100 kΩ, adjustable curve, only usable as alternative to input Ain2 I; SELV
KL3	12	+ 20 V	Fixed voltage output 20 VDC, +20 V +25/-10%, max. 50 mA, short-circuit-proof, power supply for external devices (e.g. sensors); SELV Alternatively: +24 VDC input for parameterization without line voltage
KL3	13	Ain2 I	Analog input 2, measured value: 4-20 mA, Ri = 100 Ω, adjustable curve, only usable as alternative to input Ain2 U; SELV
KL3	14	Aout	Analog output 0-10 VDC, max. 5 mA, output of current motor modulation level / motor speed adjustable curve; SELV

Curves: Air performance 50 Hz

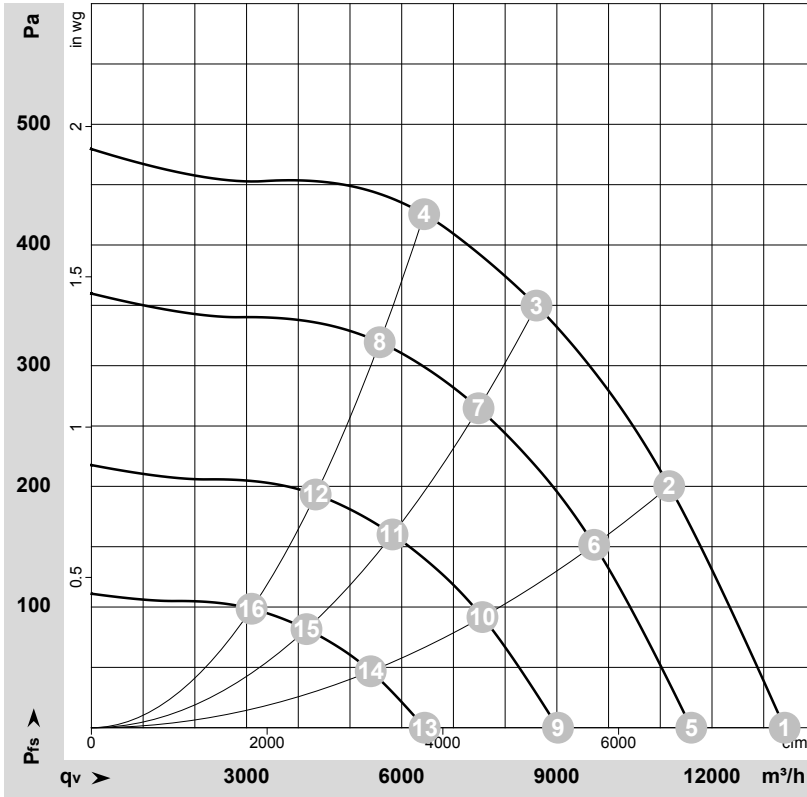

$\rho = 1.15 \text{ kg/m}^3 \pm 2 \%$

Measurement: LU-158102-1

Air performance measured according to ISO 5801 installation category A. For detailed information on the measurement setup, contact ebmpapst. Intake sound level: Sound power level according to ISO 13347 / sound pressure level measured at 1 m distance from fan axis. The values given are valid under the specified measuring conditions and may vary due to conditions of installation. For deviations from the standard configuration, the parameters have to be checked on the installed unit.

Measured values

	U	f	n	P _{ed}	I	LpA _{in}	LwA _{in}	LwA _{out}	q _v	P _{fs}	q _v	P _{fs}
	V	Hz	min ⁻¹	W	A	dB(A)	dB(A)	dB(A)	m ³ /h	Pa	cfm	in. wg
1	230	50	1030	942	4.13	76	83	87	13405	0	7890	0.00
2	230	50	1030	1295	5.67	68	75	80	11175	200	6575	0.80
3	230	50	1030	1425	6.20	64	71	76	8605	350	5065	1.41
4	230	50	1030	1399	6.11	66	72	77	6435	425	3785	1.71
5	230	50	900	610	2.67	72	79	83	11600	0	6830	0.00
6	230	50	900	853	3.73	64	71	76	9720	152	5720	0.61
7	230	50	900	931	4.07	61	68	73	7485	265	4405	1.06
8	230	50	900	909	3.97	62	69	74	5575	321	3280	1.29
9	230	50	700	287	1.26	66	73	77	9020	0	5310	0.00
10	230	50	700	401	1.76	58	65	70	7560	92	4450	0.37
11	230	50	700	438	1.91	54	61	66	5820	160	3425	0.64
12	230	50	700	428	1.87	56	63	67	4335	194	2550	0.78
13	230	50	500	105	0.46	58	64	68	6445	0	3795	0.00
14	230	50	500	146	0.64	50	56	61	5400	47	3180	0.19
15	230	50	500	160	0.70	46	53	58	4160	82	2450	0.33
16	230	50	500	156	0.68	47	54	59	3095	99	1825	0.40

U = Voltage · f = Frequency · n = Speed (rpm) · P_{ed} = Power consumption · I = Current draw · LpA_{in} = Sound pressure level intake side · LwA_{in} = Sound power level intake side
 LwA_{out} = Sound power level outlet side · q_v = Air flow · P_{fs} = Pressure increase

