

R3G630-PC17-Q1 ebmpapst Datasheet FansCo

sales@fansco.com

www.fansco.com

## Nominal data

Type	R3G630-PC17-Q1	
Motor	M3G150-NA	
Phase		3~
Nominal voltage	VAC	200
Nominal voltage range	VAC	200 .. 240
Frequency	Hz	50/60
Method of obtaining data		ml
Status		prelim.
Speed (rpm)	min <sup>-1</sup>	1580
Power consumption	W	5200
Current draw	A	15.9
Min. ambient temperature	°C	-40
Max. ambient temperature	°C	40

ml = Max. load · me = Max. efficiency · fa = Free air · cs = Customer specification · ce = Customer equipment  
Subject to change

## Data according to Commission Regulation (EU) 327/2011 (prEN 17166)

		Actual	Req. 2015			
01 Overall efficiency $\eta_{es}$	%	65.1	58.9	09 Power consumption $P_{ed}$	kW	5.11
02 Measurement category		A		09 Air flow $q_v$	m <sup>3</sup> /h	14135
03 Efficiency category		Static		09 Pressure increase $p_{fs}$	Pa	819
04 Efficiency grade N		68.2	62	10 Speed (rpm) n	min <sup>-1</sup>	1575
05 Variable speed drive		Yes		11 Specific ratio <sup>*</sup>		1.01

Data obtained at optimum efficiency level.

<sup>\*</sup> Specific ratio =  $1 + p_{fs} / 100\,000\text{ Pa}$ 

LU-207806

The efficiency values displayed for achieving conformity with the Ecodesign Regulation EU 327/2011 has been reached with defined air duct components (e.g. inlet rings).  
The dimensions must be requested from ebm-papst. If other air conduction geometries are used on the installation side, the ebm-papst evaluation loses its validity/the conformity must be confirmed again.  
The product does not fall within the scope of Regulation (EU) 2019/1781 due to the exception specified in Article 2 (2a) (motors completely integrated into a product).



## Technical description

Weight	37 kg
Size	630 mm
Motor size	150
Rotor surface	Painted black
Electronics housing material	Die-cast aluminum
Impeller material	Sheet aluminum
Number of blades	5
Direction of rotation	Clockwise, viewed toward rotor
Degree of protection	IP55
Insulation class	"F"
Moisture (F) / Environmental (H) protection class	H1
Ambient temperature note	Occasional start-up at temperatures between -40°C and -25°C is permitted. For continuous operation at ambient temperatures below -25°C (such as refrigeration applications), use must be made of a fan design with special low-temperature bearings.
Max. permitted ambient temp. for motor (transport/storage)	+80 °C
Min. permitted ambient temp. for motor (transport/storage)	-40 °C
Installation position	Shaft horizontal or rotor on bottom; rotor on top on request
Condensation drainage holes	On rotor side
Mode	S1
Motor bearing	Ball bearing
Technical features	<ul style="list-style-type: none"> <li>- Operation and alarm display with LED</li> <li>- External 15-50 VDC input (parameterization)</li> <li>- Alarm relay</li> <li>- Integrated PI controller</li> <li>- Configurable inputs/outputs (I/O)</li> <li>- MODBUS V6.4</li> <li>- Motor current limitation</li> <li>- RS-485 MODBUS-RTU</li> <li>- Soft start</li> <li>- Voltage output 3.3-24 VDC, Pmax = 800 mW</li> <li>- Control interface with SELV potential safely disconnected from the mains</li> <li>- Thermal overload protection for electronics/motor</li> <li>- Line undervoltage / phase failure detection</li> <li>- Vibration sensor</li> </ul>
Touch current according to IEC 60990 (measuring circuit Fig. 4, TN system)	<= 3.5 mA
Electrical hookup	Terminal box
Motor protection	Electronic motor protection
Protection class assignment	I; If a protective earth is connected by the customer This component for installation may have several local protection classes. This information relates to this component's basic design. The final protection class is based on the component's intended installation and connection.
Conformity with standards	EN 61800-5-1; CE
Approval	CSA C22.2 No. 77 + CAN/CSA-E60730-1; UL 1004-7 + 60730-1; EAC

Product drawing

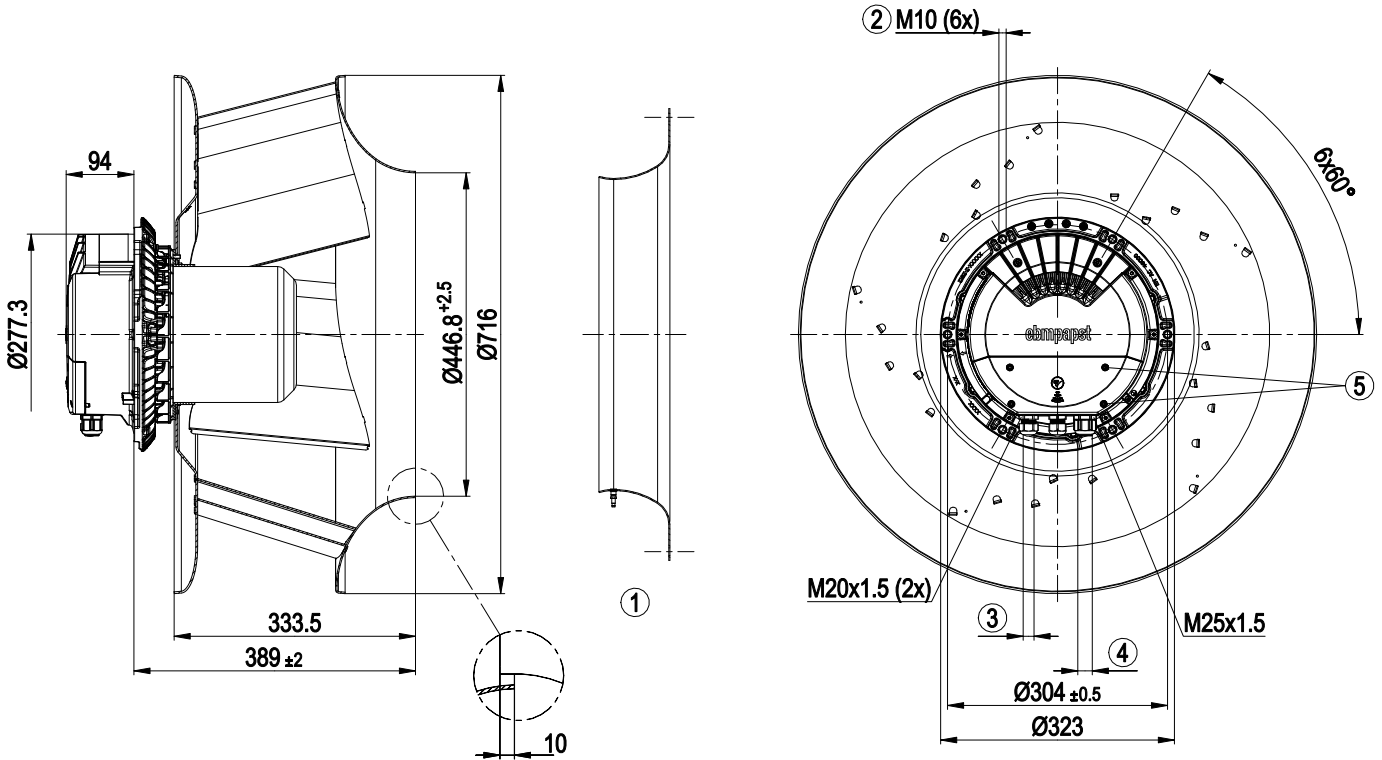

1	Accessory part: Inlet ring 64040-2-4013 with pressure tap (k-factor 438) not included in scope of delivery
2	Max. clearance for screw 20 mm
3	Cable diameter min. 4 mm, max. 10 mm, tightening torque $4 \pm 0.6$ Nm
4	Cable diameter min. 5 mm, max. 14 mm, tightening torque $6 \pm 0.9$ Nm
	(The tightening torque is designed for PVC cables. If the cable materials are different, the tightening torque may have to be adjusted)
5	Tightening torque $3 \pm 0.3$ Nm

## Accessory part

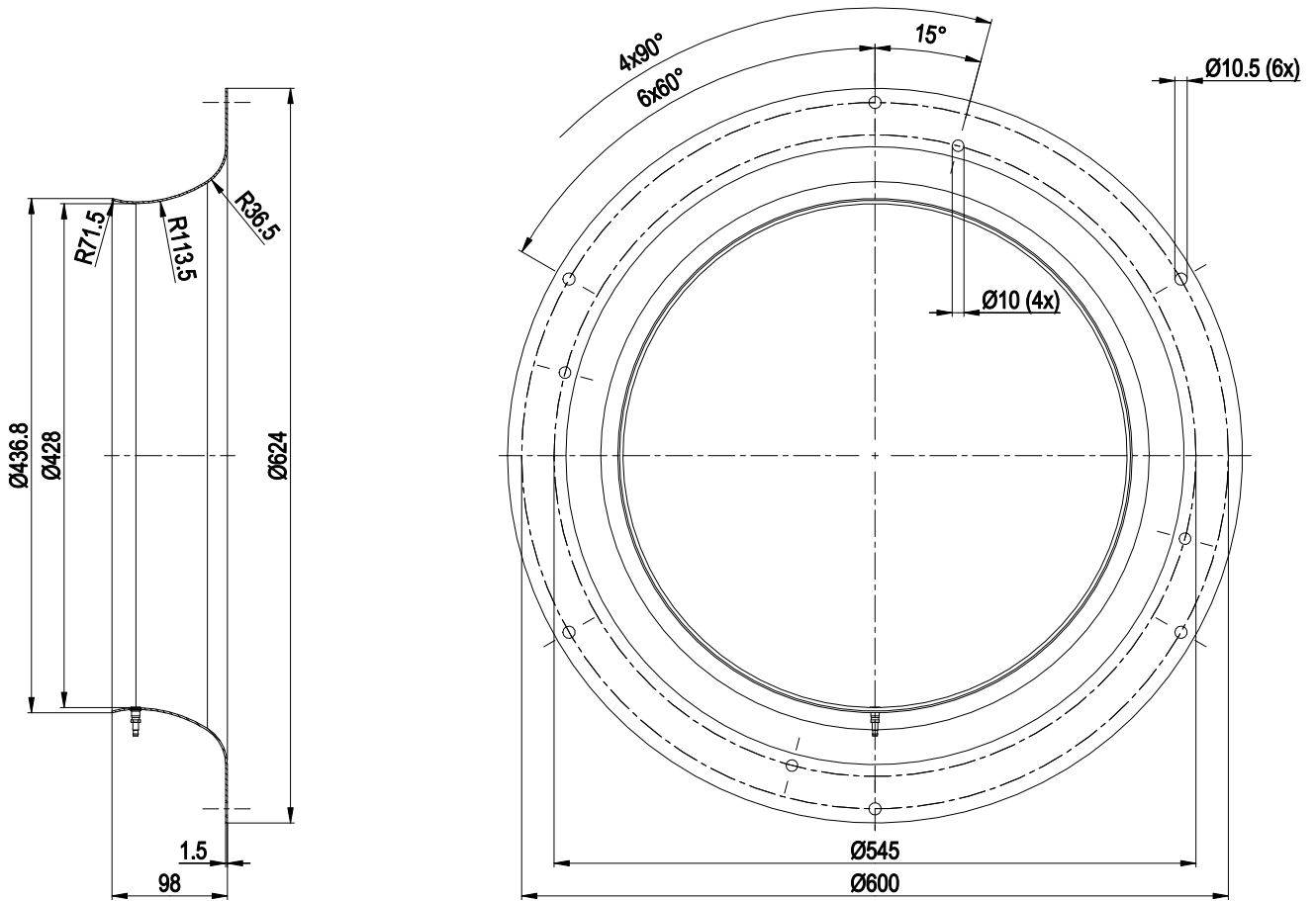

Inlet ring 64040-2-4013 with pressure tap (k-factor 438)

## Connection diagram

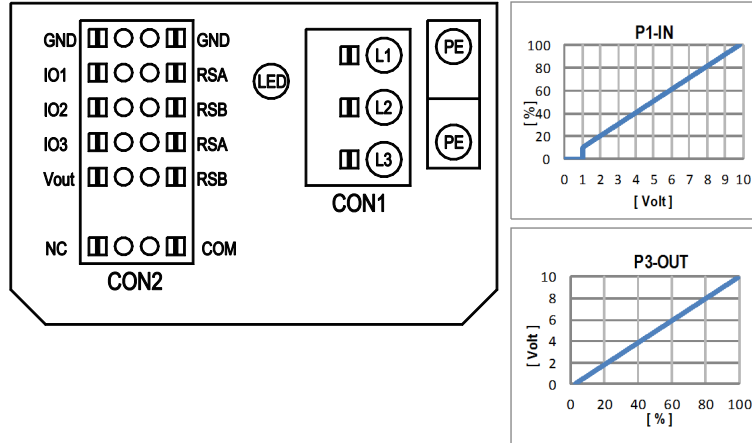

No.	Conn.	Designation	Function/assignment
	CON1	L1, L2, L3	Power supply, phase, see nameplate for voltage range
	PE	PE	Protective earth
	CON2	RSA	RS485 interface for MODBUS, RSA; SELV
	CON2	RSB	RS485 interface for MODBUS, RSB; SELV
	CON2	GND	Reference ground for control interface, SELV
	CON2	IO1	Function parameterizable (see "Optional interface functions" table) Factory setting: Digital input - high active, function: Disable input, SELV - inactive: Pin open or applied voltage < 1.5 VDC - active: applied voltage 3.5-50 VDC Reset function: Triggering of error reset on change of state from "enabled" to "disabled"
	CON2	IO2	Function parameterizable (see "Optional interface functions" table) Factory setting: Analog input 0-10 V / PWM, Ri=100 kΩ, function: Set value Characteristic curve parameterizable (see input characteristic curve P1-IN), SELV
	CON2	IO3	Function parameterizable (see "Optional interface functions" table) Factory setting: Analog output 0-10 V, max. 5 mA, function: Fan modulation level Characteristic curve parameterizable (see output characteristic curve P3-OUT), SELV
	CON2	Vout	Voltage output 3.3-24 VDC ±5%, Pmax=800 mW, voltage parameterizable Factory setting: 10 VDC short-circuit-proof, supply for external devices, SELV alternatively: 15-50 VDC input for parameterization via MODBUS without line voltage
	CON2	COM	Status relay, floating status contact, common connection, contact rating 250 VAC / 2 A (AC1) / min. 10 mA, reinforced insulation on supply side and on control interface side
	CON2	NC	Status relay, floating status contact, break for failure
		LED	green: status = good, ready for operation orange: status = warning red: status = failure
		P1-IN	Input characteristic curve
		P3-OUT	Output characteristic curve

## Terminal/plug assignment

CON2	configurable IO mode	electrical specification	configurable IO functions: normal / inverse	INPUT		OUTPUT													
				source: set value	source: sensor value	switch: parameter set: #1 / #2	switch: control function: heating (pos.) / cooling (neg.)	switch: direction of rotation: cw / ccw	switch: set value source	switch: fan enable / disable	signal: tach out	signal: diagnostics out	signal: fan modulation level %	signal: actual speed	signal: system modulation level %	signal: remote control output 0-10V	pulse input for auto-addressing	pulse output for auto-addressing	
IO1	○ Din1 (active high): digital input	active: applied voltage 3.5-50VDC, SELV not active: pin open or applied voltage < 1.5VDC	configurable IO functions: normal / inverse  MODBUS Register for IO mode configuration	D158 [0]	○	○	○	○	○	○	○	○	○	○	○	○	○	○	
	○ Ain1 0-10V/PWM: analog input	RI = 100k, characteristic curve parameterizable, f <sub>PWM</sub> = 1k..10kHz, SELV		D158 [2]	○	○	○	○	○	○	○	○	○	○	○	○	○	○	○
	○ Tach out (open collector output)	U <sub>max</sub> = 50VDC, I <sub>max</sub> = 20mA, SELV		D158 [5]	○	○	○	○	○	○	○	○	○	○	○	○	○	○	○
	○ Diagnostics out (open collector output)	U <sub>max</sub> = 50VDC, I <sub>max</sub> = 20mA, SELV		D158 [6]	○	○	○	○	○	○	○	○	○	○	○	○	○	○	○
	○ Din2 (active high): digital input	active: applied voltage 3.5-50VDC, SELV not active: pin open or applied voltage < 1.5VDC		D159 [0]	○	○	○	○	○	○	○	○	○	○	○	○	○	○	○
	○ Ain2 0-10V/PWM: analog input	RI = 100k, characteristic curve parameterizable, f <sub>PWM</sub> = 1k..10kHz, SELV		D159 [2]	○	○	○	○	○	○	○	○	○	○	○	○	○	○	○
IO2	○ Ain2 4-20mA: analog input	RI = 125R, characteristic curve parameterizable, SELV	D159 [3]	○	○	○	○	○	○	○	○	○	○	○	○	○	○	○	
	○ Din3 (active high): digital input	active: applied voltage 3.5-50VDC, SELV not active: pin open or applied voltage < 1.5VDC	D15A [0]	○	○	○	○	○	○	○	○	○	○	○	○	○	○	○	
	○ Din3 (active low): digital input	active: applied voltage < 1.5VDC, SELV not active: pin open or applied voltage 3.5-50VDC	D15A [1]	○	○	○	○	○	○	○	○	○	○	○	○	○	○	○	
	○ PWMIn3: digital input idle level high	PWM = 40Hz - 10kHz, characteristics parameterizable	D15A [7]	○	○	○	○	○	○	○	○	○	○	○	○	○	○	○	
IO3	○ PWMIn3: digital input idle level low	active: pin open or applied voltage 3.5-50VDC not active: applied voltage < 1.5VDC, SELV	D15A [8]	○	○	○	○	○	○	○	○	○	○	○	○	○	○	○	
	○ Aout3 0-10V: analog output	function parameterizable, max. 5mA max output frequency 300Hz, SELV	D15A [4]	○	○	○	○	○	○	○	○	○	○	○	○	○	○	○	
	○ Tacho out (pulses), analog output	0-10V max. 5mA max output frequency 300Hz, SELV	D15A [5]	○	○	○	○	○	○	○	○	○	○	○	○	○	○	○	
RSA	RSB	MODBUS bus connection,	MODBUS RTU, specification V6.4, SELV	D15A [6]	○	○	○	○	○	○	○	○	○	○	○	○	○	○	
				D16E [..]	○	○	○	○	○	○	○	○	○	○	○	○	○	○	○
Vout	alternatively: Input auxiliary power supply for parameterization via RS485/MODBUS RTU without line voltage	voltage output	voltage parameterizable 3.3...24VDC +/- 5%, P <sub>max</sub> =800mW, short-circuit-proof, supply for external devices, SELV	D16E [..]	○	○	○	○	○	○	○	○	○	○	○	○	○	○	
		15...50VDC																	

○ configurable option

For further information and additional functions see EC Control Software: Fan-Set-App. or MODBUS Parameter Specification V6.4



## Curves: Air performance 50 Hz

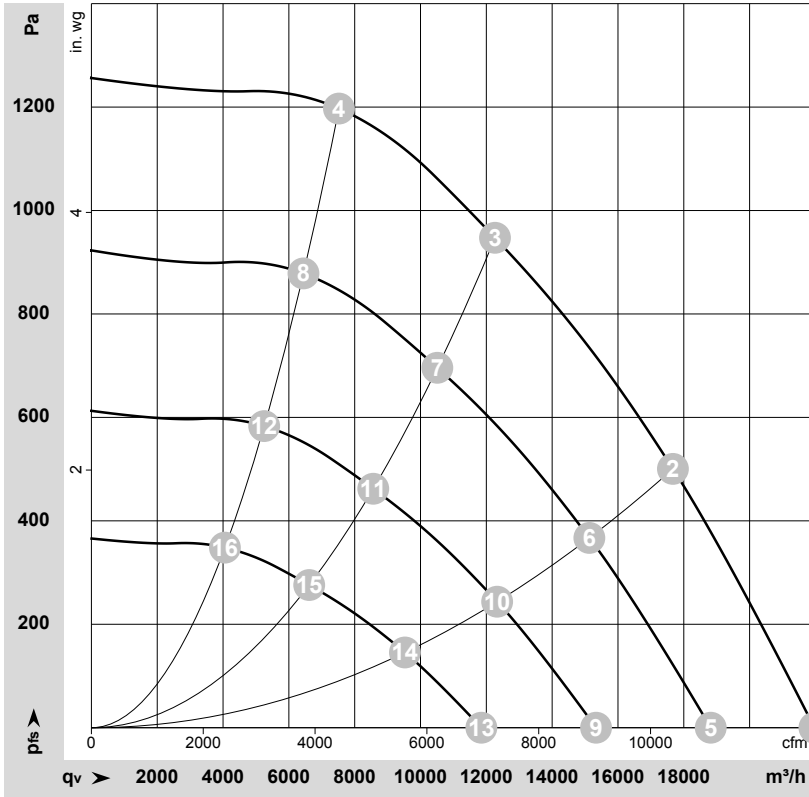

$\rho = 1.15 \text{ kg/m}^3 \pm 2 \%$

Measurement: LU-207806-1

Air performance measured according to ISO 5801 installation category A. For detailed information on the measurement setup, contact ebmpapst. Intake sound level: Sound power level according to ISO 13347 / sound pressure level measured at 1 m distance from fan axis. The values given are valid under the specified measuring conditions and may vary due to conditions of installation. For deviations from the standard configuration, the parameters have to be checked on the installed unit.

## Measured values

	Wired	U	f	n	P <sub>ed</sub>	I	LpA <sub>in</sub>	LwA <sub>in</sub>	LwA <sub>out</sub>	q <sub>v</sub>	P <sub>fs</sub>	q <sub>v</sub>	P <sub>fs</sub>
		V	Hz	min <sup>-1</sup>	W	A	dB(A)	dB(A)	dB(A)	m <sup>3</sup> /h	Pa	cfm	in. wg
1	3~	200	50	1580	2673	8.31	86	93	95	21970	0	12930	0.00
2	3~	200	50	1580	4335	13.25	78	86	90	17670	500	10400	2.01
3	3~	200	50	1580	5200	15.90	75	83	88	12265	950	7220	3.81
4	3~	200	50	1580	4733	14.44	80	88	92	7520	1200	4425	4.82
5	3~	200	50	1350	1680	5.22	82	89	91	18820	0	11075	0.00
6	3~	200	50	1350	2722	8.32	74	82	86	15130	367	8905	1.47
7	3~	200	50	1350	3274	9.97	72	79	84	10510	696	6185	2.79
8	3~	200	50	1350	2975	9.07	76	84	88	6445	879	3790	3.53
9	3~	200	50	1100	909	2.83	77	84	86	15335	0	9025	0.00
10	3~	200	50	1100	1472	4.50	69	77	81	12330	244	7255	0.98
11	3~	200	50	1100	1771	5.39	66	74	79	8565	462	5040	1.85
12	3~	200	50	1100	1609	4.91	71	79	83	5250	583	3090	2.34
13	3~	200	50	850	419	1.30	70	77	79	11850	0	6975	0.00
14	3~	200	50	850	679	2.08	63	70	74	9525	145	5605	0.58
15	3~	200	50	850	817	2.49	60	67	72	6620	276	3895	1.11
16	3~	200	50	850	743	2.26	65	73	77	4055	348	2390	1.40

Wired = Wiring · U = Voltage · f = Frequency · n = Speed (rpm) · P<sub>ed</sub> = Power consumption · I = Current draw · LpA<sub>in</sub> = Sound pressure level intake side · LwA<sub>in</sub> = Sound power level intake side · LwA<sub>out</sub> = Sound power level outlet side · q<sub>v</sub> = Air flow · P<sub>fs</sub> = Pressure increase

